

**Unified
Development
Ordinance**

Village of Montgomery

**Adopted on
March 8, 2021
(Ordinance 1903)**

Amended on October 11, 2021 per Ordinance 1929



TABLE OF CONTENTS

SECTION 1: TITLE AND APPLICABILITY6

- 1.01 Title 6
- 1.02 Authority and Purpose 6
- 1.03 Applicability..... 6
- 1.04 Transition Rules..... 7
- 1.05 Interpretation..... 8
- 1.06 Enforcement 8
- 1.07 Severability..... 9
- 1.08 Effective Date..... 9

SECTION 2: ADMINISTRATIVE BODIES AND PROCEDURES10

- 2.01 Purpose 10
- 2.02 Village Board 10
- 2.03 Planning and Zoning Commission 10
- 2.04 Zoning Officer..... 11
- 2.05 Application Procedure 12
- 2.06 Notice..... 13
- 2.07 Public Hearing 14

SECTION 3: ANNEXATION AND SUBDIVISION APPLICATION APPROVAL PROCEDURES16

- 3.01 Purpose 16
- 3.02 Annexation Applications 16
- 3.03 Subdivision Applications 17

SECTION 4: ZONING APPLICATION APPROVAL PROCEDURES22

- 4.01 Purpose 22
- 4.02 Site Plan Review 22
- 4.03 Special Use Permit 24
- 4.04 Variation..... 26
- 4.05 Administrative Adjustment..... 28
- 4.06 Text or Map Amendment..... 31
- 4.07 Appeal 33
- 4.08 Floodplain Development Permit..... 34
- 4.09 Sign Permit 34

4.10 Temporary Use Permit	35
SECTION 5: PLANNED UNIT DEVELOPMENTS	37
5.01 Purpose	37
5.02 Applicability.....	37
5.03 Procedure.....	38
5.04 Amendment to Approved Planned Unit Developments.....	41
5.05 Standards for Planned Unit Developments	41
5.06 Provision of Community Amenities	42
5.07 Expiration of Approved Planned Unit Developments.....	43
SECTION 6: NONCONFORMITIES	44
6.01 Purpose	44
6.02 Applicability.....	44
6.03 Nonconforming Uses	44
6.04 Nonconforming Structures	45
6.05 Nonconforming Lots of Record.....	47
6.06 Nonconforming Site Elements	47
SECTION 7: SUBDIVISION DEVELOPMENT STANDARDS	49
7.01 General Provisions	49
7.02 Subdivision Design and Layout	50
7.03 Conservation and Cluster Subdivision Design.....	52
7.04 Street Standards	55
7.05 Required Public Improvements	64
7.06 Cash and Land Donations.....	68
SECTION 8: ZONING DISTRICT REGULATIONS	74
8.01 Purpose	74
8.02 Applicability.....	74
8.03 Development Standards of General Applicability.....	74
8.04 Zoning Map	75
8.05 Use of Land and Buildings.....	75
8.06 Establishment of Zoning Districts and Purpose Statements.....	77
8.07 Summary Table of Zoning Requirements.....	79
8.08 FO Floodplain Overlay District	80

8.09 A Agricultural District	82
8.10 Design Requirements for Residential Zoning Districts.....	84
8.11 R-1 Single-Unit Dwelling District	88
8.12 R-2 Single-Unit Dwelling District	90
8.13 R-3 Single-Unit Dwelling District	92
8.14 R-4 Attached Single-Unit Dwelling District	94
8.15 R-5 Multiple-Unit Dwelling District	96
8.16 Design Requirements for Business Zoning Districts.....	98
8.17 MD Mill District	100
8.18 B-1 Neighborhood Business District	102
8.19 B-2 Regional Business District	104
8.20 Design Requirements for Manufacturing Zoning Districts	106
8.21 M-1 Light Manufacturing District.....	108
8.22 M-2 General Manufacturing District.....	110
SECTION 9: USES	112
9.01 General Provisions	112
9.02 Principal Uses and Structures	113
9.03 Accessory Uses and Structures	123
9.04 Temporary Uses and Structures.....	135
9.05 Environmental Performance Standards.....	138
SECTION 10: OFF-STREET PARKING AND LOADING	140
10.01 General Provisions	140
10.02 Off-Street Parking Spaces	141
10.03 Bicycle Parking	147
10.04 Parking Design Standards	149
10.05 Pedestrian Circulation Systems.....	152
10.06 Driveways.....	153
10.07 Vehicular Stacking Requirements	157
10.08 Recreational Vehicle Parking	159
10.09 Off-Street Loading Facility Requirements.....	159
SECTION 11: LANDSCAPE STANDARDS	161
11.01 General Provisions	161
11.02 Tree Preservation.....	162

11.03 Design, Installation, and Maintenance	164
11.04 Street Trees.....	167
11.05 Parking Lot Landscaping.....	168
11.06 Buffer Yards.....	172
11.07 Screening Requirements.....	174
11.08 Landscaped Setbacks	176
11.09 Outdoor Lighting	177
SECTION 12: SIGNS.....	179
12.01 Purpose	179
12.02 General Construction and Design Standards.....	179
12.03 Sign Measurement Standards.....	181
12.04 Master Sign Plan	182
12.05 Permanent Signs	183
12.06 Temporary Signs	201
12.07 Prohibited Signs	203
SECTION 13: DEFINITIONS	204
13.01 Purpose	204
13.02 Definition of Terms	204

SECTION 1: TITLE AND APPLICABILITY

[1.01 Title](#)

[1.02 Authority and Purpose](#)

[1.03 Applicability](#)

[1.04 Transition Rules](#)

[1.05 Interpretation](#)

[1.06 Enforcement](#)

[1.07 Severability](#)

[1.08 Effective Date](#)

1.01 Title

This zoning ordinance shall serve as the official zoning ordinance of the Village of Montgomery and shall be known by, referred to, and cited as the "Village of Montgomery Unified Development Ordinance," or "Ordinance."

1.02 Authority and Purpose

The provisions of this Ordinance are adopted pursuant to the authority granted to the Village by the Illinois Municipal Code. The purposes of this Ordinance are many, but foremost among these purposes are to:

- A. Protect and promote the health, safety, comfort, convenience, and general welfare of the public.
- B. Ensure adequate light, air, open space, privacy, and access to property.
- C. Implement the goals and objectives of the Village's Comprehensive Plan and the other land use policies of the Village.
- D. Maintain and promote orderly land use patterns and development.
- E. Facilitate the provision of adequate public services and infrastructure.
- F. Protect the Village's quality of life and the character of its neighborhoods by ensuring that development is compatible and cohesive.
- G. Protect and enhance the taxable value of land, buildings, and structures.
- H. Promote development that sustainably manages environmentally sensitive issues.
- I. Define the responsibilities of the Village's administrative bodies and establish procedures for the effective use of the provisions of this Ordinance.

1.03 Applicability

- A. Jurisdiction. This Ordinance applies to all land, uses, and structures within the corporate limits of the Village of Montgomery.

- B. **General Applicability.** The provisions of this Ordinance are interpreted and applied as the minimum requirements for the protection and promotion of the health, safety, comfort, convenience, and general welfare of the public to achieve the purposes for which this Ordinance was adopted.
- C. **General Prohibition.** No structure, use of any structure or land, or lot of record or zoning lot may be established, enlarged, extended, altered, moved, divided, or maintained in any manner contrary to the provisions of this Ordinance.
- D. **Private Agreements.** This Ordinance is not intended to nullify any easement, covenant, or other private agreement. In cases where this Ordinance is more restrictive than a private agreement, this Ordinance controls. The Village is not required to enforce any private agreements.
- E. **Other Laws and Regulations.** Unless specifically stated, this Ordinance controls over less restrictive ordinances, regulations, and statutes, while more restrictive ordinances, regulations, and statutes control over the provisions of this Ordinance. The more restrictive provision is the provision that imposes more stringent controls.

1.04 Transition Rules

The following transition rules apply in determining the applicability of this Ordinance with respect to the previously applicable regulations.

- A. **Existing Illegal Uses, Structures, and Lots.** Any use, structure, or lot that was established illegally as of the effective date of this Ordinance, or its subsequent amendments, remains illegal if it does not conform with the requirements of this Ordinance.
- B. **Permitted Uses Rendered Special Uses.** If a use was classified as a permitted use prior to the effective date of this Ordinance, and is classified as a special use as of the effective date of this Ordinance, or its subsequent amendments, that use is deemed a lawful special use. Any subsequent addition, enlargement, or expansion of that use must conform to this Ordinance's requirements for special uses.
- C. **Special Uses Rendered Permitted Uses.** If a use was classified as a special use prior to the effective date of this Ordinance, and is classified as a permitted use as of the effective date of this Ordinance, or its subsequent amendments, that use is deemed a lawful permitted use. Any subsequent addition, enlargement, or expansion of that use must conform to this Ordinance's requirements for such permitted use and is no longer subject to the special use ordinance under which it was originally approved.
- D. **Uses Rendered Legally Nonconforming.** If a use was classified as a permitted or special use prior to the effective date of this Ordinance, and this Ordinance no longer classifies that use as either a permitted or special use in the zoning district in which it is located, that use is deemed a legal nonconforming use and is controlled by the provisions of [Section 6 \(Nonconformities\)](#).
- E. **Structures and Lots Rendered Legally Nonconforming.** If a structure or lot existing on the effective date of this Ordinance was conforming or legally nonconforming prior to the effective date of this Ordinance, and such structure or lot does not meet all standards set forth in this Ordinance, that structure or lot is deemed legally nonconforming and is controlled by the provisions of [Section 6 \(Nonconformities\)](#).

- F. Previously Issued Building Permits. If a building permit for a building or structure was lawfully issued prior to the effective date of this Ordinance, and if construction has begun within three months after the issuance of that permit and diligently pursued to completion, the structure may be completed based on the previously issued building permit, and may be occupied under an occupancy permit for the use originally intended upon completion. If the use was classified as a permitted or special use prior to the effective date of this Ordinance, and this Ordinance no longer classifies that use as either a permitted or special use in the zoning district in which it is located, that use is deemed a legal nonconforming use and is controlled by the provisions of [Section 6 \(Nonconformities\)](#).
- G. Previously Granted Special Uses and Variations. All special uses and variations granted prior to the effective date of this Ordinance remain in effect. The recipient of the special use or variation may proceed to develop the property in accordance with the plans and any applicable conditions approved by the Village Board. If the recipient has failed to act on the special use or variation before the approval expires, including any periods of extension granted, the provisions of this Ordinance govern.

1.05 Interpretation

- A. Graphics, Tables, and Text. The graphics, tables, and text in this Ordinance are regulatory. The graphics in this Ordinance are representations of the standards of this Ordinance and are not intended to represent every circumstance which may arise in the Village. In case of a conflict, text controls over tables and graphics, and tables control over graphics.
- B. Tense and Form. Words used in the present tense include the past and future tenses.
- C. Number. The singular number includes the plural number, and vice versa.
- D. Abbreviations. "N/A" is an abbreviation of "not applicable," "ft" is an abbreviation of "feet," and "sf" is an abbreviation of "square feet."
- E. Undefined Terms. Any words not defined in this Ordinance can be interpreted as defined in normal dictionary usage.
- F. Lists. Lists of examples prefaced with "including the following," "such as," or similar phrases are not exclusive, and do not preclude the Zoning Officer from interpreting the list to include similar, unspecified examples.
- G. Computation of Time. References to "days" are to calendar days. The time in which an act is to be completed is computed by excluding the first day and including the last day. If the last day is a Saturday, Sunday or holiday observed by the Village, that day is excluded. A day concludes at the close of business of Village Hall and any materials received after that time will be considered to have been received the following day.

1.06 Enforcement

- A. Enforcement. This Ordinance is enforced by the Zoning Officer. The Zoning Officer may seek the assistance of the Village Attorney to enjoin, abate, or stop any violation of this Ordinance. The Zoning Officer may seek the assistance of the Police Department to enforce this Ordinance. The property

owner charged with a violation of this Ordinance may be held responsible for any legal expenses incurred by the Village.

- B. Penalties and Fines. Any person, firm, corporation, or organization of any kind who does not comply with any of the provisions of this Ordinance, or who resists its enforcement, will be fined \$50 to \$500 for each violation. Each day that a violation exists or continues constitutes a separate offense with a separate fee. The accumulation of penalties for violations stops upon correction of the violation, but the obligation to pay for violations already committed does not.

1.07 Severability

If any portion of this Ordinance is adjudged by any court of competent jurisdiction to be invalid, that judgment does not nullify the validity of the remainder of this Ordinance. The effect of the judgment will be confined to the portion of the Ordinance immediately involved in the judgment rendered. If any court of competent jurisdiction decides that the application of any provision of this Ordinance is invalid as it pertains to a particular lot, structure, building, or use, the effect of the judgment is confined to such lot, structure, building, or use.

1.08 Effective Date

The effective date of this Ordinance is the date of its adoption, March 8, 2021.

SECTION 2: ADMINISTRATIVE BODIES AND PROCEDURES

[2.01 Purpose](#)

[2.02 Village Board](#)

[2.03 Planning and Zoning Commission](#)

[2.04 Zoning Officer](#)

[2.05 Application Procedure](#)

[2.06 Notice](#)

[2.07 Public Hearing](#)

2.01 Purpose

The purpose of this Section is to establish the specific duties and responsibilities of the Village Board, Planning and Zoning Commission, and Zoning Officer as they relate to this Ordinance, and establish the application, notice, and public hearing procedures for the applications and approvals of this Ordinance.

2.02 Village Board

The Village Board has the following specific duties and responsibilities pursuant to this Ordinance.

- A. Make final decisions on applications for annexations, refer to [Section 3.02 \(Annexation Application\)](#)
- B. Make final decisions on applications for preliminary and final plats, refer to [Section 3.03 \(Subdivision Applications\)](#).
- C. Make final decisions on applications for special use permits, refer to [Section 4.03 \(Special Use Permit\)](#).
- D. Make final decisions on applications for variations, refer to [Section 4.04 \(Variation\)](#).
- E. Make final decisions on applications for text and zoning map amendments, refer to [Section 4.06 \(Text or Zoning Map Amendment\)](#).
- F. Make final decisions on applications for planned unit developments, refer to [Section 5 \(Planned Unit Developments\)](#).
- G. Make final decisions on the Village's comprehensive plan and proposed amendments to the adopted comprehensive plan.
- H. Other responsibilities as designated by this Ordinance or by law.

2.03 Planning and Zoning Commission

The Planning and Zoning Commission has the following specific duties and responsibilities pursuant to this Ordinance.

- A. Make recommendations to the Village Board on applications for annexations, refer to [Section 3.02 \(Annexation Application\)](#).

- B. Make recommendations to the Village Board on applications for preliminary plats of subdivision, refer to [Section 3.03 \(Subdivision Application\)](#).
- C. Make recommendations to the Village Board on applications for special use permits, refer to [Section 4.03 \(Special Use Permit\)](#).
- D. Make recommendations to the Village Board on applications for variations, refer to [Section 4.04 \(Variation\)](#).
- E. Make recommendations to the Village Board on applications for text and zoning map amendments, refer to [Section 4.06 \(Text or Zoning Map Amendment\)](#).
- F. Make final decisions on applications for appeals, refer to [Section 4.07 \(Appeals\)](#).
- G. Make recommendations to the Village Board on applications for planned unit developments, refer to [Section 5 \(Planned Unit Developments\)](#).
- H. Prepare and recommend a comprehensive plan to the Village Board and propose amendments to the plan from time to time.
- I. Other responsibilities as designated by this Ordinance or by the Village Board.

2.04 Zoning Officer

The Director of Community Development is considered the Zoning Officer and has the following duties and responsibilities pursuant to this Ordinance. For the purposes of this Ordinance, the term Zoning Officer is inclusive of any designees.

- A. Review and make final decisions on applications for minor subdivisions, refer to [Section 3.03.E.1 \(Minor Subdivision\)](#).
- B. Review and make final decisions on applications for site plan review, refer to [Section 4.02 \(Site Plan Review\)](#).
- C. Review and make final decisions on applications for administrative adjustments, refer to [Section 4.05 \(Administrative Adjustment\)](#).
- D. Review and make final decisions on applications for floodplain development permits, refer to [Section 4.08 \(Floodplain Development Permit\)](#).
- E. Review and make final decisions on applications for sign permits, refer to [Section 4.09 \(Sign Permit\)](#).
- F. Review and make final decisions on applications for temporary use permits, refer to [Section 4.10 \(Temporary Use Permit\)](#).
- G. Review and forward applications for annexations, refer to [Section 3.02 \(Annexation Applications\)](#); preliminary and final plats, refer to [Section 3.03 \(Subdivision Application\)](#); special use permits, refer to [Section 4.03 \(Special Use Permit\)](#); variations, refer to [Section 4.04 \(Variation\)](#); text and zoning map amendments, refer to [Section 4.06 \(Text or Zoning Map Amendment\)](#); appeals, refer to [Section 4.07](#)

[\(Appeal\)](#); planned unit developments, refer to [Section 5.0 \(Planned Unit Developments\)](#); and other administrative reviews required by this Ordinance to the Planning and Zoning Commission or Village Board, as specified.

- H. Maintain and make available permanent and current records of this Ordinance and the Zoning Map.
- I. Maintain and make available permanent and current records as required by this Ordinance including, but not limited to, all relevant information and official action regarding zoning applications.
- J. Other responsibilities as designated by this Ordinance, the Village Board, or the Planning and Zoning Commission.

2.05 Application Procedure

- A. Authorization. Any property owner in the Village, or property proposed for location within the Village in the case of annexation applications, or individual expressly identified by any property owner in writing, is authorized to file an application for annexation, subdivision, floodplain development permit, site plan review, special use permit, variation, administrative adjustment, text amendment, zoning map amendment, appeal, Ordinance interpretation, sign permit, or temporary use permit.
- B. Pre-Application Consultation. Prior to filing an application, the applicant may arrange a pre-application consultation with the Zoning Officer to discuss the application. At the pre-application consultation, the Zoning Officer provides the applicant with guidance on the application procedure and the evaluation of applications.
- C. Filing. All applications must be filed with the Zoning Officer on forms provided by the Village. Applications must be filed in such number as requested by the Village, with plans at a scale sufficient to allow a clear understanding of the proposal, and with all of the contents required by the application, as determined by the Zoning Officer.
- D. Fees. Every application must be accompanied by the required filing fee as established and modified from time to time by the Village Code. Until the fee is paid, no steps will be taken to process the application. Applications initiated by the Village are exempt from fees.
- E. Completeness. The Zoning Officer determines whether the application is complete. Upon determining that the application is complete, the Zoning Officer notifies the applicant and the application is scheduled for consideration by the appropriate board, commission, or official. Upon determining that the application is deficient, the Zoning Officer notifies the applicant and no steps are taken to process the application until the deficiencies are rectified. An application is not considered on-file until the Zoning Officer determines the application is complete.
- F. Failure to Act. The Zoning Officer or Planning and Zoning Commission's failure to issue a decision or make a recommendation on any application within the applicable period specified in this Ordinance is deemed approval of, or a recommendation for approval of, such application. The Village Board's failure to issue a decision on any application within the applicable period specified in this Ordinance is deemed denial of such application.
- G. Supermajority Vote. A two-thirds favorable vote of the Village Trustees is required to approve any application for which the Planning and Zoning Commission recommends denial.

- H. **Withdrawal of Application.** An applicant has the right to withdraw an application at any time prior to the decision on the application by a board, commission, or official. Application fees for withdrawn applications will not be refunded.
- I. **Successive Application.** A successive application for an application that has been denied will not be reviewed or heard within one year after the date of denial, except if substantial new information has become known since the denial. A successive application filed within one year of the date of denial must include detailed information that justifies its consideration. The Zoning Officer determines whether a successive application is appropriate for submittal.
- J. **Public Examination of Application.** Any person may examine any application and any of the application’s supporting materials, subject to the Illinois Freedom of Information Act. Upon reasonable request, any person is entitled to copies of the application and related documents.

2.06 Notice

The administrative body conducting a hearing or making a decision will not hear or review an application unless the applicant complies with the notice requirements of this Section. [Table 2.06.1 Types of Required Notice](#) indicates the types of notice required prior to public hearings or decisions on each of the applications.

Table 2.06.1 Types of Required Notice

Application	Notice Type		
	Published	Mailed/Delivered	Posted Sign
Annexation 3.02	●	●	
Preliminary Plat of Subdivision 3.03.F.2	●	●	●
Special Use Permit 4.03	●	●	●
Variation 4.04	●	●	●
Administrative Adjustment 4.05		●	
Text Amendment 4.06	●		
Zoning Map Amendment 4.06	●	●	●
Appeal 4.07	●		
Planned Unit Development Section 5	●	●	●

A. **Published Notice.**

1. **Applicability.** Published notice of a public hearing is provided by the Village.
2. **Time Frame.**
 - a. **Newspaper.** Published notice must be provided in a newspaper of general circulation within the Village 15 to 30 days in advance of the scheduled hearing date.
 - b. **Internet.** The Village may provide additional published notice of the hearing on the Village’s website at least 48 hours in advance of the scheduled hearing date.
3. **Contents.** The notice must include the date, time, location, and purpose of the hearing, the name of the body holding the hearing, the name of the applicant, and the address of the subject property.

B. Mailed or Delivered Notice.

1. Annexations, Preliminary Plats of Subdivision, Special Use Permits, Variations, Zoning Map Amendments, and Planned Unit Developments.
 - a. Time Frame. The notice must be provided 15 to 30 days in advance of the scheduled hearing date.
 - b. Notice to Neighboring Properties. Mailed or delivered notice must be provided by the applicant to the owners of all properties located within 250 feet of the property line of the subject property. The area occupied by any public right-of-way is not included as part of this requirement. The applicant must provide notice via registered mail with return receipt requested to every property within 250 feet of the subject property. The requirements of this Section do not prevent the applicant from providing additional notice to properties located more than 250 feet from the property line of the subject property as the applicant may deem appropriate.
 - c. Contents. The notice must include the date, time, location, and purpose of the hearing, the name of the body holding the hearing, the name of the applicant, and the address of the subject property.
2. Administrative Adjustments.
 - a. Time Frame. The notice must be provided at least 15 days prior to the date that the Zoning Officer indicates that a decision will be rendered on the application.
 - b. Notice to Neighboring Properties. Mailed or delivered notice must be provided by the Village to the owners of all properties located adjacent to and across the street from the subject property. Mailed or delivered notice of Zoning Officer review must be provided by the Village for applications for administrative adjustments. The Zoning Officer must prepare an affidavit stating that notice was provided to each property that states the names, addresses, and property identification numbers of all notice recipients.

C. Posted Sign Notice.

1. Applicability. Posted sign notice of a public hearing must be provided by the Village.
2. Time Frame. The notice must be provided 15 to 30 days in advance of the scheduled hearing date.
3. Location. Posted sign notice must be located on the property so that it is legible to passersby. A minimum of one sign must be provided per street frontage.
4. Contents. The notice must include the date, time, location, and purpose of the hearing, the name of the body holding the hearing, the name of the applicant, and the address of the subject property.
5. Requirement Modifications. The Zoning Officer may modify the posted sign notice requirements when these requirements are found to be inappropriate or ineffective in providing the intended notice. Modifications to the posted sign notice may include content, quantity, and location.

2.07 Public Hearing

- A. Call for Public Hearings. All public hearings are held at the call of the chairperson of the hearing body and are open to the public.

- B. Testimony. Any person who attends a public hearing may appear and present testimony regarding an application. All testimony must be given under oath or by affirmation.
- C. Voting. The hearing body must keep minutes of its proceedings that show the vote of each member of the hearing body upon each application, or if absent, or failing to vote, indicating that fact.
- D. Meetings and Records. The hearing body must keep records of its hearings, and evaluation standards must be included in the minutes of each application specifying the reasons for the hearing body's decision. Every determination of the hearing body must be part of the public record.
- E. Rules of Procedure. The hearing body's rules of procedure must not conflict with this Ordinance or with state statutes.

SECTION 3: ANNEXATION AND SUBDIVISION APPLICATION APPROVAL PROCEDURES

[3.01 Purpose](#)

[3.02 Annexation Application](#)

[3.03 Subdivision Application](#)

3.01 Purpose

The purpose of this Section is to establish the applicability, procedures, requirements, and approval standards for the Village's annexation and subdivision applications.

3.02 Annexation Applications

- A. Purpose. The purpose of this application is to provide a procedure for annexation of unincorporated land to the Village of Montgomery. It is specifically intended to establish standards to manage the fiscal impacts of annexation, enhance the character of Village neighborhoods, and strengthen Montgomery's economic resources.
- B. Procedure. See [Figure 3.02.1 Annexation Application Procedure](#).

Figure 3.02.1 Annexation Application Procedure



1. Action by the Zoning Officer
 - a. An application for annexation, including an annexation agreement, must be filed with the Zoning Officer in accordance with [Section 2.05 \(Application Procedure\)](#).
 - b. Upon the Zoning Officer's determination that the application is complete, the Zoning Officer must prepare a report for the Planning and Zoning Commission based upon each of the standards of [Section 3.02.C \(Standards for Annexations\)](#), and schedule the application for consideration by the Planning and Zoning Commission.
2. Action by the Planning and Zoning Commission
 - a. The Planning and Zoning Commission must conduct a public hearing on the application in accordance with [Section 2.07 \(Public Hearing\)](#) within 60 days after receipt of a complete application, including an annexation agreement. The 60-day period may be extended with the written consent of the applicant.
 - b. The Planning and Zoning Commission must evaluate the application based upon the Zoning Officer's report, the evidence presented at the public hearing, and each of the standards of [Section 3.02.C \(Standards for Annexations\)](#).
 - c. The Planning and Zoning Commission must recommend approval or denial of the application. In recommending approval, the Planning and Zoning Commission may:
 - 1) Recommend conditions upon the establishment, location, construction, maintenance, and operation of the annexation as deemed necessary to protect the public interest.
 - 2) Recommend guarantees from the applicant to assure compliance with the conditions of approval.

- d. The Planning and Zoning Commission must forward its recommendation to the Village Board within 30 days after the close of the public hearing.
- 3. Action by the Village Board
 - a. The Village Board must consider the application within 60 days after receiving the recommendation of the Planning and Zoning Commission, including an annexation agreement. The 60-day period may be extended with the written consent of the applicant.
 - b. The Village Board must evaluate the application based upon the Zoning Officer's report, the recommendation of the Planning and Zoning Commission, the evidence presented at the public hearing, and each of the standards of [Section 3.02.C \(Standards for Annexations\)](#).
 - c. The Village Board must take action in the form of approval, denial, or referral of the application back to the Planning and Zoning Commission for further consideration.
 - d. A two-thirds favorable vote of the Village Board is required to approve the application if the Planning and Zoning Commission recommends denial of the application.
 - 4. Annexed Land Classification. Any property annexed to the Village must be classified R-1 Single-Unit Dwelling District upon annexation and must be subject to the requirements of the R-1 District until the property is rezoned, unless the property is designated otherwise as part of an annexation agreement.
- C. Standards for Annexations. The Village Board, Planning and Zoning Commission, and Zoning Officer must evaluate applications for annexations with specific written findings based on each of the standards of this Section.
- 1. The proposed annexation is in compliance with state law.
 - 2. The parcels proposed for annexation are contiguous to parcels located in the Village.
 - 3. The annexation conforms to all annexation or service extension policies of the Village.
 - 4. Proposed public infrastructure and utilities are provided to the satisfaction of the Village Engineer, including water facilities, wastewater facilities, drainage facilities, streets, and transportation facilities.
 - 5. The proposed annexation supports any planned capital improvement policy.
 - 6. The annexation supports the land use, development intensity, and planned pace of growth in the Village as indicated in the Comprehensive Plan and the other land use policies of the Village.

3.03 Subdivision Applications

- A. Purpose. The purpose of this application is to provide a procedure for the subdivision or resubdivision of a lot into two or more lots, the consolidation of two or more lots, or a change in the boundary of one or more lots.
- B. Applicability. An applicant must comply with these regulations in order to divide, consolidate, or alter the boundaries of a lot within the Village or within its extraterritorial jurisdiction. The Village will not grant any permits for the improvement or occupancy of any lot until the requirements of this Section have been met, the subdivision application has been approved, the final plat has been recorded with

the Kane and/or Kendall County Recorder of Deeds, and a copy of the recorded subdivision has been deposited with the Village.

- C. Subdivision Development Standards. All subdivisions must comply with the development standards established in [Section 7 \(Subdivision Development Standards\)](#) and [Section 8 \(Zoning District Regulations\)](#).
- D. Subdivision Classification. Subdivisions are classified as either minor subdivisions approved by the Zoning Officer, or major subdivisions approved by the Village Board. Applications for minor subdivisions and major subdivisions must be filed with the Zoning Officer in accordance with [Section 2.05 \(Application Procedure\)](#).
 - 1. Minor Subdivision. A minor subdivision involves any of the following:
 - a. The division of a single lot into three or fewer lots which front on an existing right-of-way that is not a state or county highway, is served by existing utilities, does not require the dedication of land for public rights-of-way, parks, or other public purposes, does not require any other public improvements, and does not require any exceptions or variances from this Ordinance.
 - b. The consolidation of, or change in the boundary between, three or fewer adjoining lots.
 - 2. Major Subdivision. A major subdivision involves any of the following:
 - a. The division of a single lot into four or more lots.
 - b. Any division or consolidation that involves the construction of new rights-of-way, access to a state or county highway, the extension of utilities, the dedication of land for public rights-of-way, parks, or other public purposes, requires any other improvements, or requires exceptions or variations from this Ordinance.
 - c. The consolidation of, or change in the boundary between, four or more adjoining lots.
 - d. Any division or consolidation that involves conservation and cluster subdivision design in accordance with the standards of [Section 7.03 \(Conservation and Cluster Subdivision Design\)](#).
- E. Minor Subdivision Procedure. Approval of a minor subdivision requires a pre-application consultation, preliminary plat approval, and final plat approval. See [Figure 3.03.1 Minor Subdivision Application Procedure](#).

Figure 3.03.1 Minor Subdivision Application Procedure



- 1. Pre-Application Consultation. The required pre-application consultation allows the applicant to receive advice and assistance from the Zoning Officer and appropriate Village staff prior to preparing the required preliminary plat.
 - a. The applicant must provide a required sketch plan of the proposed subdivision showing the layout of lots and other features in relation to existing conditions.
 - b. During the pre-application consultation, the Zoning Officer will determine if the proposed subdivision is exempt from any items required in the preliminary plat submittal.

2. Approval of Preliminary and Final Plats. The required preliminary plat and final plat allow the applicant to obtain final minor subdivision application approval from the Zoning Officer.
 3. Action by the Zoning Officer.
 - a. Upon determining that the application is complete, the Zoning Officer must evaluate the application pursuant to the standards of [Section 7 \(Subdivision Development Standards\)](#) and [Section 8.00 \(Zoning District Regulations\)](#). The Zoning Officer may consult with other staff during the evaluation process.
 - b. The Zoning Officer must prepare a report and render a decision within 30 days after receipt of a complete application and take action in the form of approval or denial of the application.
 - c. If a preliminary plat is approved, the applicant may prepare a final plat and submit it to the Zoning Officer for review and approval.
 - d. If the preliminary plat is denied, the applicant may appeal the decision to the Planning and Zoning Commission within 30 days after the date of the decision in accordance with [4.07 \(Zoning Appeal\)](#).
 - e. Following final plat approval by the Zoning Officer, the Zoning Officer may sign the approved final plat.
 4. Recording of the Final Plat. The final plat must be recorded within 90 days after Village Board approval of the final plat. The applicant may request an extension of time in writing if such extension is agreed to by the Zoning Officer. The plat approval will expire if the final plat is not recorded in such timeframe, including any agreed upon extensions of time.
 - a. The Village will record the final plat with the Kane and/or Kendall County Recorder of Deeds. One copy of the recorded final plat must be retained by the Village.
 - b. A building permit will not be issued for the subject property until the final plat has been recorded and a copy has been retained by the Village.
- F. Major Subdivision Procedure. Approval of a major subdivision requires a pre-application consultation, preliminary plat approval, and final plat approval. [See Figure 3.03.2 Major Subdivision Application Procedure.](#)

Figure 3.03.2 Major Subdivision Application Procedure



1. Pre-Application Consultation. The required pre-application consultation allows the applicant to receive advice and assistance from the Zoning Officer and appropriate Village staff prior to preparing the required preliminary plat.
 - a. The applicant must provide a required sketch plan of the proposed subdivision showing the layout of lots, stormwater detention areas, and other features in relation to existing conditions.
 - b. During the pre-application consultation, the Zoning Officer will determine if the proposed subdivision is exempt from any items required in the preliminary plat submittal.
2. Preliminary Plat Approval. The required preliminary plat allows the applicant to obtain final approval of the preliminary plat from the Planning and Zoning Commission and the Village Board. The application must include a traffic study prepared by a professional engineer that indicates the

traffic impact of the proposed development, except when exempted from this requirement by the Zoning Officer.

a. Action by the Zoning Officer.

- (1) Upon determining that the application is complete, the Zoning Officer must evaluate the application pursuant to the standards of [Section 7 \(Subdivision Development Standards\)](#) and [Section 8 \(Zoning District Regulations\)](#). The Zoning Officer may consult with other Village staff and local district representatives during the evaluation process.
- (2) The Zoning Officer must prepare a report for the Planning and Zoning Commission based upon the standards of this Ordinance and schedule the application for consideration by the Planning and Zoning Commission.

b. Action by the Planning and Zoning Commission.

- (1) The Planning and Zoning Commission must conduct a public hearing on a proposed preliminary plat at a meeting in accordance with [Section 2.07 \(Public Hearing\)](#) within 60 days after receipt of a complete application. The 60-day period may be extended with the written consent of the applicant.
- (2) The Planning and Zoning Commission must recommend approval or denial of the application.
- (3) The Planning and Zoning Commission must forward its recommendation to the Village Board within 30 days after the close of the public hearing.

c. Action by the Village Board.

- (1) The Village Board must consider the application at a meeting within 60 days after receiving the recommendation of the Planning and Zoning Commission. The 60-day period may be extended with the written consent of the applicant.
- (2) The Village Board must take action in the form of approval or denial of the application.
 - (a) If a preliminary plat is approved, the applicant may prepare a final plat and submit it to the Zoning Officer for review. After the Zoning Officer determines that the submitted final plat is consistent with the approved preliminary plat, the application may proceed to the Village Board for approval as a final plat.
 - (b) If a preliminary plat is denied, the Village Board must state the reason for the denial.

3. Final Plat Approval. The required final plat allows the applicant to obtain approval of the final plat from the Village Board.

a. Action by the Zoning Officer.

- (1) The Zoning Officer must review the submitted final plat and determine whether the application is complete and that the submitted final plat is consistent with the approved preliminary plat.
- (2) Upon acceptance of a complete application consistent with the approved preliminary plat, the Zoning Officer must prepare a report for the Village Board based upon the standards of this Ordinance and schedule the application for consideration by the Village Board.

b. Action by Village Board.

- (1) The Village Board must consider the application at a meeting within 60 days after receiving the report of the Zoning Officer. The 60-day period may be extended with the written consent of the applicant.
- (2) The Village Board must take action in the form of approval or denial of the application.

c. Recording of the Final Plat. The final plat must be recorded within 90 days after Village Board approval of the final plat. The applicant may request an extension of time in writing if such extension is agreed to by the Zoning Officer. The plat approval will expire if the final plat is not recorded in such timeframe, including any agreed upon extensions of time.

- (1) The Village must record the final plat with the Kane and/or Kendall County Recorder of Deeds. One copy of the recorded final plat will be retained by the Village.
 - (2) A building permit must not be issued for the subject property until the final plat has been recorded, a copy has been retained by the Village, and construction security has been established per [Section 7.05.C \(Construction Security\)](#).
- d. Expiration of Preliminary and Final Plat Approval.
- (1) Expiration of Preliminary Plat Approval. Preliminary plat approval will expire and be revoked if an application for approval of a final plat has not been filed within one year after approval of the preliminary plat.
 - (2) Expiration of Final Plat Approval. Final plat approval will expire and be revoked if construction of subdivision improvements has not begun within two years of final plat approval.
 - (3) Extension of Approval. The applicant may extend the expiration period for an approved preliminary or final plat by means of a written request filed with the Zoning Officer at least 30 days prior to the expiration of the period. The Zoning Officer must decide whether to grant or deny the applicant's request within 15 days of receipt of the applicant's written request.
- G. Illegal Recording. A subdivision must not be not recorded until it has been approved in accordance with these regulations. A subdivision that is recorded without approval is invalid. The Village will nullify the illegal recording and have it stricken from county records. The Village is authorized to prosecute the parties responsible for the illegal recording in addition to all other remedies available to the Village at law or in equity.

SECTION 4: ZONING APPLICATION APPROVAL PROCEDURES

[4.01 Purpose](#)

[4.02 Site Plan Review](#)

[4.03 Special Use Permit](#)

[4.04 Variation](#)

[4.05 Administrative Adjustment](#)

[4.06 Text or Map Amendment](#)

[4.07 Appeal](#)

[4.08 Floodplain Development Permit](#)

[4.09 Sign Permit](#)

[4.10 Temporary Use Permit](#)

4.01 Purpose

The purpose of this Section is to establish the applicability, procedures, requirements, and approval standards for each of the Village’s zoning applications.

4.02 Site Plan Review

- A. Purpose. The purpose of this site plan review application is to ensure development and redevelopment that is harmonious with surrounding properties, and consistent with the intent of the Comprehensive Plan and this Ordinance.
- B. Applicability. Approval of a site plan review application is required for the following:
1. New construction of a principal structure or use in any zoning district.
 2. An addition to a building in any zoning district that increases the gross floor area of the building by ten percent.
 3. New construction of an accessory dwelling unit in any zoning district.
 4. New construction, expansion, reconstruction, or reduction of an off street parking lot, tandem parking facility, shared parking facility, or any loading facility.
- C. Procedure. See [Figure 4.02.1 Site Plan Review Application Procedure](#).

Figure 4.02.1 Site Plan Review Application Procedure

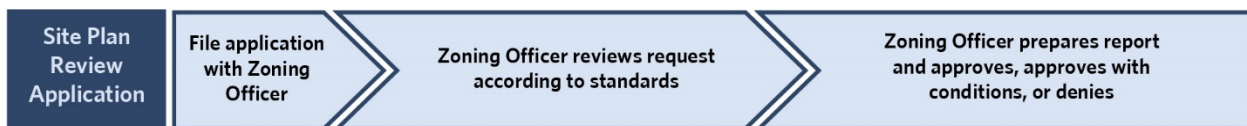

1. Action by the Zoning Officer
 - a. An application for site plan review must be filed with the Zoning Officer in accordance with [Section 2.05 \(Application Procedures\)](#).
 - b. Upon determining that the application is complete, the Zoning Officer must evaluate the application based upon each of the standards of [Section 4.02.D \(Standards for Site Plan](#)

[Review](#)). The Zoning Officer may consult with other Village staff and local district representatives during the evaluation process.

- c. The Zoning Officer must prepare a report and take action in the form of approval, approval with conditions, or denial of the application within 60 days after receipt of a complete application.

D. Standards for Site Plan Review. The Zoning Officer must evaluate applications for site plan review with specific written findings based on each of the standards of this Section.

1. The site plan for the proposed development is consistent with the existing character and zoning of adjacent properties and other property within the immediate vicinity of the proposed development.
2. The site plan for the proposed development will not adversely impact adjacent properties and other properties within the immediate vicinity of the proposed development.
3. The site plan for the proposed development will be provided with adequate utilities, access roads, parking, loading, drainage, stormwater flow paths, exterior lighting, and/or other necessary facilities.
4. The site plan for the proposed development is designed to preserve the environmental resources of the zoning lot.
5. The site plan must accommodate on-site pedestrian circulation from parking areas, plazas, open space, and public rights-of-way. Pedestrian and vehicular circulation must be separated to the greatest extent possible.
6. The site plan must locate curb cuts for safe and efficient ingress and egress of vehicles. The use of shared curb cuts and cross-access easements must be provided when appropriate.
7. The site plan for the proposed development includes architectural design that contributes positively to the Village's aesthetic appearance.
8. The site plan for the proposed development is consistent with the intent of the Comprehensive Plan, this Ordinance, and the other land use policies of the Village.

E. Amendment to Approved Site Plan. Any change to an approved site plan that minimally affects the essential design, composition, and character of the site plan may be considered a minor amendment. The Zoning Officer must make a decision on a request for a minor amendment in accordance with [Section 4.02.D \(Standards for Site Plan Review\)](#) or determine that any received application must be resubmitted for a new site plan review in accordance with [Section 4.02 \(Site Plan Review\)](#). Minor amendments must include the following:

1. Any change in gross floor area of the development by less than five percent.
2. Any change in the building height of the development by less than five percent.

3. Any change in the proportion of the impervious coverage of the development by less than five percentage points
 4. Any change in the location of dimensions of walkways, driveways, streets, parking facilities, and loading facilities within the development by less than five feet.
 5. Any change in the number of off-street parking spaces provided within the development by less than 10 percent.
- F. Expiration of Site Plan Approval. Site plan approval will expire and be revoked if either of the following conditions occur.
1. A building permit has not been obtained within one year after approval of the site plan. The applicant may request one six-month extension of this period by means of a written request filed no later than 30 days prior to the expiration of the one-year period. The Zoning Officer must decide whether to grant or deny the applicant’s request within 15 days of receipt of the applicant’s written request.
 2. The standards of this Ordinance or any of the terms and conditions of the site plan approval are violated.

4.03 Special Use Permit

- A. Purpose. The purpose of this special use application is to provide for uses which may have a special, unique, or unusual impact upon the use of neighboring property.
- B. No Presumption of Approval. A use established as a special use in [Section 9.0 \(Uses\)](#) does not constitute a presumption that an application for such special use will be approved. Each proposed special use must be evaluated on an individual basis with regard to the applicable standards of this Ordinance to determine whether approval of the special use is appropriate at the particular location in the manner proposed.
- C. Expansion or Alteration. Any addition, enlargement, or expansion of a use holding a special use permit must require a new special use permit.
- D. Procedure. See [Figure 4.03.1 Special Use Permit Application Procedure](#).

Figure 4.03.1 Special Use Permit Application Procedure



1. Action by the Zoning Officer
 - a. An application for a special use permit must be filed with the Zoning Officer in accordance with [Section 2.05 \(Application Procedures\)](#).
 - b. Upon determining that the application is complete, the Zoning Officer must prepare a report for the Planning and Zoning Commission based upon the standards of [Section 4.03.E \(Standards for Special Use Permits\)](#), and schedule the application for consideration by the Planning and

Zoning Commission. The Zoning Officer may consult with other Village staff and local district representatives during the evaluation process.

2. Action by the Planning and Zoning Commission

- a. The Planning and Zoning Commission must conduct a public hearing on the application in accordance with [Section 2.07 \(Public Hearing\)](#) within 60 days after receipt of a complete application. The 60-day period may be extended with the written consent of the applicant.
- b. The Planning and Zoning Commission must evaluate the application based upon the Zoning Officer's report, the evidence presented at the public hearing, and each of the standards of [Section 4.03.E \(Standards for Special Use Permits\)](#).
- c. The Planning and Zoning Commission must recommend approval, approval with conditions, or denial of the application. In recommending approval, the Planning and Zoning Commission may:
 - (1) Recommend conditions upon the establishment, location, construction, maintenance, and operation of the special use as deemed necessary to protect the public interest.
 - (2) Recommend guarantees from the permittee as deemed necessary to assure compliance with the stipulated conditions of approval.
- d. The Planning and Zoning Commission must forward its recommendation to the Village Board within 30 days after the close of the public hearing.

3. Action by the Village Board

- a. The Village Board must consider the application within 60 days after receiving the recommendation of the Planning and Zoning Commission. The 60-day period may be extended with the written consent of the applicant.
- b. The Village Board must evaluate the application based upon the Zoning Officer's report, the recommendation of the Planning and Zoning Commission, the evidence presented at the public hearing, and each of the standards of [Section 4.03.E \(Standards for Special Use Permits\)](#).
- c. The Village Board must take action in the form of approval, approval with conditions, denial, or referral of the application back to the Planning and Zoning Commission for further consideration. In approving a special use permit, the Village Board may:
 - (1) Require conditions upon the establishment, location, construction, maintenance, and operation of the special use as deemed necessary to protect the public interest.
 - (2) Require guarantees from the permittee as deemed necessary to assure compliance with the stipulated conditions of approval.
- d. A two-thirds favorable vote of the Village Trustees is required to approve the application if the Planning and Zoning Commission recommends denial of the application.

E. Standards for Special Use Permits. The Village Board, Planning and Zoning Commission, and Zoning Officer must evaluate applications for special use permits with specific written findings based on each of the standards of this Section.

1. The proposed special use will not endanger the health, safety, comfort, convenience and general welfare of the public.
2. The proposed special use is compatible with the character of adjacent properties and other property within the immediate vicinity of the proposed special use.

3. The proposed special use will not impede the normal and orderly development and improvement of adjacent properties and other property within the immediate vicinity of the proposed special use.
 4. The proposed special use will not require utilities, access roads, drainage and/or other facilities or services to a degree disproportionate to that normally expected of permitted uses in the district, nor generate disproportionate demand for new services or facilities in such a way as to place undue burdens upon existing development in the area.
 5. The proposed special use is consistent with the intent of the Comprehensive Plan, this Ordinance, and the other land use policies of the Village.
- F. Expiration of Special Use Permit Approval. Special use permit approval will expire and be revoked if any of the following conditions occur.
1. The use has not commenced or a building permit has not been obtained within one year after approval of the special use permit. The applicant may request one extension of this period for up to one additional year by means of a written request filed at least 30 days prior to the expiration of the initial one-year period. The Zoning Officer must decide whether to grant or deny the applicant’s request within 15 days of receipt of the applicant’s written request.
 2. The licenses or permits required for the operation or maintenance of the use are not obtained or are subsequently terminated.
 3. The standards of this Ordinance or any of the terms and conditions of the special use permit are violated.
 4. The operation of the use for which a special use permit has been issued ceases for a period of six consecutive months.

4.04 Variation

- A. Purpose. The purpose of this variation application is to grant relief from the regulations of this Ordinance to the extent that literal enforcement of such regulations creates particular hardships or practical difficulties in developing property due to the unique attributes of the property. The purpose of the variation process is not to provide relief from the use permissions of this Ordinance.
- B. Applicability. Any application for relief from the regulations of this Ordinance that is not established as an administrative adjustment in [Section 4.05 \(Administrative Adjustment\)](#) must be considered a variation.
- C. Procedure. See [Figure 4.04.1 Variation Application Procedure](#).

Figure 4.04.1 Variation Application Procedure



1. Action by the Zoning Officer
 - a. An application for a variation must be filed with the Zoning Officer in accordance with [Section 2.05 \(Application Procedures\)](#).
 - b. Upon determining that the application is complete, the Zoning Officer must prepare a report for the Planning and Zoning Commission based upon each of the standards of [Section 4.04.D \(Standards for Variations\)](#), and schedule the application for consideration by the Planning and Zoning Commission. The Zoning Officer may consult with other Village staff and local district representatives during the evaluation process.

2. Action by the Planning and Zoning Commission
 - a. The Planning and Zoning Commission must conduct a public hearing on the application in accordance with [Section 2.07 \(Public Hearing\)](#) within 60 days after receipt of a complete application. The 60-day period may be extended with the written consent of the applicant.
 - b. The Planning and Zoning Commission must evaluate the application based upon the Zoning Officer's report, the evidence presented at the public hearing, and each of the standards of [Section 4.04.D \(Standards for Variations\)](#).
 - c. The Planning and Zoning Commission must recommend approval, approval with conditions, or denial of the application. In recommending approval, the Planning and Zoning Commission may:
 - (1) Recommend conditions upon the establishment, location, construction, maintenance, and operation of the property that receives a variation as deemed necessary to protect the public interest.
 - (2) Recommend approval of a variation from the regulations of this Ordinance less than that requested by the applicant, if the Planning and Zoning Commission finds that the applicant is entitled to some relief, but not to the entire relief requested, based upon each of the standards of [Section 4.04.D \(Standards for Variations\)](#).
 - (3) Recommend guarantees from the permittee as deemed necessary to assure compliance with the stipulated conditions of approval.
 - d. The Planning and Zoning Commission must forward its recommendation to the Village Board within 30 days after the close of the public hearing.

3. Action by the Village Board
 - a. The Village Board must consider the application within 60 days after receiving the recommendation of the Community Development Commission. The 60-day period may be extended with the written consent of the applicant.
 - b. The Village Board must evaluate the application based upon the Zoning Officer's report, the recommendation of the Community Development Commission, the evidence presented at the public hearing, and each of the standards of [Section 4.04.D \(Standards for Variations\)](#).
 - c. The Village Board must take action in the form of approval, approval with conditions, denial, or referral of the application back to the Planning and Zoning Commission for further consideration. In approving a variation, the Village Board may:
 - (1) Impose conditions upon the establishment, location, construction, maintenance, and operation of the property that receives a variation as deemed necessary to protect the public interest.
 - (2) Grant a variation from the regulations of this Ordinance less than that requested by the applicant, if the Village Board finds that the applicant is entitled to some relief, but not to the entire relief requested, based upon each of the standards of [Section 4.05.D \(Standards for Variations\)](#).

- (3) Require guarantees from the permittee as deemed necessary to assure compliance with the stipulated conditions of approval.
 - d. A two-thirds favorable vote of the Village Trustees is required to approve the application if the Planning and Zoning Commission recommends denial of the application.
- D. Standards for Variations. The Village Board, Planning and Zoning Commission, and Zoning Officer must evaluate applications for variations with specific written findings based on each of the standards of this Section.
1. The proposed variation will not endanger the health, safety, comfort, convenience, and general welfare of the public.
 2. The proposed variation is compatible with the character of adjacent properties and other property within the immediate vicinity of the proposed variation.
 3. The proposed variation alleviates an undue hardship created by the literal enforcement of this Ordinance.
 4. The proposed variation is necessary due to the unique physical attributes of the subject property, which were not deliberately created by the applicant.
 5. The proposed variation represents the minimum deviation from the regulations of this Ordinance necessary to accomplish the desired improvement of the subject property.
 6. The proposed variation is consistent with the intent of the Comprehensive Plan, this Ordinance, and the other land use policies of the Village.
- E. Transferability. Variation approval runs with the land and is not affected by changes of ownership, tenancy, or management.
- F. Expiration of Variation Approval. Variation approval will expire and be revoked if any of the following conditions occur.
1. A building permit has not been obtained within one year after approval of the variation. The applicant may request one six-month extension of this period by means of a written request filed at least 30 days prior to the expiration of the initial six-month period. The Zoning Officer must decide whether to grant or deny the applicant's request within 15 days of receipt of the applicant's written request.
 2. The standards of this Ordinance or any of the terms and conditions of the variation are violated.

4.05 Administrative Adjustment

- A. Purpose. The purpose of this administrative adjustment application is to allow development that deviates from the specific regulations of this Ordinance within a narrowly defined set of circumstances to the extent that literal enforcement of such regulations creates particular hardships or practical difficulties in developing property due to the unique attributes of the property.

B. Applicability. Any application to allow development that deviates from the specific regulations of this Ordinance established in this Section is considered an administrative adjustment.

1. A reduction of the minimum required lot area up to 5 percent.
2. A reduction of the minimum required lot width up to 5 percent.
3. An increase in the maximum permitted impervious coverage by five percentage points or less.
4. A reduction of the minimum required front setback up to 10 percent.
5. An increase in the maximum permitted front setback up to 10 percent.
6. A reduction of the minimum required corner side setback up to 10 percent.
7. An increase in the maximum permitted corner side setback up to 10 percent.
8. A reduction of the minimum required interior side setback up to 10 percent.
9. A reduction of the minimum required rear setback up to 10 percent.
10. A reduction of the minimum required street frontage up to 5 percentage points.
11. A reduction of the minimum required off-street parking up to 5 percent, or four spaces, whichever is higher.
12. A reduction of the required runoff infiltration for parking lot landscape areas up to 50 percent.
13. An increase in the maximum permitted sign area up to 5 percent.
14. An increase in the maximum permitted sign height up to 5 percent.
15. Any change to the standards for temporary signs with permit requirements as established in [Section 12.06 \(Temporary Signs with Permit Requirement\)](#).

C. Procedure. See [Figure 4.05.1 Administrative Adjustment Application Procedure](#).

Figure 4.05.1. Administrative Adjustment Application Procedure

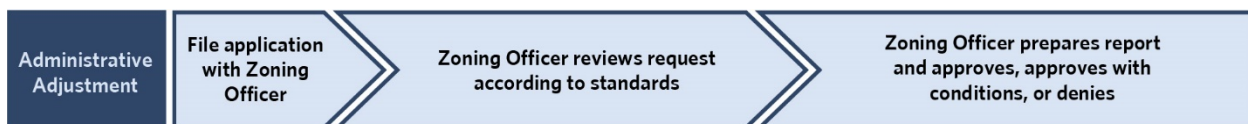

1. An application for an administrative adjustment must be filed with the Zoning Officer in accordance with [Section 2.05 \(Application Procedures\)](#).
2. Upon determining that the application is complete, the Zoning Officer must evaluate the application based upon each of the standards of Section [4.05.D \(Standards for Administrative](#)

[Adjustments](#)). The Zoning Officer may consult with other Village staff and local district representatives during the evaluation process.

3. Due to the nature of an application for an administrative adjustment, the Zoning Officer may determine that the application must be resubmitted as a variation in accordance with [Section 4.04 \(Variation\)](#) even if it meets the criteria for an administrative adjustment [Section 4.05.B \(Applicability\)](#).
 4. A property owner that receives notice of an administrative adjustment application may object to the application by written submission to the Zoning Officer, prior to the Zoning Officer's decision on the application. Any administrative adjustment application for which an objection is received from a noticed property owner must be resubmitted as a variation in accordance with [Section 4.04 \(Variation\)](#).
 5. The Zoning Officer must prepare a report and render a decision within 30 days after receipt of a complete application and take action in the form of approval, approval with conditions, or denial of the application. In approving an administrative adjustment, the Zoning Officer may:
 - a. Require conditions upon the establishment, location, construction, maintenance, and operation of the property that receives an administrative adjustment as deemed necessary to protect the public interest.
 - b. Grant an administrative adjustment less than that requested by the applicant if the Zoning Officer finds that the applicant is entitled to some deviation from the specific regulations of this Ordinance, but not to the entire amount requested, based on each of the standards of [Section 4.05.D \(Standards for Administrative Adjustments\)](#).
 6. If the Zoning Officer denies an application for an administrative adjustment, the applicant may apply for a variation in accordance with [Section 4.04 \(Variation\)](#), or appeal the decision in accordance with [Section 4.07 \(Appeal\)](#).
- D. Standards for Administrative Adjustments. The Zoning Officer must evaluate applications for administrative adjustments with specific written findings based on each of the standards of this Section.
1. The proposed administrative adjustment will not endanger the health, safety, comfort, convenience, and general welfare of the public.
 2. The proposed administrative adjustment is compatible with the character of adjacent properties and other property within the immediate vicinity of the proposed administrative adjustment.
 3. The proposed administrative adjustment alleviates an undue hardship created by the literal enforcement of this Ordinance.
 4. The proposed administrative adjustment is necessary due to the unique physical attributes of the subject property, which were not deliberately created by the applicant.
 5. The proposed administrative adjustment represents the minimum deviation from the regulations of this Ordinance necessary to accomplish the desired improvement of the subject adjustment.

- 6. The proposed administrative adjustment is consistent with the intent of the Comprehensive Plan, this Ordinance, and the other land use policies of the Village.
- E. Transferability. Administrative adjustment approval runs with the land and is not affected by changes of ownership, tenancy, or management.
- F. Expiration of Administrative Adjustment Approval. Administrative adjustment approval will expire and be revoked if any of the following conditions occur.
 - 1. A building permit has not been obtained within one year after approval of the administrative adjustment. The applicant may request one six-month extension of this period by means of a written request filed at least 30 days prior to the expiration of the initial six-month period. The Zoning Officer must decide whether to grant or deny the applicant’s request within 15 days of receipt of the applicant’s written request.
 - 2. The standards of this Ordinance or any of the terms and conditions of the administrative adjustment are violated.

4.06 Text or Map Amendment

- A. Purpose. The purpose of this text or map amendment application is to allow modifications to the text of this Ordinance and the boundaries of the Zoning Map in response to changing conditions and policies.
- B. Procedure. See [Figure 4.06.1 Text or Map Amendment Application Procedure](#).

Figure 4.06.1. Text or Map Amendment Application Procedure



- 1. Action by the Zoning Officer
 - a. An application for a text or map amendment must be filed with the Zoning Officer in accordance with [Section 2.05 \(Application Procedures\)](#).
 - b. Upon determining that the application is complete, the Zoning Officer must prepare a report for the Planning and Zoning Commission based upon a balance of the standards of [Section 4.06.C \(Standards for Zoning Amendments\)](#) and schedule the application for consideration by the Planning and Zoning Commission. The Zoning Officer may consult with other Village staff and local district representatives during the evaluation process.
- 2. Action by the Planning and Zoning Commission
 - a. The Planning and Zoning Commission must conduct a public hearing on a proposed zoning amendment in accordance with [Section 2.07 \(Public Hearing\)](#) within 60 days after receipt of a complete application. The 60-day period may be extended with the written consent of the applicant.
 - b. The Planning and Zoning Commission must evaluate the application based upon the Zoning Officer’s report, the evidence presented at the public hearing, and the standards of [Section 4.06.C \(Standards for Zoning Amendments\)](#).

- c. For text amendments, the Planning and Zoning Commission must recommend approval, approval with modifications to the proposed text, or denial of the application.
- d. For zoning map amendments, the Planning and Zoning Commission must recommend approval or denial of the application.
- e. The Planning and Zoning Commission must forward its recommendation to the Village Board within 30 days after the close of the public hearing.

3. Action by the Village Board

- a. The Village Board must consider the application within 60 days after receiving the recommendation of the Planning and Zoning Commission. The 60-day period may be extended with the written consent of the applicant.
- b. The Village Board must evaluate the application based upon the Zoning Officer's report, the recommendation of the Planning and Zoning Commission, the evidence presented at the public hearing, and the standards of [Section 4.06.C \(Standards for Zoning Amendments\)](#).
- c. For text amendments, the Village Board must take action in the form of approval, approval with modifications to the proposed text, denial, or referral of the application back to the Planning and Zoning Commission for further consideration.
- d. For zoning map amendments, the Village Board must take action in the form of approval, denial, or referral of the application back to the Planning and Zoning Commission for further consideration.
- e. A two-thirds favorable vote of the Village Trustees is required to approve the application if the Planning and Zoning Commission recommends denial of the application.
- f. A two-thirds favorable vote of the Village Trustees is required if written protest is filed with the Village Clerk against the proposed text or map amendment, signed by the owners of at least 20 percent of the frontage along, immediately adjacent to, immediately across an alley from, or directly across the street from the subject property.

C. Standards for Zoning Amendments. The Village Board, Planning and Zoning Commission, and Zoning Officer must evaluate applications for text or map amendments with specific written findings based on a balance of the standards for each type of amendment.

1. Approval Standards for Text Amendments

- a. The proposed amendment will not endanger the health, safety, comfort, convenience, and general welfare of the public.
- b. The proposed amendment corrects an error, adds clarification, or reflects a change in policy.
- c. The proposed amendment is consistent with the intent of the Comprehensive Plan, this Ordinance, and the other land use policies of the Village.

2. Approval Standards for Map Amendments

- a. The proposed amendment will not endanger the health, safety, comfort, convenience, and general welfare of the public.
- b. The proposed amendment is compatible with the existing uses, character, and zoning of adjacent properties and other property within the immediate vicinity of the proposed amendment.
- c. The proposed amendment provides a relative gain to the public, as compared to any hardship imposed upon an individual property owner.
- d. The proposed amendment addresses the community need for a specific use.
- e. The proposed amendment corrects an error, adds clarification, or reflects a change in policy.

- f. The proposed amendment is consistent with the intent of the Comprehensive Plan, this Ordinance, and the other land use policies of the Village.

4.07 Appeal

- A. Purpose. The purpose of this appeal application is to provide for the review of decisions made by the Zoning Officer in the course of carrying out the duties and responsibilities associated with this Ordinance.
- B. Initiation. An appeal may be proposed by any person that has been aggrieved or affected by a decision of the Zoning Officer pursuant to this Ordinance. An appeal must be proposed within 30 days after the date of the decision being appealed.
- C. Stay of Proceedings. An appeal will stay all proceedings of the action appealed from, unless the Zoning Officer demonstrates that a stay would cause imminent peril of life or property. The action may proceed if a stay of proceedings would cause imminent peril of life or property, unless the Village or the applicable Circuit Court files a restraining order against the applicant to stay proceedings.
- D. Procedure. See [Figure 4.07.1 Appeal Application Procedure](#).

Figure 4.07.1. Appeal Procedure

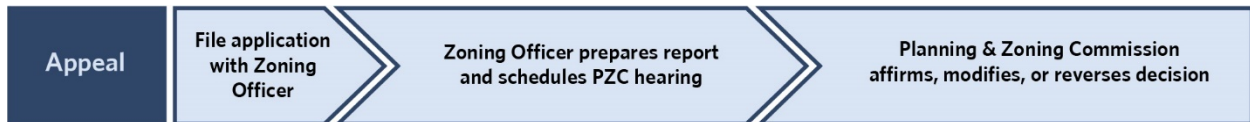

- 1. Action by the Zoning Officer
 - a. An application for an appeal must be filed with the Zoning Officer in accordance [with Section 2.05 \(Application Procedures\)](#).
 - b. Upon determining that the application is complete, the Zoning Officer must prepare a report for the Planning and Zoning Commission, and schedule the application for consideration by the Planning and Zoning Commission. The Zoning Officer may consult with other Village staff and local district representatives during the evaluation process.
- 2. Action by the Planning and Zoning Commission
 - a. The Planning and Zoning Commission must conduct a public hearing on a proposed appeal in accordance with [Section 2.07 \(Public Hearing\)](#) within 60 days after receipt of a complete application. The 60-day period may be extended with the written consent of the applicant.
 - b. The Planning and Zoning Commission must take action in the form of affirming, modifying, or reversing the decision made by the Zoning Officer.
 - c. A party aggrieved or affected by a decision of the Planning and Zoning Commission regarding an appeal may appeal this decision to the Village Board or the applicable Circuit Court. An application for appeal to the Village Board must be filed no later than 15 days following the Planning and Zoning Commission’s decision. The Village Board will consider the appeal at a public meeting within 30 days of receiving a completed application for appeal. The Village Board’s decision on appeal is a final decision.

4.08 Floodplain Development Permit

- A. Purpose. The purpose of this floodplain development application is to ensure that all development within the Village’s floodplain complies with the requirements of this Ordinance.
- B. Applicability. An applicant must not commence any development within the boundaries of the FO Floodplain Overlay District without obtaining a floodplain development permit from the Zoning Officer, unless such development is exempted by state law.
- C. Procedure. See [Figure 4.08.1 Floodplain Development Permit Application Procedure](#).

Figure 4.08.1 Floodplain Development Permit Application Procedure

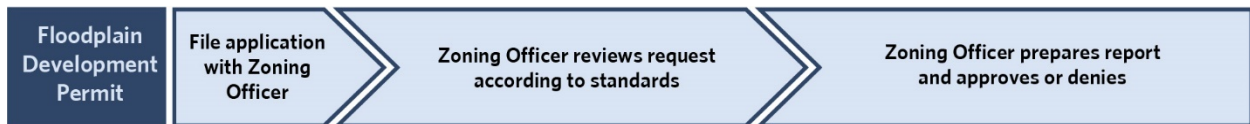

1. An application for a floodplain development permit must be filed with the Zoning Officer in accordance with [Section 2.05 \(Application Procedures\)](#).
2. Upon determining that the application is complete, the Zoning Officer must evaluate the application based upon the requirements of [Section 8.08 \(FO Floodplain Overlay District Requirements\)](#). The Zoning Officer may consult with other Village staff and local district representatives during the evaluation process.
3. The Zoning Officer must prepare a report and render a decision within 30 days after receipt of a complete application and take action in the form of approval or denial of the application.

4.09 Sign Permit

- A. Purpose. The purpose of this sign permit application is to establish a process for obtaining a permit to erect, construct, alter, or relocate signs within the Village.
- B. Applicability. An applicant must obtain a sign permit in order to erect, construct, alter, or relocate a sign, except for certain exempt permanent and temporary signs as specified in [Section 12.05.A \(Permanent Signs Allowed Without Sign Permit\)](#) and [Section 12.06.B \(Temporary Signs Allowed Without Sign Permit\)](#). The maintenance of signs does not require a sign permit and includes, but is not limited to, cleaning, painting, repairing, changing advertising copy, changing items of information, or modifying the copy of changeable copy signs.
- C. Procedure. See [Figure 4.09.1 Sign Permit Application Procedure](#).

Figure 4.09.1. Sign Permit Procedure



1. An application for a sign permit must be filed with the Zoning Officer in accordance with [Section 2.05 \(Application Procedures\)](#).
 2. Upon determining that the application is complete, the Zoning Officer must approve, approve with conditions, or deny the sign permit based on the standards of [Section 12 \(Signs\)](#) within 30 days after receipt of the complete application. The Zoning Officer may consult with other Village staff and local district representatives during the evaluation process.
- D. Expiration of Sign Permit Approval. Sign permit approval will expire and be revoked if any of the following conditions occur.
1. A building permit has not been obtained within six months after approval of the sign permit. The applicant may request one six-month extension of this period by means of a written request filed prior to the expiration of the initial six-month period. The Zoning Officer must decide whether to grant or deny the applicant’s request within 15 days of receipt of the applicant’s written request.
 2. The standards of this Ordinance or any of the terms and conditions of the sign permit are violated.

4.10 Temporary Use Permit

- A. Purpose. The purpose of this temporary use permit application is to accommodate reasonable requests for temporary uses that are desirable for the community in the short term.
- B. Applicability. An applicant must obtain a temporary use permit to establish a temporary use in accordance with [Section 9.04 \(Temporary Uses and Structures\)](#).
- C. Procedure. See [Figure 4.10.1 Temporary Use Permit Application Procedure](#).

Figure 4.10.1. Temporary Use Permit Application Procedure

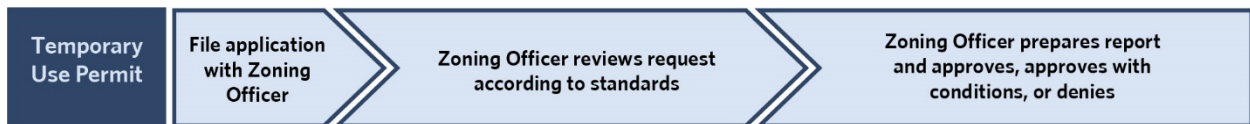

1. An application for a temporary use permit must be filed with the Zoning Officer in accordance with [Section 2.05 \(Application Procedures\)](#).
2. Upon determining that the application is complete, the Zoning Officer must approve, approve with conditions, or deny the temporary use permit based on the standards of [Section 9.04 \(Temporary Uses and Structures\)](#), within 30 days after receipt of the complete application. Temporary uses not established in [Section 9.04 \(Temporary Uses and Structures\)](#) require approval by the Village Board through a text or map amendment as established [Section 4.06 \(Text or Map Amendment\)](#). The Zoning Officer may consult with other Village staff and local district representatives during the evaluation process.
3. In approving a temporary use permit, the Zoning Officer may impose conditions upon the establishment, location, construction, maintenance, and operation of the property that receives a temporary use permit as deemed necessary to protect the public interest.

D. Standards for Temporary Uses

1. The proposed temporary use will be compatible with adjacent uses and will not adversely affect the surrounding neighborhood.
2. The proposed temporary use will provide adequate parking and will not adversely affect traffic in the surrounding neighborhood.
3. The proposed temporary use is consistent with the intent of the Comprehensive Plan, this Ordinance, and the other land use policies of the Village.

E. Expiration of Temporary Use Permit Approval. The temporary use permit is valid for the time period granted as part of the approval.

SECTION 5: PLANNED UNIT DEVELOPMENTS

[5.01 Purpose](#)

[5.02 Applicability](#)

[5.03 Procedure](#)

[5.04 Amendments to Approved Planned Unit Developments](#)

[5.05 Standards for Planned Unit Developments](#)

[5.06 Provision of Community Amenities](#)

[5.07 Expiration of Approved Planned Unit Developments](#)

5.01 Purpose

Planned unit developments are a distinct category of special use permit intended to allow flexibility in the application of the standards of this Ordinance for significant development proposals that provide amenities to the community beyond those required of conventional development applications. The planned unit development process seeks to achieve the following specific purposes:

- A. Protect and promote the health, safety, comfort, convenience, and general welfare of the public.
- B. Encourage creativity, flexibility, sustainability, and environmental sensitivity in the development of land and the design of structures.
- C. Provide for the efficient use of land to facilitate a more effective arrangement of land uses, structures, utilities, circulation systems, parking, and other facilities.
- D. Facilitate development that is consistent with Village land use policies, particularly in areas designated for potential redevelopment.
- E. Encourage development that preserves and enhances the natural features, environmental resources, watercourses, and topography of the site.
- F. Facilitate the provision of public and private open space, recreational facilities, and other amenities that will enhance the character of the site.

5.02 Applicability

- A. **Special Use Permit Standards.** A planned unit development is granted in accordance with the procedures, standards, and requirements of this Section, [Section 9.0 \(Uses\)](#), and [Section 4.03 \(Special Use Permit\)](#). A planned unit development approved as a special use may depart from the standards and requirements of this Ordinance.
- B. **Zoning District Exceptions.** Planned unit developments are subject to the regulations of the zoning district in which they are located, unless exceptions from these regulations are approved by the Village Board and found to be in accordance with [Section 5.05 \(Standards for Planned Unit Developments\)](#).
- C. **Subdivision Plats and Building Permits.** A planned unit development must be granted prior to the applicant receiving approval of a subdivision plat in accordance with [Section 3.03 \(Subdivision](#)

[Application](#)), [Section 7 \(Subdivision Development Standards\)](#), and/or a building permit in accordance with [Chapter 6 \(Buildings and Construction\) of the Municipal Code](#).

5.03 Procedure

An application for a planned unit development follows a four-step procedure, which includes a staff consultation, an optional concept plan consultation, a preliminary plan, and a final plan. The applicant may submit concurrent applications for the preliminary plan and final plan, in which case the preliminary plan and the final plan are comprised of the same document in accordance with [Section 5.03.D \(Final Plan\)](#). See [Figure 5.03.1 Planned Unit Development Application Procedure](#).

Figure 5.03.1 Planned Unit Development Application Procedure

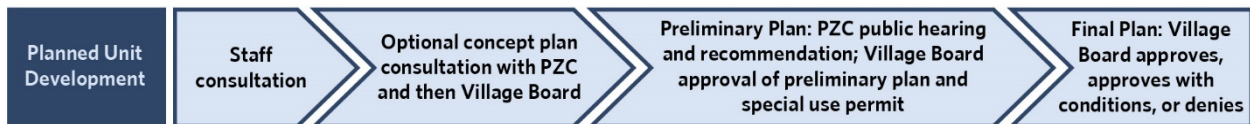

- A. Staff Consultation. The purpose of the staff consultation is to allow the applicant to receive advice and assistance from the Zoning Officer and appropriate Village staff prior to preparation of the optional concept plan or preliminary plan.
1. Action by the Zoning Officer
 - a. Prior to filing a formal application for a planned unit development, the applicant must arrange a staff consultation with the Zoning Officer to discuss the proposed planned unit development.
 - b. The Zoning Officer and appropriate Village staff must meet with the applicant to discuss the proposed planned unit development and the requirements for a planned unit development application.
 - c. The Zoning Officer may provide advice and assistance to the applicant after determining the nature of the exceptions required from this Ordinance and whether the proposal is consistent with the intent of the Comprehensive Plan and the other land use policies of the Village.
 - d. Any advice and assistance provided by the Zoning Officer and Village staff is not binding upon the Planning and Zoning Commission or Village Board with respect to the formal planned unit development application.
- B. Optional Concept Plan Consultation. The purpose of the optional concept plan consultation is to allow the applicant to obtain information and guidance from the Planning and Zoning Commission and Village Board prior to preparation of the preliminary plan.
1. Action by the Planning and Zoning Commission
 - a. Prior to filing a formal application for a planned unit development, the applicant may arrange an optional concept plan consultation with the Planning and Zoning Commission to discuss the proposed planned unit development.
 - b. The Planning and Zoning Commission may meet with the applicant to discuss the proposed planned unit development and the requirements for a planned unit development application.
 - c. The Planning and Zoning Commission may provide information and guidance to the applicant after determining the nature of the exceptions required from this Ordinance and whether the proposal is consistent with the intent of the Comprehensive Plan and the other land use policies of the Village.

- d. Any information and guidance provided by the Planning and Zoning Commission is considered advisory and is not binding upon the Planning and Zoning Commission or Village Board with respect to any formal planned unit development application.
2. Action by the Village Board
 - a. Following a meeting with the Planning and Zoning Commission to discuss a proposed planned unit development, the applicant may also arrange an optional concept plan consultation with the Village Board to discuss the proposed planned unit development.
 - b. The Village Board may meet with the applicant to discuss the proposed planned unit development and the requirements for a planned unit development application.
 - c. The Village Board may provide information and guidance to the applicant after determining the nature of the exceptions required from this Ordinance and whether the proposal is consistent with the intent of the Comprehensive Plan and the other land use policies of the Village.
 - d. Any information and guidance provided by the Village Board is considered advisory and is not binding upon the Village Board or Planning and Zoning Commission with respect to any formal planned unit development application.
- C. Preliminary Plan. The purpose of the preliminary plan is to allow the applicant to obtain a preliminary recommendation from the Planning and Zoning Commission and preliminary approval from the Village Board prior to preparation of the final plan.
1. Action by the Zoning Officer
 - a. Applications for a preliminary plan for a planned unit development and a special use permit must be filed concurrently with the Zoning Officer in accordance with [Section 2.05 \(Application Procedure\)](#) and the requirements for a planned unit development application. Applications must not be filed prior to completion of the staff consultation.
 - b. Upon determining that the application is complete, the Zoning Officer must prepare a report for the Planning and Zoning Commission based upon the standards of [Section 5.05 \(Standards for Planned Unit Developments\)](#) and [Section 4.03.E \(Standards for Special Use Permits\)](#), and schedule the application for consideration by the Planning and Zoning Commission.
 2. Action by the Planning and Zoning Commission
 - a. The Planning and Zoning Commission must conduct a public hearing on a proposed preliminary plan for a planned unit development and a special use permit in accordance with [Section 2.07 \(Public Hearing\)](#) within 60 days after receipt of a complete application. The 60-day period may be extended with the written consent of the applicant. Notice for the public hearing must be in accordance with [Section 2.06 \(Notice\)](#).
 - b. The Planning and Zoning Commission must evaluate the application based upon the Zoning Officer's report, the evidence presented at the public hearing, and the standards of [Section 5.05 \(Standards for Planned Unit Developments\)](#) and [Section 4.03.E \(Standards for Special Use Permits\)](#).
 - c. The Planning and Zoning Commission must recommend approval, approval with conditions, or denial of the application.
 - (1) In recommending approval of a preliminary plan for a planned unit development and a special use permit, the Planning and Zoning Commission may recommend conditions upon the establishment, location, construction, maintenance, and operation of the planned unit development and a special use permit as deemed necessary to protect the public interest.

- (2) In recommending approval of a preliminary plan for a planned unit development and a special use permit, the Planning and Zoning Commission may recommend guarantees from the permittee as deemed necessary to assure compliance with the stipulated conditions of approval.
 - d. The Planning and Zoning Commission must forward its recommendation to the Village Board within 30 days after the close of the public hearing.
- 3. Action by the Village Board
 - a. The Village Board must consider the application within 60 days after receiving the recommendation of the Planning and Zoning Commission. The 60-day period may be extended with the written consent of the applicant.
 - b. The Village Board must evaluate the application based upon the Zoning Officer's report, the recommendation of the Planning and Zoning Commission, the evidence presented at the public hearing, and the standards of [Section 5.05 \(Standards for Planned Unit Developments\)](#) and [Section 4.03.E \(Standards for Special Use Permits\)](#).
 - c. The Village Board must take action in the form of approval, approval with conditions, denial, or referral of the application back to the Planning and Zoning Commission for further consideration. In approving a preliminary plan for a planned unit development and a special use permit, the Village Board may:
 - (1) Identify conditions upon the establishment, location, construction, maintenance, and operation of the planned unit development and the special use as deemed necessary to protect the public interest, to be imposed at such time as final plan approval of the planned unit development is granted.
 - (2) Require guarantees from the permittee as deemed necessary to assure compliance with the stipulated conditions.
 - d. Following approval of a preliminary plan for a planned unit development and a special use permit the applicant may submit a final plan for the planned unit development.
- D. Final Plan. The purpose of the final plan is to allow the applicant to obtain final approval of the planned unit development from the Village Board.
 - 1. Action by the Zoning Officer
 - a. Applications for a final plan for a planned unit development must be filed with the Zoning Officer in accordance with [Section 2.05 \(Application Procedure\)](#) and the requirements for a planned unit development application. Applications must be filed within one year after approval of the preliminary plan.
 - b. Upon determining that the application is complete, the Zoning Officer must determine whether the final plan is in conformance with the approved preliminary plan and any conditions and guarantees deemed necessary by the Village Board.
 - c. If the final plan is in substantial conformance with the approved preliminary plan, the Zoning Officer must prepare a report for the Village Board recommending approval of the final plan and schedule the application for consideration by the Village Board.
 - d. If the final plan is not in substantial conformance with the approved preliminary plan, the Zoning Officer must allow the applicant to revise any parts of the application that are not in substantial conformance with the preliminary plan prior to preparing the report, and allow the applicant to resubmit the application as a final plan in accordance with the requirements of this Section.

2. Action by the Village Board
 - a. The Village Board must consider the application within 30 days after receiving the report of the Zoning Officer recommending approval of the final plan. The 30-day period may be extended with the written consent of the applicant.
 - b. The Village Board must take action in the form of approval, approval with conditions, or denial of the application.
 - c. Upon approval of the final plan by the Village Board, the use of land and the construction or modification of any buildings or structures on the site will be governed by the approved final plan rather than by other provisions of this Ordinance.

5.04 Amendment to Approved Planned Unit Developments

A final plan for an approved planned unit development may be amended in accordance with the requirements of this Section.

- A. Major Amendments. Any change to an approved final plan that substantially affects the essential design, composition, and character of the planned unit development is considered a major amendment. Any amendment that is not established as a minor amendment [in Section 5.04.B \(Minor Amendments\)](#) is considered a major amendment. The Village Board must make a decision on a request for a major amendment after receiving a recommendation from the Planning and Zoning Commission in accordance with [Section 5.03.C \(Preliminary Plan\)](#).
- B. Minor Amendments. Any change to an approved final plan that minimally affects the essential design, composition, and character of the planned unit development is considered a minor amendment. The Zoning Officer must make a decision on a request for a minor amendment in accordance with [5.03.C \(Preliminary Plan\)](#). The Zoning Officer may determine that the application must be resubmitted as a major amendment in accordance with [Section 5.04.A \(Major Amendments\)](#). Minor amendments include the following:
 1. Any change in the proportion of land uses in the development by less than 10 percentage points.
 2. Any change in the gross floor area of the development by less than five percent.
 3. Any change in the building height of the development by less than five percent.
 4. Any change in the proportion of the impervious coverage of the development by less than five percentage points.
 5. Any change in the location or dimensions of walkways, driveways, streets, parking facilities, and loading facilities within the development by less than five feet.
 6. Any change in the number of off-street parking spaces provided within the development by less than 10 percent.

5.05 Standards for Planned Unit Developments

The Village Board, Planning and Zoning Commission, and Zoning Officer must evaluate applications for planned unit developments with specific written findings based on a balance of both the standards of

this Section and the standards for special use permits in accordance with [Section 4.03.E \(Standards for Special Use Permits\)](#).

- A. The proposed planned unit development fulfills the objectives of the Comprehensive Plan and the other land use policies of the Village, through an innovative and creative approach to the development of land.
- B. The proposed planned unit development will provide walkways, driveways, streets, parking facilities, loading facilities, exterior lighting, and traffic control devices that adequately serve the uses within the development, promote improved access to public transportation, and provide for safe motor vehicle, bicycle, and pedestrian traffic to and from the site.
- C. The proposed planned unit development will provide landscaping and screening that enhances the Village's character and livability, improves air and water quality, reduces noise, provides buffers, and facilitates transitions between different types of uses.
- D. The proposed planned unit development will incorporate sustainable and low impact site design and development principles.
- E. The proposed planned unit development will protect the community's natural environment to the greatest extent practical, including existing natural features, water courses, trees, and native vegetation.
- F. The proposed planned unit development will be provided with underground installation of utilities when feasible, including electricity, cable, and telephone, as well as appropriate facilities for storm sewers, stormwater retention, and stormwater detention.

5.06 Provision of Community Amenities

Planned unit developments may be granted specific exceptions from zoning district regulations if the applicant demonstrates that the development will provide amenities to the Village that are not required from conventional development applications. The amenities to be considered by the Village Board, Planning and Zoning Commission, and Zoning Officer must be appropriate for the scale of the planned unit development and may include, but are not limited to, the following:

- A. Establishment of community amenities, such as plazas, gardens, public art features, outdoor seating areas, pedestrian facilities, and transit facilities.
- B. Establishment of open space amenities, such as playing fields, playgrounds, swimming pools, and fitness facilities.
- C. Enhancement of the community's natural environment, including existing natural features, water courses, trees, and native vegetation.
- D. Preservation and enhancement of the community's cultural resources and historic places.
- E. Provision of public infrastructure improvements that exceed the requirements of the planned unit development, such as interconnected streets without dead end streets or cul-de-sacs, enhancements to rights-of-way, stormwater management systems, and sewer systems.

- F. Incorporation of sustainable development techniques, such as meeting the requirements of LEED or LEED-equivalent rating systems.
- G. Provision of residential dwelling units for affordable housing or senior housing.
- H. Provision of residential dwelling units with accessible features that exceed the requirements of the Americans with Disabilities Act.

5.07 Expiration of Approved Planned Unit Developments

- A. Expiration of Preliminary Plan Approval. Preliminary plan approval will expire and be revoked if a complete application for the final plan has not been approved within one year after approval of the preliminary plan by the Village Board.
- B. Expiration of Final Plan Approval. Final plan approval will expire and be revoked if a building permit has not been approved within one year after approval of the final plan by the Village Board.
- C. Extension of Approval. The applicant may extend this one-year period by means of a written request filed with the Zoning Officer at least 30 days prior to the expiration of the period. The Zoning Officer must decide whether to grant or deny the applicant's request within 15 days of receipt of the applicant's written request.

SECTION 6: NONCONFORMITIES

[6.01 Purpose](#)

[6.02 Applicability](#)

[6.03 Nonconforming Uses](#)

[6.04 Nonconforming Structures](#)

[6.05 Nonconforming Lots of Record](#)

[6.06 Nonconforming Site Elements](#)

6.01 Purpose

The purpose of this Section is to regulate uses, structures, lots, and site elements that were in compliance with previous development regulations, but do not conform to current development regulations as a result of adoption of or amendments to this Ordinance. The intent of this Section is to specify the circumstances under which legal nonconforming uses, structures, lots, and site elements may be continued, altered, or expanded, as well as circumstances under which such nonconformities must be gradually eliminated.

6.02 Applicability

A. Authority to Continue.

1. Any use, structure, lot, or site element that was established legally as of the effective date of this Ordinance, or its subsequent amendments, may continue as long as it remains lawful.
2. Any use, structure, lot, or site element that was established legally as of the effective date of this Ordinance, or its subsequent amendments, and has been made nonconforming due to the regulations of this Ordinance, or its subsequent amendments, is a legal nonconforming use, structure, lot, or site element and may continue subject to the provisions of this Section as long as it remains otherwise lawful.
3. Any use, structure, lot, or site element that was established illegally as of the effective date of this Ordinance, or its subsequent amendments, will remain illegal if it does not conform with the requirements of this Ordinance.

B. Nonconforming Status. The legal nonconforming status of a nonconforming use, structure, lot, or site elements rests with the property and is not affected by changes in property ownership, tenancy, or management.

C. Burden of Establishing Legal Status. The burden of establishing the legal status of a nonconforming use, structure, lot, or site element under the provisions of this Ordinance is the responsibility of the owner of such use, structure, lot, or site element.

6.03 Nonconforming Uses¹

¹ Amended per Ordinance 1929.

- A. Applicability. A legal nonconforming use is the use of land or a structure that at one time conformed to applicable development regulations, but no longer conforms due to subsequent amendments to this Ordinance.
- B. Expansion. A legal nonconforming use must not be expanded, enlarged, or increased in intensity to include any land area or structure not previously occupied by such legal nonconforming use.
- C. Relocation. A legal nonconforming use must not be relocated on the same lot or any other lot unless the relocation of such use meets the requirements of the zoning district in which the use is relocated.
- D. Change of Use. A legal nonconforming use must not be changed to any other use unless the use is allowed within the zoning district in which the use is located.
- E. Discontinuation or Abandonment. If a legal nonconforming use is discontinued, or the structure that it occupies becomes vacant or remains unoccupied for a period of six consecutive months, such use is deemed abandoned and must not be reestablished regardless of the intent to continue the use. Any period of discontinuance or abandonment caused by a government action or an act of nature is not included in the six-month period. Any subsequent use or occupancy of such land or structure must meet the requirements of the zoning district in which the use is located.
- F. Damage or Destruction.
 - 1. In the event that a building or structure containing a legal nonconforming use is damaged or destroyed to the extent of 50 percent or more of its replacement value, the building or other structure can be rebuilt or used thereafter only for a conforming use and in compliance with the provisions of the district in which it is located.
 - 2. In the event the that a building or structure containing a legal nonconforming use is damaged or destroyed less than 50 percent of its replacement value, the building or structure may then be restored to its original condition and the occupancy or use of such building may be continued which existed at the time of such partial destruction provided that a building permit is obtained for such repairs within six months of the date of damage or destruction, and such repairs are completed within one year of issuance of the building permit.
 - 3. Residential Nonconforming Use: A single family home which is a nonconforming use in any zoning district can be rebuilt, if damaged or destroyed to the extent of 50 percent or more of its replacement value, provided that the residence is occupied by the owner thereof and all other provisions of this ordinance regarding nonconformance are complied with.
 - 4. The replacement value of the structure is established by one of the following methods:
 - a. The sale of the structure within the previous year.
 - b. An appraisal of the structure within the last two years.
 - c. The amount for which the structure was insured prior to the date of damage or destruction.
 - d. An alternative method determined acceptable by the Village.

6.04 Nonconforming Structures

- A. Applicability. A legal nonconforming structure is a principal or accessory structure that at one time conformed to applicable development regulations, but no longer conforms due to subsequent amendments to this Ordinance.

- B. Ordinary Maintenance and Repair. Ordinary maintenance and repair may be performed on any legal nonconforming structure provided that such activities will not create any new nonconformity or increase the extent of any existing nonconformity.
- C. Structural Alterations, Enlargements, and Additions. Structural alterations, enlargements, and additions must not be performed on any legal nonconforming structure, except in the following situations:
1. When the alteration, enlargement, or addition is required by law or is necessary to restore the structure to a safe condition upon the order of any official representative of the Village.
 2. When the alteration, enlargement, or addition is for the purpose of creating a conforming structure.
 3. When the alteration, enlargement, or addition will not create any new nonconformity or increase the extent of any existing nonconformity.
 4. When the alteration, enlargement, or addition extends the existing perimeter walls of a structure in the MD Mill District with nonconforming setbacks provided that the resulting structure will not create any new nonconformity or increase the extent of any existing nonconformity. Refer to [Figure 6.04.1 Extension of Nonconforming Perimeter Walls](#).
 5. When the alteration, enlargement, or addition develops a sustainable accessory structure, such as a rainwater cistern, small wind energy system, or solar energy collection system.
 6. When the alteration, enlargement, or addition provides exterior lighting.

Figure 6.04.1 Extension of Nonconforming Perimeter Walls

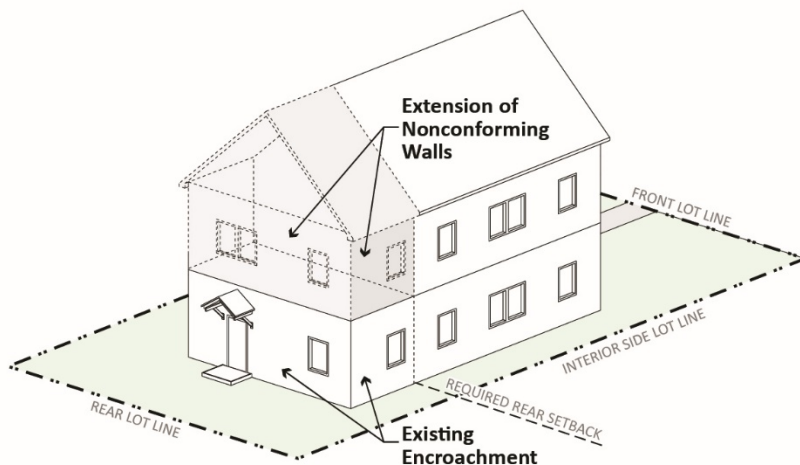

- D. Relocation. A legal nonconforming structure must not be relocated on the same lot or any other lot unless the relocation of such structure meets the requirements of the zoning district to which the structure is relocated.

E. Damage or Destruction.

1. In the event that a legal nonconforming structure is damaged or destroyed to the extent of 50 percent or more of its replacement value, then the structure may not be repaired unless it meets the requirements of the zoning district in which the structure is located.
2. In the event that a legal nonconforming structure is damaged or destroyed to the extent of less than 50 percent of its replacement value, the structure may be repaired provided that:
 - a. The repairs will not create any new nonconformity or increase the extent of any existing nonconformity.
 - b. A building permit is obtained for such repairs within six months of the date of damage or destruction, and such repairs are completed within one year of issuance of the building permit.
3. The replacement value of the legal nonconforming structure is established by one of the following methods:
 - a. The sale of the structure within the previous year.
 - b. An appraisal of the structure within the last two years.
 - c. The amount for which the structure was insured prior to the date of damage or destruction.
 - d. An alternative method determined acceptable by the Village.

6.05 Nonconforming Lots of Record

- A. Applicability. A legal nonconforming lot of record is a lot of record that at one time conformed to applicable development regulations, but no longer conforms due to subsequent amendments to this Ordinance.
- B. Contiguous Nonconforming Lots of Record. If two or more contiguous lots of record are owned by a single party, or by related parties, and one or more of the lots does not meet the requirements for lot area or lot width as established by this Ordinance, then the lots of record must be developed as a single entity. A building permit will not be issued for the development of such contiguous lots of record in violation of this Section.
- C. Individual Nonconforming Lots of Record in Residential Districts. Any legal nonconforming lot of record may be developed provided the principal structure meets all of the bulk and setback requirements of the zoning district in which it is located and that the owner of that lot of record, or a related party, does not own any lots of record that are contiguous to the subject lot of record.

6.06 Nonconforming Site Elements

- A. Applicability. A legal nonconforming site element is a site characteristic that at one time conformed to applicable development regulations, but no longer conforms due to subsequent amendments to this Ordinance. For the purposes of this section, legal nonconforming site elements include impervious site coverage, off-street parking and loading, landscaping, lighting, signs, or other similar characteristics of a site.
- B. Ordinary Maintenance and Repair. Ordinary maintenance and repair may be performed on any legal nonconforming site element provided that such activities will not increase any new nonconformity or

increase the extent of any existing nonconformity. The faces of nonconforming signs may be replaced if a building permit is obtained for such repairs, as long as no new electrical equipment is installed.

C. Relocation. A legal nonconforming site element may not be relocated on the same lot or any other lot unless the relocation of such site element meets the requirements of the zoning district in which the site element is relocated.

D. Damage or Destruction.

1. In the event that a legal nonconforming site element is damaged or destroyed to the extent of 50 percent or more of its replacement value, then the site element may not be repaired unless it meets the requirements of the zoning district in which the site element is located.
2. In the event that a legal nonconforming site element is damaged or destroyed to the extent of less than 50 percent of its replacement value, the site element may be repaired provided that:
 - a. The repairs will not create any new nonconformity or increase the extent of any existing nonconformity.
 - b. A building permit is obtained for such repairs within six months of the date of damage or destruction, and such repairs are completed within one year of issuance of the building permit.
3. The replacement value of the legal nonconforming site element is established by one of the following methods:
 - a. Two estimates of the cost of replacement of the site element by independent contractors.
 - b. The amount for which the site element was insured prior to the date of damage or destruction.
 - c. An alternative method determined acceptable by the Village.

E. Discontinuation or Abandonment of Nonconforming Signs. A legal nonconforming sign must not remain in use if the property on which the sign is located is vacant and unoccupied for a period of three months or more.

SECTION 7: SUBDIVISION DEVELOPMENT STANDARDS

[7.01 General Provisions](#)

[7.02 Subdivision Design and Layout](#)

[7.03 Conservation and Cluster Subdivision Design](#)

[7.04 Street Standards](#)

[7.05 Required Public Improvements](#)

[7.06 Cash and Land Donations](#)

7.01 General Provisions

- A. Purpose. The purpose of this Section is to regulate the subdivision and development of land; establish a comprehensible street system that facilitates all modes of travel; supply water, sewage disposal, and other utilities; provide stormwater management; and to meet the goals of the Village's Comprehensive Plan and the other land use policies of the Village to promote public health, safety, and welfare.
- B. Applicability. The provisions of this Section apply to all parcels of land being subdivided within the corporate limits of the Village and unincorporated parcels within one and a half miles of the Village boundary that are under the Village's jurisdiction.
- C. Subdivision Applications. Applications for the subdivision of land must be submitted in accordance with [Section 3 \(Annexation and Subdivision Application Approval Procedures\)](#).
- D. Conservation Features Inventory. A conservation features inventory is required for any subdivision of previously undeveloped land or land previously in agricultural use to determine whether the subdivision must follow conservation subdivision design in accordance with [Section 7.03 \(Conservation and Cluster Subdivision Design\)](#).
- E. Special Flood Hazard Area Review.
 1. Known Flood Hazards. The Zoning Officer will take known flood hazards into account in all official actions related to subdivisions and must obtain the most recent Special Flood Hazard Area maps and data for any areas being considered for subdivision.
 2. Drainage of Surface Waters. Plats for new subdivisions must include a signed statement by a professional engineer that the plat accounts for changes in the drainage of surface waters in accordance with the [Plat Act \(765 ILCS 205\)](#). Plats for new subdivisions must include the following:
 - a. The boundary of the Special Flood Hazard Area.
 - b. The boundary of the floodway shown on the Special Flood Hazard Area maps
 - c. Easements dedicated to the Village for channel maintenance purposes.
 - d. The base flood elevation for each building site.
 3. Plans for Development. Plans for the development in the Special Flood Hazard Area must be reviewed by the Zoning Officer to ensure that they comply with this Section.

7.02 Subdivision Design and Layout

A. Applicability. The following requirements for blocks, lots, and bicycle and pedestrian connectivity apply to all subdivisions.

B. Blocks.

1. Block Configuration. The shape of a block must be generally rectangular when feasible, but may vary based on topography, natural features, or site constraints. Blocks should be two lots deep when feasible.
2. Block Length and Size. The maximum block length must be 800 feet and the maximum block perimeter must be 2,400 feet. Refer to [Figure 7.02.1 Maximum Block Length and Size](#).

Figure 7.02.1 Maximum Block Length and Size

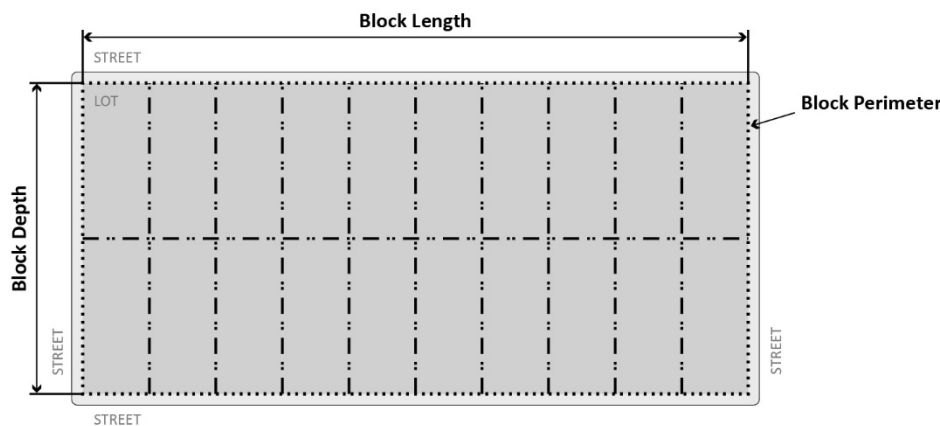

C. Lots.

1. Lot Dimensions. All lots of record must be developed to meet the applicable zoning district requirements, such as lot area, lot width, building height, impervious coverage, and setbacks, established in [Section 8 \(Zoning District Regulations\)](#).
2. Lot Configuration. The shape of a lot must be generally rectangular when feasible, but may vary based on topography, natural features, or site constraints.
3. Lot Access. All lots must have frontage along a public right-of-way.
4. Lot Shape. Interior side lot lines must be perpendicular to the right-of-way to the extent practical.
5. Through Lots. The creation of new through lots is prohibited unless subdivision of an existing through lot results in a new through lot.
6. Flag Lots. Flag lots are prohibited.
7. Lots Adjacent to Arterial and Collector Streets. For lots whose rear lot line is adjacent to an arterial or collector street, a landscaped minimum of 10 feet must be provided along the rear lot line.

8. Lot Orientation. Lot orientation along an east-west longitudinal axis is recommended for increased energy efficiency.
9. Subdivisions Adjacent to Water. Newly platted lots must not include any portion of a navigable body of water, such as the Fox River, Waubensee Creek, and Blackberry Creek. Such bodies of water must remain public domain and be indicated as separate outlots on plats.

D. Bicycle and Pedestrian Connectivity.

1. Connections to Adjacent Systems. Developments must connect to all adjacent planned or existing pedestrian, bicycle, and multi-use paths, and trail systems. Paths and trails must be dedicated or platted in easements to ensure public access.
2. Minimum Connections. Developments must provide a bicycle or pedestrian path connection a minimum of every 800 feet along blocks that are adjacent to developable land.
3. Mid-Block Pedestrian Access. Mid-block pedestrian access must be provided along a public easement between lots at the approximate center of the block for all blocks longer than 800 feet. This access must meet the standard for pedestrian crossings connection in [Section 7.04.C.2.a \(Cul-de-Sac Streets\)](#). Refer to [Figure 7.02.2 Required Mid-Block Pedestrian Access](#).

Figure 7.02.2 Required Mid-Block Pedestrian Access

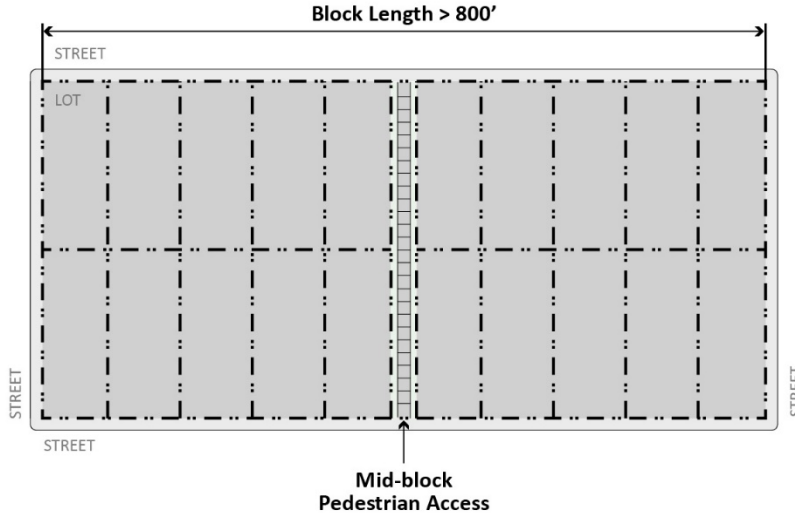

4. Internal Circulation. An internal circulation system must provide pedestrian and bicycle paths within or adjacent to the development.
5. Additional Connections. The Village may require additional bike and pedestrian connections for subdivisions that will receive significant use from the development, such as in the vicinity of schools, playgrounds, parks, shopping areas, or other uses.

7.03 Conservation and Cluster Subdivision Design

- A. Applicability. The provisions of this Section apply to subdivisions that are developed through conservation or cluster design.
1. Conservation Subdivision Design. Conservation subdivision design is required if a conservation features inventory indicates that 20 percent or more of the total land area of a subdivision contains significant natural resources. Conservation subdivision design is a process that requires a percentage of open space to be conserved while allowing for an increase in the density of lots in a development as compared to conventional subdivision design. Conservation subdivision design is intended to promote environmentally sensitive development, preserve common open space, and achieve a balance between well-designed neighborhoods and natural resource protection.
 2. Cluster Subdivision Design. Cluster subdivision design is an optional subdivision process. A conservation features inventory may be utilized in the planning and design of a cluster subdivision, but is not required. Cluster subdivision design is a process that allows for groupings of smaller lots that do not increase the overall density of a development as compared to conventional subdivision layout. Cluster subdivision design is intended to promote environmentally sensitive development, preserve common open space, and achieve a balance between well-designed neighborhoods and natural resource protection.
- B. Conservation Features Inventory Required. A conservation features inventory (CFI) is required for any subdivision of previously undeveloped land or land previously in agricultural use. The CFI must be submitted prior to the preliminary plat.
- C. Conservation Subdivision Design Standards.²
1. Location. Conservation subdivision is permitted in the A, R-1, R-2, R-3, R-4, and R-5 Districts.
 2. Density. Conservation subdivisions may reduce the minimum lot sizes established in [Section 8 \(Zoning District Regulations\)](#) by 50 percent.
 3. Bulk and Setback Standards. Conservation subdivisions are exempt from the minimum lot area and lot width standards of the zoning district where they are located. The building height, impervious coverage, and setback standards of the R-3 District apply to all conservation subdivisions.
 4. Required Common Open Space. Lots must be organized around access to common open space. 40 percent of the land area in a conservation design must be maintained as active or passive common open space in accordance with [7.03.E \(Common Open Space\)](#).
 5. Conservation Elements.
 - a. Development must be configured to protect areas of conservation value identified in the CFI.
 - b. Development must be located to minimize negative impacts on the natural, scenic, and cultural resources of the site.
 - c. Downstream impacts must be minimized through adequate on-site stormwater management.

² Amended per Ordinance 1929.

- d. Contiguous areas of undisturbed or restored habitat must be preserved to create corridors for the movement of wildlife and natural resources. Fragmentation and clear-cutting of woodland areas and other natural ecosystems is prohibited.
- e. The development must preserve scenic natural views, including scenic views from roadways.

6. Residential Lot Configuration. Residential dwellings must be configured in groups of up to 30 dwelling units. Groups of residential lots must be located a minimum of 150 feet apart, as measured from lot line to lot line. The groups of residential lots must be separated by greenbelts or other natural features. Development is not permitted within these separation areas, but these areas may include pedestrian, bicycle, and multi-use paths, and trail systems.

7. Perimeter Buffer Yard. A conservation subdivision must have a perimeter buffer yard of at least 50 feet around the entire subdivision. Development is not permitted in the perimeter buffer yard, but these areas may include pedestrian, bicycle, and multi-use paths, and trail systems. The perimeter buffer yard may be included as part of the required common open space if it is restricted from future development.

D. Cluster Design Standards.³

1. Location. Cluster subdivision is permitted in the A, R-1, R-2, R-3, R-4, and R-5 Districts.

2. Density. Cluster subdivisions may reduce the minimum lot sizes established in [Section 8 \(Zoning District Regulations\)](#) by 50 percent.

3. Bulk and Setback Standards. Cluster subdivisions are exempt from the minimum lot area and lot width standards of the zoning district where they are located. The building height, impervious coverage, and setback standards of the R-3 District apply to all cluster subdivisions.

4. Required Common Open Space. Lots must be organized around access to common open space. 25 percent of the land area in a cluster design must be maintained as active or passive common open space in accordance with [7.03.E \(Common Open Space\)](#).

E. Common Open Space.

1. Common Open Space Types. Required common open space must be accessible to the residents of the development. The open space may also be available to the general public. The open space must be undivided and restricted from future development. The following types of common open space are permitted:

- a. Natural water bodies, wetlands, and conservation areas. However, a maximum of 20 percent of the common open space may consist of water bodies, wetlands, or floodplains.
- b. Detention and retention areas designed as wetlands or natural water features with native vegetation.
- c. Hiking trails and greenways connecting open space areas.
- d. Parks, playgrounds, and recreational facilities, such as ball courts and swimming pools. A maximum of 30 percent of the open space may be used for structures for recreational facilities.

³ Amended per Ordinance 1929.

- e. Botanical gardens, greenhouses, and community gardens.
 - f. Agricultural uses, including the reuse of existing barns or silos located on site.
2. Not Considered Common Open Space. The following are allowed on site, but are not considered common open space.
- a. Yards on individual lots.
 - b. Public rights-of-way.
 - c. Off-street parking and loading areas.
 - d. Golf courses.
3. Management Plan. A management plan must be submitted for all common open space, including any detention and retention ponds serving more than one property. The designated common open space must be owned and managed by one or more of the following entities and the management plan must meet the standards for each type of plan.
- a. Homeowners Association.
 - (1) The developer must provide the Village with a description of the association, proof of incorporation, its bylaws, a declaration of covenants, easements, or restrictions, or similar documents regulating the use of the property and establishing procedures for maintaining the open space. The documents must include a description of how control of the association will be transferred from the developer to the homeowners.
 - (2) Maintenance and insurance of common open space can either be the responsibility of the association or can be incorporated into a Special Service Area (SSA). An SSA is required to be established for all stormwater improvements per the Village's Stormwater Ordinance. Other common open space may also be included in an SSA. If an SSA is the selected maintenance option, the Village will administer the SSA as a part of the Village's existing program and will oversee contractors and levy sufficient funds to conduct proper maintenance.
 - (3) Membership in the association is mandatory for all property owners within the subdivision. The members of the association must share the costs of maintaining common open space owned by the association.
 - (4) The association must have adequate staff to properly maintain common open space or lease common open space to another party for operation and maintenance.
 - (5) The association's documentation must be recorded with the final plat of subdivision in accordance with [Section 3.03 \(Subdivision Applications\)](#).
 - b. Private Conservation Organization. With the permission of the Village, the developer may transfer the common open space, or easements on the open space, to a private conservation organization in accordance with the following standards.
 - (1) The organization must be a well-established conservation organization whose purpose is to conserve open space and/or natural resource areas.
 - (2) The transfer must include provisions to allow the conservation organization to return the common open space to the property owners in the event that the organization becomes unable to carry out its responsibilities.
 - (3) The transfer must include a maintenance agreement for the common open space in a format that is acceptable to the Village.
 - c. Private Ownership. With the permission of the Village, an individual may maintain the common open space as provided by a conservation easement. The private ownership option may be used for unique situations where no other options are practical.

7.04 Street Standards

- A. Applicability. The provisions of this Section apply to all new or reconstructed streets approved in accordance with this Ordinance.
- B. General Requirements.
1. Street Types. All new streets must meet the design standards required by this Section. Street types must be approved by the Village Board pursuant to the recommendation of the Planning and Zoning Commission based on the objectives of the Village's Comprehensive Plan and the other land use policies of the Village. Street type approval and subdivision approval must occur simultaneously in accordance with [Section 3 \(Annexation and Subdivision Application Approval Procedures\)](#).
 2. Public Use. All streets must be available for public use at all times. Gated streets are not permitted.
 3. Right-of-Way Features. The developer must dedicate additional rights-of-way to accommodate all right-of-way features required by this Section if the requirements cannot be met within the existing right-of-way.
 4. Street Names. New street names must not duplicate any existing street name in the Village except if a new street is a continuation of an existing street. The sound or spelling of new street names must not be substantially similar to the names of existing streets.
- C. Street Design Standards for All Street Types.
1. Interconnected Streets. The network of streets must form an interconnected grid pattern and provide for the continuation of existing streets into new subdivisions.
 2. Disconnected Streets.
 - a. Cul-de-Sac Streets. Cul-de-sac streets are discouraged and are allowed only when approved by the Zoning Officer in consultation with the Village Engineer. Cul-de-sacs may be allowed due to site constraints such as topography, natural features, railroad tracks, or raised highways. Cul-de-sacs must provide pedestrian and bicyclist access according to the following standards.
 - (1) Cul-de-sacs must provide pedestrian and bicyclist access along a public easement located between lots of record when the center point of the cul-de-sac is within 350 feet of a street or another cul-de-sac. Refer to [Figure 7.04.1 \(Pedestrian Connection from Cul-de-Sac\)](#).
 - (2) The public easement must be a minimum of 20 feet wide.
 - (3) The public easement must include a lighted multi-use path with a minimum width of 10 feet that is constructed of a permanent surface approved by the Zoning Officer in consultation with the Village Engineer.
 - (4) Maintenance of the easement must be designated in the final plat of subdivision.

Figure 7.04.1 Pedestrian Connection from Cul-de-Sac

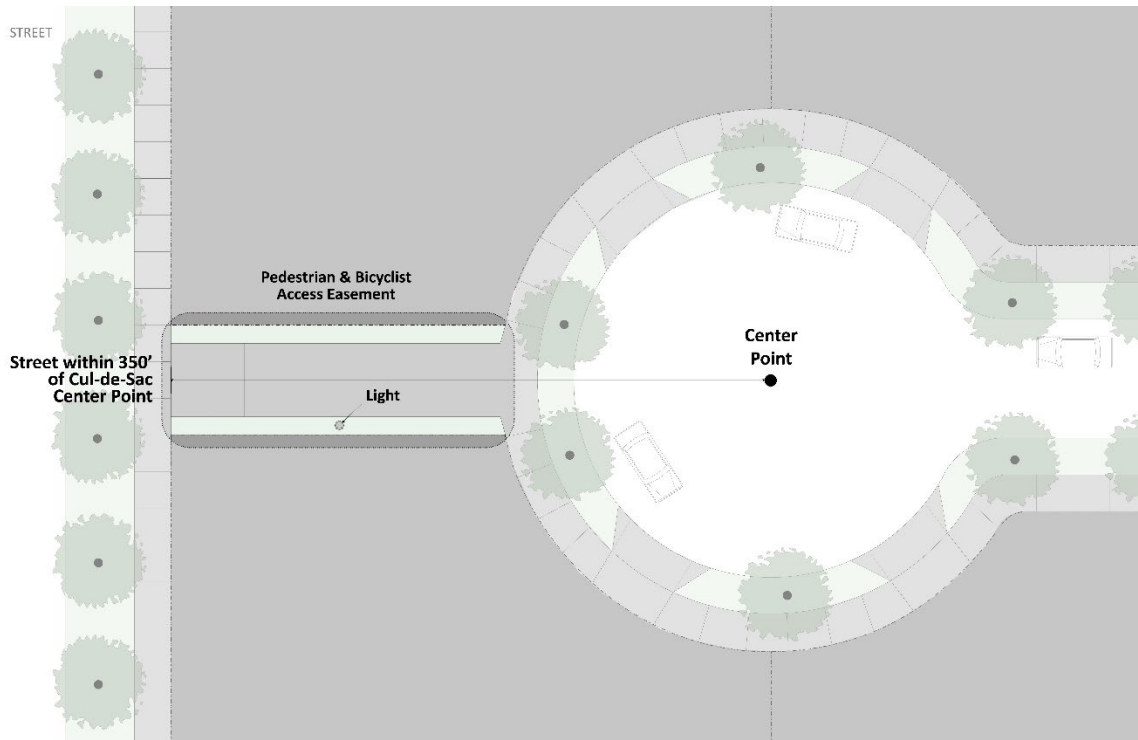

- b. Stub Streets. Stub streets must be extended to the boundary line of land that is not subdivided to provide for future street connections.
 - c. Half Streets. Half streets are prohibited unless otherwise approved by the Zoning Officer in consultation with the Village Engineer. Half streets may be allowed if the Village receives satisfactory assurance for dedication of the remaining half of the street when adjacent property is subdivided.
 - (1) Proposed half streets must dedicate and construct at least one half of the right-of-way according to the applicable design standards for an entire street.
 - (2) If a half street is adjacent to a proposed subdivision, the other half of the street must be platted within the proposed subdivision, and the remaining right-of-way improvements constructed.
3. Intersection Design and Alignment.
- a. Alignment of New Streets. New streets must be aligned with existing streets when feasible to form intersections.
 - b. Number of Streets. A maximum of two streets may intersect at any point.
 - c. Angle of Intersection. Streets must be aligned to intersect at right angles whenever possible. In all cases, the angle of intersection for center lines must be 80 to 100 degrees.
 - d. Centerline Offsets. The centerlines of intersections must be offset by a minimum distance of 150 feet, see [Figure 7.04.2 Centerline Offsets](#).

Figure 7.04.2 Centerline Offsets

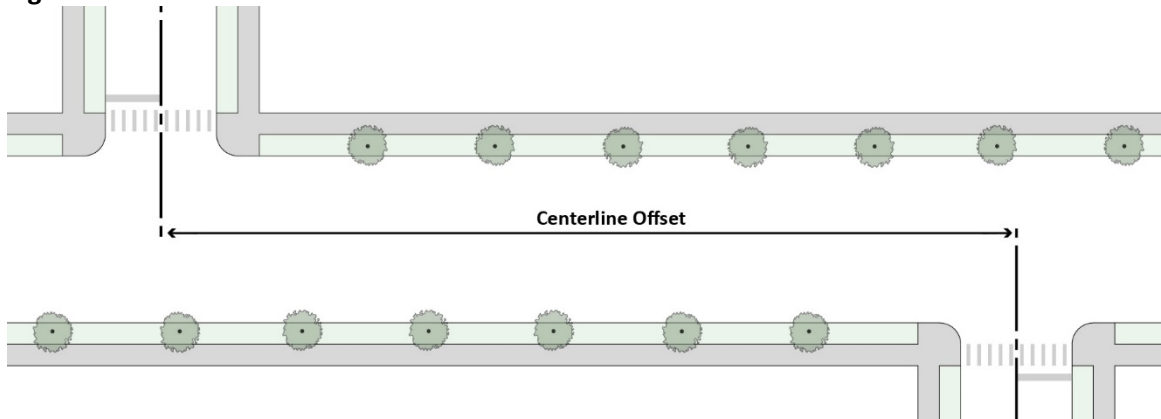

- e. Clear Sight Distance. Minimum clear sight distance at all intersections must be provided in accordance with [Section 8.05.C \(Visibility Obstruction\)](#), the Montgomery Engineering Design and Inspection Policy Manual, and other applicable guidelines, see [Section 7.05.I \(Street Construction\)](#).
 - f. Alignment of Curved Streets. The horizontal and vertical alignment of curved streets must be provide in accordance with the Montgomery Engineering Design and Inspection Policy Manual and other applicable guidelines, see [Section 7.05.I \(Street Construction\)](#).
4. Crosswalks.
- a. Location. Crosswalks are required at all intersections.
 - b. Dimensions. Crosswalks must be a minimum of six feet in width per the Manual on Uniform Traffic Control Devices.
 - c. Markings. Crosswalks must be highly visible with painted markings and/or textured or colored pavement, in accordance with the Montgomery Engineering Design and Inspection Policy Manual.
 - d. Pedestrian Crossing Distances. Pavement width at crosswalks must be a maximum of 38 feet to encourage pedestrian safety. Rights-of-way may include median pedestrian refuge areas, curb extensions, or other acceptable pedestrian facilities to meet the maximum pedestrian crossing distance. Refer to [Figure 7.04.4 Pedestrian Crossing Distances](#).

Figure 7.04.4 Pedestrian Crossing Distances

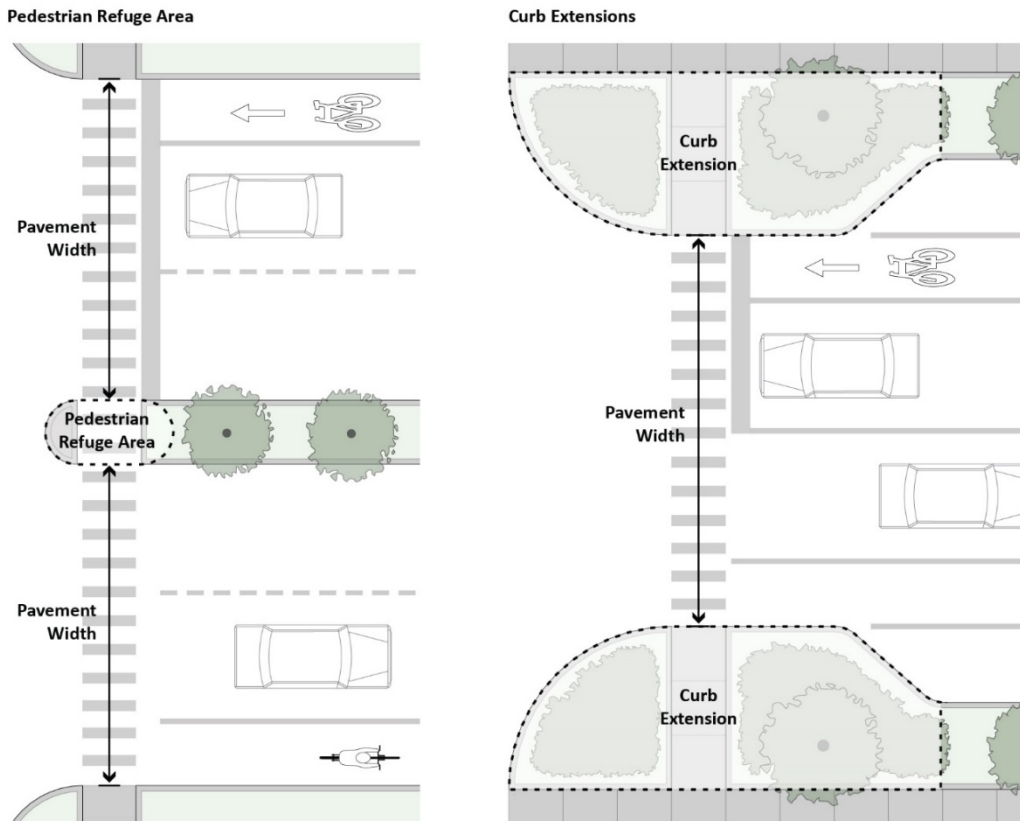

- e. Median Pedestrian Refuge. At any intersection requiring a pedestrian to cross more than three vehicle lanes, a median pedestrian refuge must be installed to provide adequate pedestrian safety. The pedestrian refuge cut-through or ramp must be the same width as the crosswalk. Refer to [Figure 7.04.5 Median Pedestrian Refuge Design](#).

Figure 7.04.5 Median Pedestrian Refuge Design

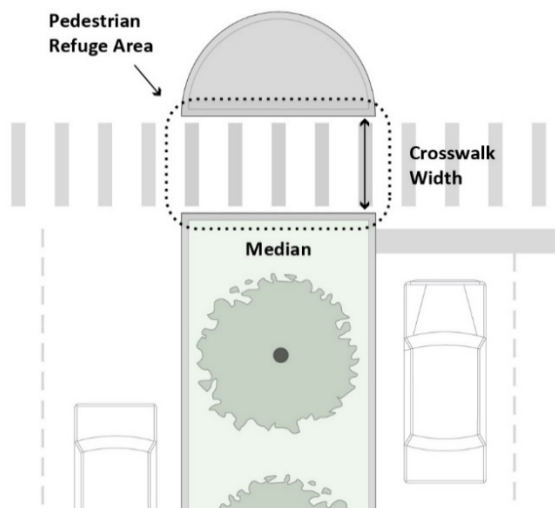

5. Curb Extensions. Curb extensions must be installed at the intersections of all street types that contain an on-street parking lane adjacent to the curb, to support pedestrian safety. Curb extensions may contain landscaped bioretention cells to facilitate stormwater infiltration and meet the requirements of [Section 7.04.D.4 \(Stormwater Management Facilities\)](#).
6. Accessible Ramps and Warning Panels. Accessible ramps and warning panels are required where all sidewalks or trails terminate at a crosswalk or curb, per the Americans with Disabilities Act or any more stringent state requirement. Two ramps per corner at intersecting streets are required and must be oriented perpendicular to traffic.
7. Curbs and Gutters. The dimensions and materials of all curbs and gutters must be determined by the Zoning Officer in consultation with the Village Engineer.

D. Street Type Design Standards.

1. General Standards for Street Types. New streets within subdivisions will be configured as a street type that meets the requirements of [Table 7.04.1 General Standards for Street Types](#). The Zoning Officer, in consultation with the Village Engineer, may require modifications to the street type standards depending on the unique characteristics of the site.
 - a. Graphics. The graphics provided illustrate each street type and provide examples of potential configurations of that street type. Other configurations may be deemed acceptable by the Zoning Officer, in consultation with the Village Engineer.
 - b. Typical Street Elements. Typical street elements are part of either the vehicle realm or the pedestrian realm. Refer to [Figure 7.04.6 Typical Right-of-Way Elements](#).

Figure 7.04.6 Typical Right-of-Way Elements

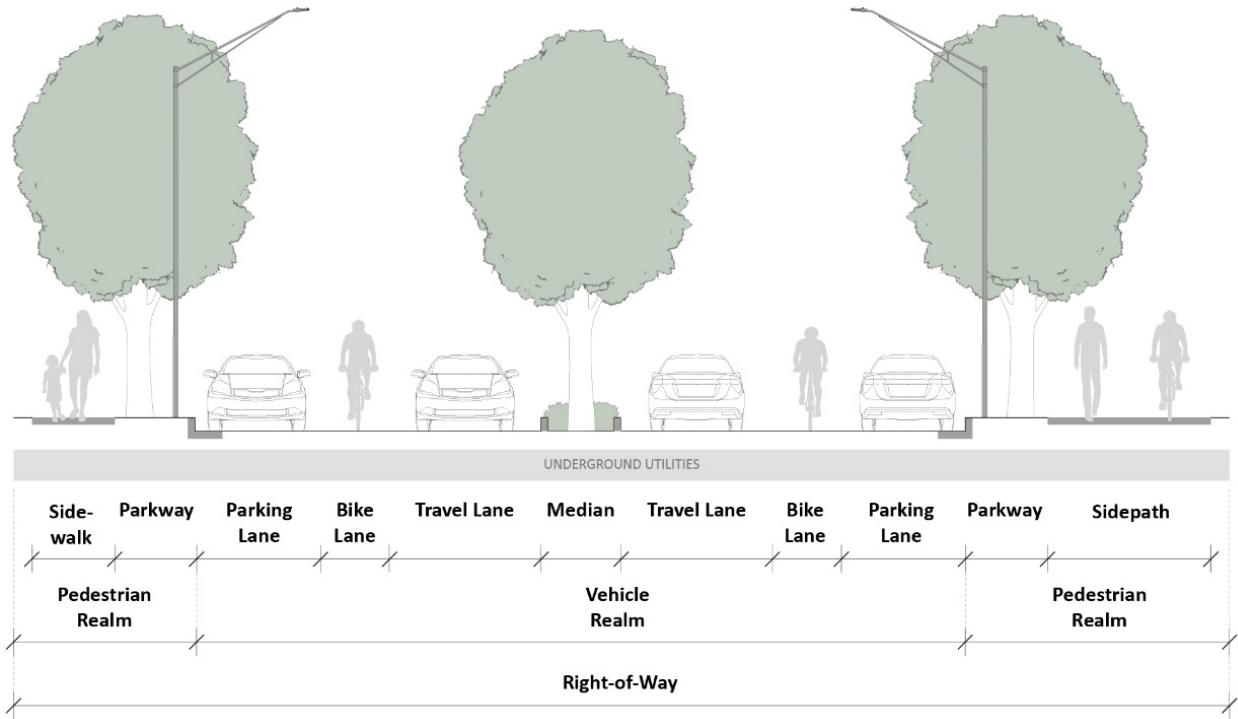
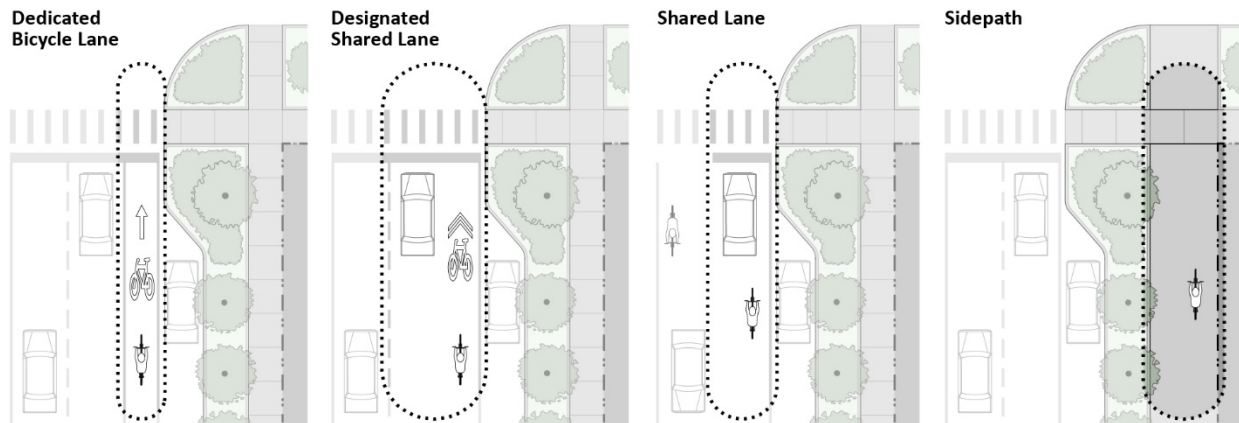

Table 7.04.1 General Standards for Street Types

Street Type	Right-of-Way Width	Vehicle Realm						Pedestrian Realm	
		Travel Lanes	Allowed Turn Lanes	Parking Lanes	Pavement Width (back of curb to back of curb)	Median	Bicycle Facilities	Pedestrian Facilities	Minimum Parkway
Arterial Street	90-120 ft	4	Left permitted with median; Right permitted in place of parking	Parallel parking lane optional on both sides	54-86 ft	Permitted, minimum 6 ft wide	Dedicated bike lanes or sidepaths	Minimum 10 ft sidepath or 5 ft sidewalk on both sides	8 ft both sides
Collector Street	80 ft	2	Left permitted; Right permitted in place of parking	Parallel parking lane optional on both sides	39-54 ft	Permitted, minimum 4 ft wide	Dedicated bike lanes, designated shared lanes, or sidepaths	5 ft sidewalk on both sides	8 ft both sides
Local Street	66-74 ft	2	Right permitted in place of parking	Parallel parking lane allowed on 1 side	Low Density: 28 ft High Density: 31 ft	Permitted, minimum 4 ft wide	Dedicated bike lanes or designated shared lanes	5 ft sidewalk on both sides	8 ft both sides
Alley	20-30 ft	1	Prohibited	Prohibited	20-30 ft	Prohibited	Shared lane	Shared	N/A

2. Bicycle Facilities. New streets must include on-street or off-street bicycle facilities. Three types of on-street bicycle facilities are permitted in the vehicle realm and one type of off-street bicycle facility is permitted in the pedestrian realm. Refer to [Figure 7.04.7 Bicycle Facilities](#).
 - a. Dedicated Bicycle Lane. Dedicated bicycle lanes are on-street striped lanes outside the outermost vehicular travel lanes. Dedicated bicycle lanes must be located on both sides of the street and must be a minimum of five feet wide.
 - b. Designated Shared Lane. Designated shared lanes are on-street lanes that are shared by vehicles and bicycles. Designated shared lanes must be a minimum of 14 feet wide to accommodate both vehicles and bicycles. On two-way streets, a designated shared lane is required in both directions. Designated shared lanes must be indicated by shared lane markings or sharrows.
 - c. Shared Lane. Shared lanes are on-street facilities that do not have dedicated bicycle lanes or designated shared lanes, but that allow bicycles to comfortably share lanes with vehicular traffic due to the speed and configuration of the street.
 - d. Sidepath. Sidepaths are off-street facilities that are shared by pedestrians and bicyclists. Sidepaths function like a sidewalk but are wide enough to accommodate pedestrians and bicyclists simultaneously. Sidepaths are required on both sides of the street and must be a minimum of 10 feet wide. At the Zoning Officer’s discretion, one sidepath may be located on only one side of the street provided the sidepath is a minimum of 12 feet wide.

Figure 7.04.7 Bicycle Facilities



3. Street Trees. Street trees must be installed in rights-of-way in accordance with [Section 11.04 \(Street Trees\)](#).
4. Stormwater Management Facilities. Stormwater management facilities approved by the Village may be integrated within the right-of-way of all street types to help clean and infiltrate stormwater runoff (refer to [Figure 7.04.8 Bioswale Design](#), [Figure 7.04.9 Bioretention Planter Design](#), and [Figure 7.04.10 Bioretention Curb Extension Design](#)).
 - a. Bioswales, bioretention planters, or other stormwater management best management practices are encouraged to be installed within all new parkways.
 - b. Bioretention cells may be included within curb extensions for all street types when a parking lane is adjacent to the parkway. Bioretention cells may extend into the parkway.

Figure 7.04.8 Bioswale Design

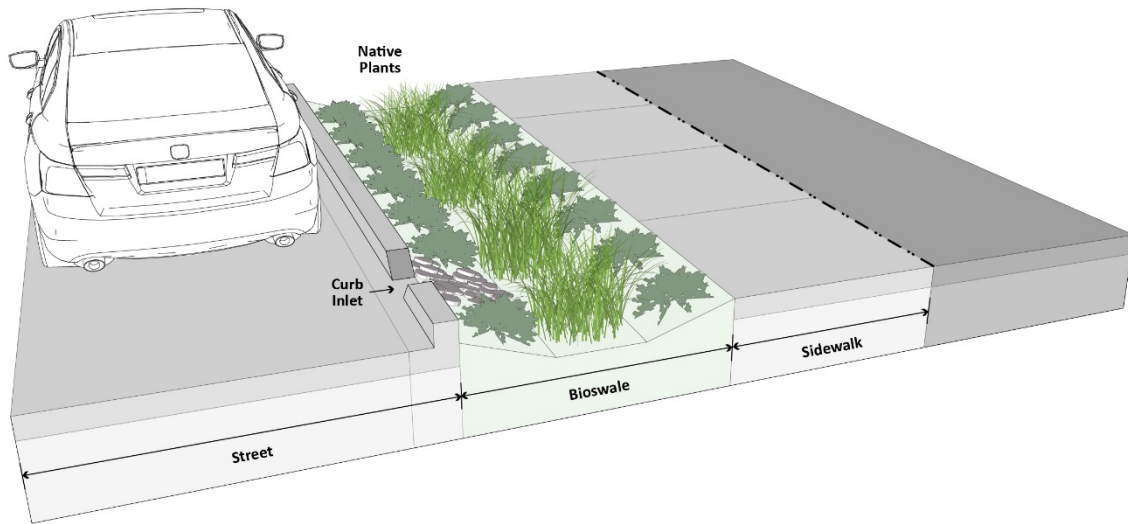

Figure 7.04.9 Bioretention Planter Design

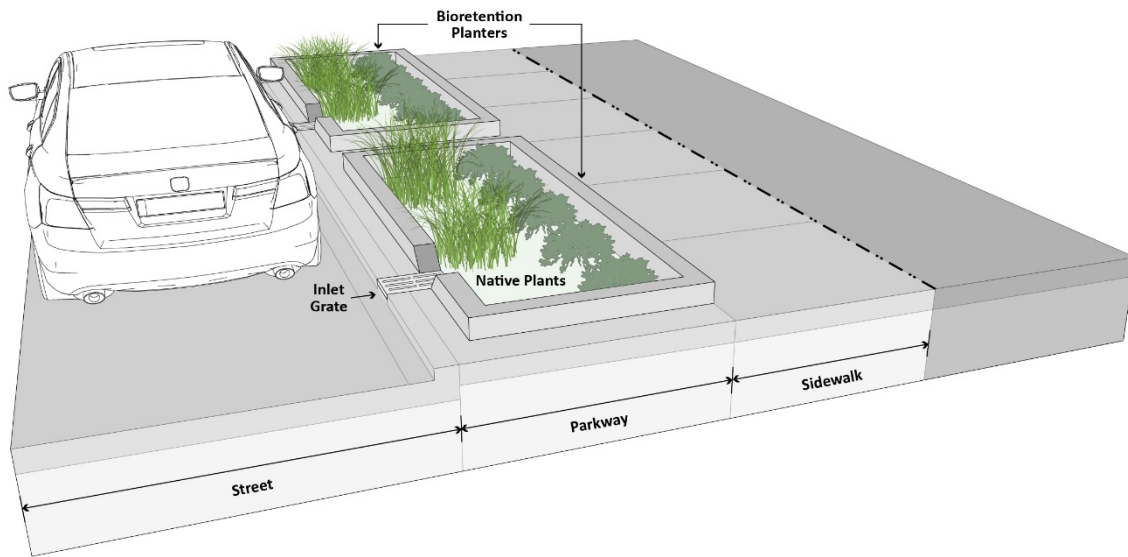
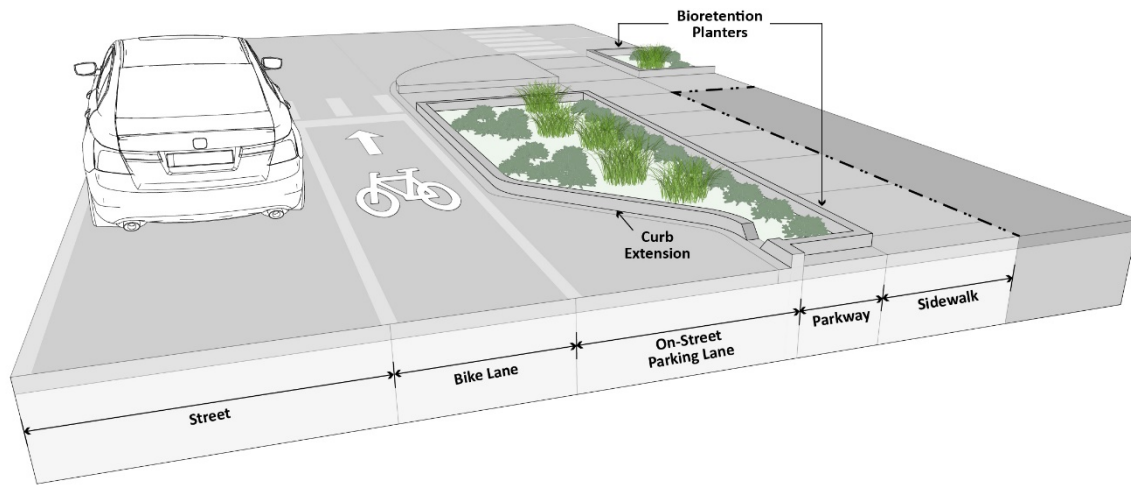

Figure 7.04.10 Bioretention Curb Extension Design



7.05 Required Public Improvements

- A. Applicability. Public improvements must be provided in accordance with this Section.
- B. Compliance Required. Before a final plat or planned unit development is approved, the Zoning Officer, in consultation with the Village Engineer, must certify that the improvements described in the applicant's plans, specifications, and agreements meet the minimum requirements of the Village. All construction work must be in accordance with the Montgomery Engineering Design and Inspection Policy Manual, unless otherwise specified.
- C. Construction Security.
 - 1. Amount. After approval of the final engineering documents, the property owner must submit a construction security to the Village Engineer to guarantee completion of public improvements. The amount of the construction security will be determined by the Zoning Officer in consultation with the Village Engineer so that it is sufficient to cover the cost of all public improvements required within the subdivision, but the amount will be at least 110 percent of the estimated final public improvement costs. The construction security must be made as a cash security deposit, letter of credit, bond with agreement for its disposition, or other form of surety approved by the Zoning Officer.
 - 2. Procedure.
 - a. Withdrawal of Funds. In the event that any public improvement is not properly constructed, completed, and transferred to the Village, the funds represented by the construction security or any portion thereof, may be withdrawn by the Village. The Village may withdraw funds from the construction security if material deterioration occurs, or if the public improvements present an imminent hazard to life or property.

- b. Insufficient Funds. In the event that there are insufficient funds for the construction security, the applicant is responsible to fund any costs described in this Section. The applicant must compensate the Village within 30 days of the notice of this deficiency.
 - c. Village Discretion. The standards of this Section must not be interpreted to require the Village to complete, maintain, or repair any public improvement which has not been accepted by the Village. It is expressly provided that the Village has the right, but not the obligation, to perform such work at its sole discretion.
 - d. Reduction of Security. Construction security may be reduced prior to acceptance of the public improvements by the Village Board, subject to the following:
 - (1) The applicant must provide a sworn statement attesting to the cost of the work performed, and estimating the cost to complete all remaining public improvements.
 - (2) The security reduction request must not exceed the cost of the work performed, as stated in the applicant's sworn statement.
 - (3) The applicant must provide written lien waivers for all labor and materials provided when public funds are involved.
 - (4) The security reduction request will not be approved if it would reduce the balance of the remaining security funds below 110 percent of the estimated cost of completing the remaining public improvements.
 - (5) The security reduction request must be accompanied by a certificate from the Village Engineer that confirms the applicant's compliance with this Section and recommends approval of the security reduction. The Village Engineer's certificate is not considered acceptance of any public improvements by the Village.
3. Liability of the Village. The Village is not liable for any damages that occur on any dedicated right-of-way within a new subdivision that has not been accepted by the Village. The applicant must indemnify, hold harmless, and defend the Village from any damage claims that may be asserted.

D. Acceptance of Subdivision Improvements.

- 1. Compliance. Inspection and acceptance of subdivision improvements must comply with the procedures of the Montgomery Engineering Design and Inspection Policy Manual.
- 2. Inspection of Subdivision Improvements.
 - a. Approval. All plans and specifications for required subdivision improvements must be approved by the Village Engineer and any designees. All subdivision improvements must be installed and accepted by the Village Board following approval of the final plat.
 - b. As-Built Plans. As-built plans must be submitted to the Village Engineer after construction is completed, but prior to the Village's acceptance of the public improvements. As-built plans must be reviewed for accuracy and approved by the Village Engineer. As-built plans must include all of the information required by the Montgomery Engineering and Inspection Policy Manual, including, but not limited to, water mains and bends, street lighting systems, manholes, storm sewers, sanitary sewers, stormwater best management practices, valves, service connections, and other similar facilities.
- 3. Acceptance of Subdivision Improvements.
 - a. Village Board Approval and Acceptance. The Village Board will approve and accept the subdivision improvements after the Village Engineer certifies that all required subdivision

improvements have been constructed and installed in accordance with the previously approved plans and specifications.

- b. Permanent Connections. The applicant must not make any permanent connections to any wastewater collection, water distribution, or street lighting systems until the Village Engineer has certified that the required improvements have been properly constructed and the applicant has paid all applicable fees.
- c. Partial Development Completion Required. The Village Board will not accept any rights-of-way or public improvements until certificates of occupancy have been issued for at least 75 percent of the platted lots in the development.

4. Deposit Required. No subdivision improvements will be accepted by the Village until the applicant provides a cash security deposit, letter of credit, or maintenance bond equal to 10 percent of the estimated cost of the improvements. This deposit guarantees satisfactory performance of the improvements constructed within the subdivision and the Village will hold the deposit for 12 months after accepting such improvements.

5. Refund of Deposit. After the end of this 12-month period, the cash security deposit will be refunded, or the letter of credit, or maintenance bond will be released if no defects have developed. If any defects have developed, then the applicant is responsible for repairing all such defects.

6. Performance Guarantee Release. The cash security deposit required by [Section 7.05.D.4 \(Deposit Required\)](#) will be posted with the Village upon approval of the construction of the improvements, and the performance guarantee will be released.

7. Snow, Ice, and Debris Removal. The developer is responsible for clearing snow, ice, and debris from all dedicated streets within the subdivision which have been improved but not yet accepted by the Village. If the developer fails to clear snow, ice, or debris from any such street within six hours of any snowfall or debris-causing event, this failure will be considered a violation of the provisions of this Section.

8. Improvement Conveyance. The developer must convey all completed improvements to the Village by a bill of sale in a form approved by the Village Attorney as a condition of acceptance of all required subdivision improvements.

9. Inspection at Developer's Expense. All public improvements proposed under the provisions of this Ordinance will be inspected during the course of construction by the Village Engineer or any designees. All fees and costs connected with such inspection must be paid by the applicant.

E. Water Supply.

1. Provision of Service. The developer must provide the development with a complete water main supply system that is connected to a public water supply system. The system must provide reliable and adequate water supply and must be constructed according to the specifications and performance standards established by the Village and any other agencies that have jurisdiction.

2. Water Mains.

- a. Construction Standards. All water mains and appurtenances must meet the requirements of the latest edition of the Standard Specifications for Water and Sewer Construction in Illinois.
- b. Minimum Diameter. Water mains must be at least eight inches in diameter, and include shutoff valves and fire hydrants.

3. Fire Hydrants.

- a. General Requirement. Fire hydrants must be installed per the current requirements of the fire district that has jurisdiction.
- b. Location. Fire hydrants must be installed throughout a development at least every 300 feet and take advantage of space adjacent to driveways, unless otherwise authorized by the fire district that has jurisdiction.

F. Sanitary Sewer.

1. Consistency. The sanitary sewer system shall be designed and constructed in accordance with the requirements of the Village, the Fox Metro Water Reclamation District, the Illinois Environmental Protection Agency (IEPA), and the current edition of the Standard Specifications for Water and Sewer Construction in Illinois.
2. Provision of Service. The developer must provide the development with a complete sanitary sewer system that is connected to a public sanitary sewer system.

G. Stormwater Drainage and Management.

1. Consistency. All development must comply with the Kane County Stormwater Management Ordinance and the landscape standard established in [Section 11 \(Landscape Standards\)](#), with the exception of modifications adopted by the Village.
2. Watercourse and Drainage Easements. For any development traversed by a water course, drainage-way, channel, or stream, a stormwater easement or drainage right-of-way must be provided that conforms substantially with the lines of such watercourse and the Kane County Stormwater Management Ordinance. Reference Kane County Stormwater Ordinance.

H. Communication, Power, and Other Utilities.

1. Location of Utility Lines. All communication, power, and other utility lines, including above ground enclosures, must be located in the interior side or rear yards. All communication, power, and other utility lines, except power lines carrying 12,000 volts or more, must be placed underground within easements in the rear yard of lots or dedicated public rights-of-way.
2. Compliance. The installation of such facilities must be made in compliance with the applicable regulations of the Illinois Commerce Commission. The owner or developer of any property served by underground installations is responsible for compliance with the applicable regulations of the [Illinois Public Utilities Act \(220 ILCS 5/1-101 et seq.\)](#)
3. Utility Clustering. Utility services should be clustered within a single easement when feasible.

- I. Street Construction. All new platted or dedicated streets must be improved with roadway paving in accordance with the Village of Montgomery Engineering Design and Inspection Policy Manual. Street construction may be subject to standards outside of this Ordinance, including the Illinois Department of Transportation (IDOT), the Manual on Uniform Traffic Control Devices (MUTCD), the American Association of State Highway and Transportation Officials (AASHTO), and the National Association of City Transportation Officials (NACTO).
- J. Street Lighting. Street lighting must be installed in accordance with the standards and specifications of the Village of Montgomery Engineering Design and Inspection Manual. Installed luminaires must include LED or similar energy efficient technology.
- K. Easements.
 - 1. Easement Provision. Easements must be provided for utility services and drainage including, but not limited to, water supply, sanitary sewer, storm sewer, stormwater, gas, telecommunication, cable television, and electric. Easements must be marked on the final plat and must be a minimum of 10 feet wide as measured for the combined width of the interior side yards. The location of the utility easement is determined by the developer and the appropriate utility company, and be approved by the Zoning Officer, in consultation with the Village Engineer.
 - 2. Authority to Access. The Village and utility companies have the authority to construct, operate, and maintain utility systems within easements, including access across property for necessary personnel and equipment.
 - 3. Building Limitations. Principal buildings and accessory structures are prohibited within easements. Easements may be used for sidewalks, driveways, and other purposes that do not interfere with the utility and its maintenance. The Village or utility may remove any structures or landscaping within the easement that interferes with the operation of the utilities, without compensation.
 - 4. Reserve Strips. Reserve strips that control access to public utilities, streets or alleys are prohibited.

7.06 Cash and Land Donations

- A. Applicability. The requirements of this Section apply to new subdivisions and new planned unit developments to provide for the Village's needs for various facilities and services, such as public schools, parks, street maintenance, and police and fire protection.
- B. Ultimate Population Per Dwelling Unit. The ultimate population density generated by a subdivision or planned unit development must use the projections set forth in [Table 7.06.2 Ultimate Population Per Dwelling Unit](#).

Table 7.06.2 Ultimate Population Per Dwelling Unit

Type of Dwelling	Pre-School 0-4 Years	Elementary Grades K-6 5-11 Years	Junior High Grades 7-8 12-13 Years	High School Grades 9-12 14-17 Years	Adults 18+ Years	Total Population Per Dwelling
Single-Unit Dwelling						
1-Bedroom	0.000	0.000	0.000	0.000	1.193	1.193
2-Bedroom	0.113	0.136	0.048	0.020	1.700	2.017
3-Bedroom	0.292	0.369	0.173	0.184	1.881	2.899
4-Bedroom	0.418	0.530	0.298	0.360	2.158	3.764
5-Bedroom	0.283	0.345	0.248	0.300	2.594	3.770
Two-Unit Dwelling and Townhouse Dwelling						
1-Bedroom	0.000	0.000	0.000	0.000	1.193	1.193
2-Bedroom	0.064	0.088	0.048	0.038	1.752	1.990
3-Bedroom	0.212	0.234	0.058	0.059	1.829	2.392
4-Bedroom	0.323	0.322	0.154	0.173	2.173	3.145
Multi-Unit Dwelling						
Studio	0.000	0.000	0.000	0.000	1.294	1.294
1-Bedroom	0.000	0.002	0.001	0.001	1.754	1.758
2-Bedroom	0.047	0.086	0.042	0.046	1.693	1.914
3-Bedroom	0.052	0.234	0.123	0.118	2.526	3.053

C. Park Site Donation.

1. General Provisions.

- a. Conveyance of Land. Required land donations must be provided per [Section 7.06.F \(Conveyance of Land Donation\)](#).
- b. Cash Donations. Required cash donations must be provided per [Section 7.06.G \(Cash Donations\)](#).
- c. Phasing. The improvement of all donated park land sites must be completed by the developer before 20 percent of the certificates of occupancy have been issued.

2. Land Donation Calculation.

- a. Park Acreage Requirement. The amount of park land required is determined by the ultimate density of the proposed development. For parks, 10 acres of park land per 1,000 residents must be donated.
- b. Land Donation Formula. The amount of park land to be donated is determined by the following formula. The total number of units for each dwelling type to be built is multiplied by the corresponding population density in [Table 7.06.2 Ultimate Population Per Dwelling Unit](#). The product for each dwelling type is added to calculate the ultimate population of the

development. The ultimate population for all dwelling units is then divided by 1,000. The result of such division is then multiplied by 10 to determine total acreage needed for park land donation.

3. Criteria for Required Park Land Donation.

- a. General Uses. The park land donation site must be suitable for the purposes for which it is intended, and must be an integral component of the neighborhood, rather than left over parcels. The required park land donations must be used for play lots, mini parks, neighborhood parks, and community parks in accordance with [Table 7.06.3 Types of Parks](#).

Table 7.06.3 Types of Parks

Type	Size Range	Minimum Acres Per 1,000 People
Play Lots and Mini Parks	0.25 - 1.5 acres	1.0
Neighborhood Parks	3.0 - 10.0 acres	4.0
Community Parks	15.0 acres or more	5.0

- b. Location.

- (1) Parks must be located at least 1,320 feet from every lot in the subdivision, as measured by walking distance, so they are accessible to the surrounding neighborhood.
- (2) The slope, topography, and geology of the donated site must be suitable for use as a park.
- (3) The Village retains final selection and approval authority for all park site locations.

- c. Compatibility with Current Plans. The Village’s Comprehensive Plan and its other land use policies will guide the location of park sites. Land donation will only be accepted in instances where a developer owns land in reasonable proximity to a planned park site. In all other cases, the payment of fees in lieu of actual land is required.

- d. Condition of Donated Land. Donated land must be in a condition ready for facility development including proper site drainage and curb and gutter treatment in a manner consistent with the rest of the development. Original topsoil and vegetative cover must either remain undisturbed or the site must be prepared in a manner consistent with the standards of the applicable park district.

4. Park Land Donation Substitutions.

- a. Fee In Lieu. If it is determined that park land would be more appropriately located off-site, per the requirements of [Section 7.06.G \(Cash Donations\)](#), the Village may agree to accept cash in lieu of land.
- b. Off-Site Park Land Donations. Off-site park land may meet a maximum of 50 percent of the total required park land donation provided that such land is accessible to the community, and advances Village goals to naturalize flood-prone properties, transition to passive recreation use, or increase conservation areas.
- c. Park Improvements Credit. The Village Board may recognize existing or proposed park improvements as equal to or greater than the value of the improvement fees required in this Section and may credit the development’s total required park contribution with the value of such site improvements.
- d. Private Parks. Private parks may meet a maximum of up to 25 percent of the total park land donation, provided that such land is determined to be of equivalent value to public park land and that the park is available by right to all residents of the development.

D. School Site Donation.

1. General Provisions.

- a. Conveyance of Land. Required land donations must be provided per [Section 7.06.F \(Conveyance of Land Donations\)](#).
- b. Cash Donations. Required cash donations must be provided per [Section 7.06.G \(Cash Donations\)](#).

2. School Land Donation Calculation.

- a. School Classifications and Size of School Site. School classifications and the size of school sites within the Village must be determined in accordance with the criteria shown in [Table 7.06.4 School Classifications and Size](#). The criteria provided is consistent with the Illinois Office of Education Standards, as adopted by the Illinois State Board of Education.
- b. Land Donation Formula. The ultimate number of students generated by a subdivision or planned unit development have a direct impact on the amount of land required for school sites. The following formula determines how many acres are required to be donated.
 - (1) The total number of units for each dwelling type to be built is multiplied by the corresponding population density in [Table 7.06.2 Ultimate Population Per Dwelling Unit](#).
 - (2) Use the resulting projections for students and [Table 7.06.4 School Classifications and Size](#) to establish the ratio of projected students to the required acreage for school sites for each school classification.

Table 7.06.4 School Classifications and Size

Type	Maximum Number of Students	Minimum Acres of Land
Elementary schools, grades K-5	600	11
Middle schools, grades 6-8	1,000	29
High schools, grades 9-12	2,500	55

E. Reservation of Additional Land for Parks and Schools. In situations where the Village’s Comprehensive Plan and the other land use policies of the Village call for a larger park or school site than the amount calculated by the requirements of this Section, the land needed must be reserved for purchase by the Village or other public body designated by the Village. The purchase will be set at the average fair market value of the land, as determined by the Village, provided that the agreement for land acquisition is made within one year of final plat approval. The failure of the Village or other public body to reach an agreement for land acquisition within one year of final plat approval will terminate the reservation and release said property for future development in accordance with this Ordinance.

F. Conveyance of Land Donation.

- 1. Title. All land donations for park, school or other public purpose must be conveyed to the Village, school district, or other public body following the recording of a final plat or approval of a planned unit development agreement.
- 2. Conveyance Requirements. Each deed or other instrument conveying land must be accompanied by:

- a. A written commitment issued by a title insurer licensed to do business in Illinois to insure the title to such real estate in an amount equal to its value. The written commitment will be subject to current real estate taxes, covenants, conditions, and restrictions.
 - b. A current boundary line survey, certified to the Village by a licensed Illinois Land Surveyor.
 - c. An assessment plat and tax division petition in a form acceptable to the appropriate county authorities so that the land can be assigned its own property index number.
 - d. An environmental audit prepared by an environmental consultant acceptable to the Village, assuring the Village that there are no hazardous or toxic substances on the property as defined in federal, state or local laws.
3. Maintenance. Maintenance of the land reserved for a park, school, or other public purpose is the responsibility of the developer of the property from the date that it is conveyed until ownership is transferred or the property is sold. Failure of the developer to maintain the property will result in relinquishing all rights to the property, subject to statutory law governing conveyances of municipal real estate.

G. Cash Donations.

- 1. Establishment of Fees.
 - a. Determination of In-Lieu Fee Amounts. The cash contribution in lieu of land is determined by multiplying the acreage demand for a given development by the average fair market value for land acquisition.
 - b. Determination of Fair Market Value. The cash contributions in lieu of land is based on the fair market value of subdivided land that otherwise would have been donated as park or school sites. The average fair market value for acquiring improved land in the Village is \$90,000 per acre as of March 8, 2021. The fair market value will be adjusted upward at an annual rate of 3 percent.
- 2. Criteria for Requiring a Contribution in Lieu of Park or School Sites.
 - a. Unsuitability Determination. The determination that available land is unsuitable for a park or school site must be made by the Village after inspecting the land and receiving the recommendation of the local school board and the developer affected.
 - b. Small or Otherwise Inappropriate Sites. In cases where a development is small and the resulting site would be inappropriate for a park or school, the Village will require the developer to pay a cash contribution in lieu of land donation.
- 3. Donation of Both Land and Cash In Lieu of Land. Situations where a required donation of both land and cash in lieu of land will be determined by the Village as follows.
 - a. A portion of the land to be developed is proposed as the location for a park or school site. The portion of the land within the subdivision that is within the park or school site must be donated as an appropriate site and a cash contribution is required in lieu of any additional land that is required.
 - b. A part of the designated park or school site has already been acquired and only a small portion of land is needed from the development to complete the site. The remaining portion is required by donation, and a cash contribution in lieu of the land is required.
 - c. A certain park or school site will be donated, and the rest of the required park or school site acreage would be unsuitable for a park or school. In this case, the cash must be contributed in lieu of the rest of the required school or park site acreage.

4. Time and Manner of Payment. Payments covering fees in lieu and initial improvement fees will be determined by the Village at the time of final plat or planned unit development approval.
5. Cash Donations for Special Districts.
 - a. Deposit and Distribution. Cash contributions for non-Village services must be deposited with the Village and subsequently distributed to special districts upon written request by the applicable district. The amount of the contribution will be determined by the Village in consultation with the district. The funds must be used by the district in which the funds were collected to improve facilities, equipment, or operations.
 - b. Indemnification. By accepting land and/or cash, the special district must indemnify the Village in writing against any loss, cost, or expense designated for the district.
 - c. Reimbursement. By accepting land and/or cash, the special district must reimburse the Village for all expenses incurred in obtaining the land and/or cash required by this Section. The payment must be made to the Village within 30 days of the district's receipt of the land and/or cash, or receipt of an invoice from the Village, whichever occurs later.

SECTION 8: ZONING DISTRICT REGULATIONS

- [8.01 Purpose](#)
- [8.02 Applicability](#)
- [8.03 Development Standards of General Applicability](#)
- [8.04 Zoning Map](#)
- [8.05 Use of Land and Buildings](#)
- [8.06 Establishment of Zoning Districts and Purpose Statements](#)
- [8.07 Summary Table of Zoning Requirements](#)
- [8.08 FO Floodplain Overlay District](#)
- [8.09 A Agricultural District](#)
- [8.10 Design Requirements for Residential Zoning Districts](#)
- [8.11 R-1 Single-Unit Dwelling District](#)
- [8.12 R-2 Single-Unit Dwelling District](#)
- [8.13 R-3 Single-Unit Dwelling District](#)
- [8.14 R-4 Attached Single-Unit Dwelling District](#)
- [8.15 R-5 Multiple-Unit Dwelling District](#)
- [8.16 Design Requirements for Business Zoning Districts](#)
- [8.17 MD Mill District](#)
- [8.18 B-1 Neighborhood Business District](#)
- [8.19 B-2 Regional Business District](#)
- [8.20 Design Requirements for Manufacturing Zoning Districts](#)
- [8.21 M-1 Light Manufacturing District](#)
- [8.22 M-2 General Manufacturing District](#)

8.01 Purpose

The purpose of this Section is to establish the development standards for properties within the Village.

8.02 Applicability

The provisions of this Section apply to all new construction and significant exterior renovation of existing structures. Refer to Section 6 (Nonconformities) for information on the continuation of nonconforming structures.

8.03 Development Standards of General Applicability

The following sections provide development requirements that must be met in addition to the development requirements established in this Section.

- A. Site Plan Review. [See Section 4.02 \(Site Plan Review\)](#) for applicable site plan review requirements.
- B. Uses. See [Section 9 \(Uses\)](#) for principal, accessory, and temporary use requirements as well as standards for accessory and temporary structure requirements.
- C. Parking and Loading. See [Section 10 \(Off-Street Parking and Loading\)](#) for off-street parking, loading, and access requirements.

- D. Landscaping and Buffering. See [Section 11 \(Landscape Standards\)](#) for landscaping, buffering, and screening requirements.
- E. Signs. See [Section 12 \(Signs\)](#) for sign requirements.
- F. Building Regulations. Refer to [Chapter 6 \(Buildings and Construction\) of the Municipal Code](#) for additional development requirements outside the purview of this Ordinance.

8.04 Zoning Map

- A. Establishment of Zoning Map. The location and boundaries of the districts established in this Section are hereby established on the map designated as the Zoning Map of the Village of Montgomery and referred to herein as the “Zoning Map.” The Zoning Map is adopted by reference and declared to be part of this Ordinance.
- B. Map for Reference. The Zoning Map is kept for reference on the Village’s public website and in the offices of both the Village Clerk and the Zoning Officer.
- C. Zoning Map Amendments. All amendments to this Ordinance ([see Section 4.06 \(Zoning Text or Map Amendment\)](#)) that involve a change to the designation of a lot within a zoning district must be recorded on the Village’s official Zoning Map.
- D. Interpretation of Boundary Lines. The boundaries of all zoning districts shown on the Zoning Map are determined in accordance with the following:
 - 1. Right-of-Way Lines. Where zoning district boundary lines coincide with streets, alleys, railroads, easements, or similar rights-of-way, the centerline of the right-of-way is considered the boundary line of the district.
 - 2. Lot Lines. Where zoning district boundary lines coincide with a lot line, the lot line is considered the boundary line of the district.

8.05 Use of Land and Buildings

- A. Number of Buildings on a Lot. No more than one principal building may be located on a lot used for a single-unit or two-unit dwelling. For other uses, more than one principal building may be located on a lot provided that each building complies with the applicable requirements of this Section as though it were an individual principal building on a lot.
- B. Applicability of Regulations.
 - 1. Applicability of Use Regulations. No building, structure, or land may be used for any use other than a use allowed as either a permitted or special use in the zoning district in which such building, structure, or land is located. Buildings, structures, or land may also be used for an accessory use or a temporary use in accordance with the requirements of [Section 9.03 \(Accessory Structures and Uses\)](#) and [Section 9.04 \(Temporary Uses and Structures\)](#).
 - 2. Applicability of Lot and Setback Regulations. No lot or setback may be reduced below the minimum requirements of this Ordinance. Lots or setbacks created after the effective date of this

Ordinance must meet the minimum requirements for the zoning district in which the structure is located. All setbacks allocated to a building must be located on the same zoning lot as such building.

3. Applicability of Bulk and Height Regulations. All structures erected after the effective date of this Ordinance must meet the bulk and height requirements for the zoning district in which the structure is located. No existing structure may be enlarged, altered, reconstructed, or relocated in such a manner that conflicts with the requirements of the zoning district in which the structure is located.

C. Visibility Obstruction. Nothing may be erected, placed, or allowed to grow in a manner that will create a visibility obstruction for motorists, bicyclists, or pedestrians. No building, structure, sign, or landscape element may obstruct the area between 2.5 feet and eight feet in height within the sight triangle area. In the MD District, the sight triangle area is measured along 30 feet of curb line from the point where two or more streets intersect or where a street intersects railroad tracks. In zoning districts other than the MD District, the sight triangle area is measured along 30 feet of lot line in locations where two or more streets intersect. (See [Figure 8.05.1 Visibility Obstruction](#))

Figure 8.05.1 Visibility Obstruction
MD District

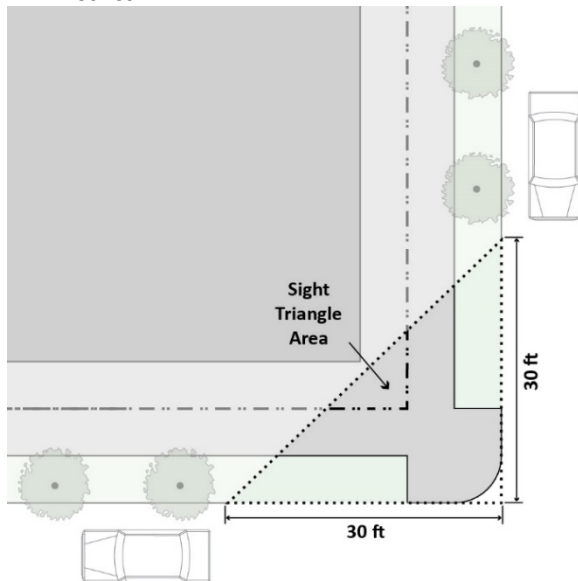

All Other Districts

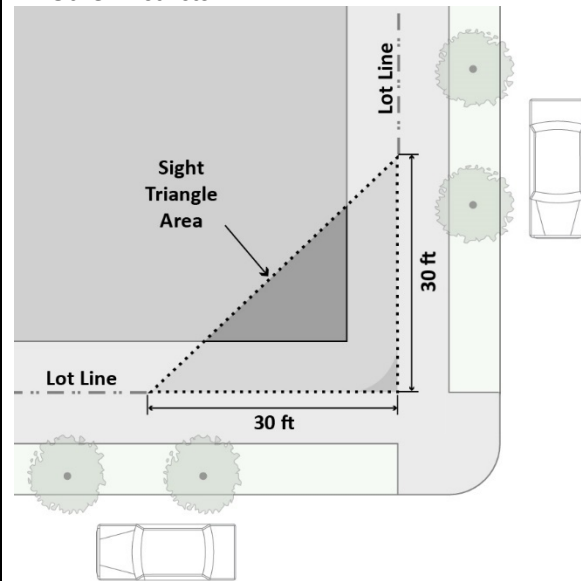

8.06 Establishment of Zoning Districts and Purpose Statements

In order to carry out the purpose and intent of this Ordinance, the Village is hereby divided into zoning districts with the following purpose statements.

- A. FO Floodplain Overlay District. The FO Floodplain Overlay District is established to protect the public health, mitigate the potential for property damage, and reduce the potential financial burden to areas subject to periodic flooding or with high water tables.
- B. A Agricultural District. The A Agricultural District is established to accommodate agricultural uses and limited non-agricultural uses that are compatible with agricultural development.
- C. Residential Districts.
 - 1. R-1 Single-Unit Dwelling District. The R-1 Single-Unit Dwelling District is established to accommodate low-density single-unit dwelling development in a manner consistent with existing neighborhoods of single-unit dwellings in the Village. The R-1 District allows single-unit dwellings and limited residential and non-residential uses that are compatible with surrounding residential neighborhoods.
 - 2. R-2 Single-Unit Dwelling District. The R-2 Single-Unit Dwelling District is established to accommodate moderate density single-unit dwelling development in a manner consistent with existing neighborhoods of single-unit dwellings in the Village. The R-2 District allows single-unit dwellings and limited residential and non-residential uses that are compatible with surrounding residential neighborhoods.
 - 3. R-3 Single-Unit Dwelling District. The R-3 Single-Unit Dwelling District is established to accommodate high density single-unit dwelling development in a manner consistent with traditional neighborhood design. The R-3 District allows single-unit dwellings and limited residential and non-residential uses that are compatible with surrounding residential neighborhoods.
 - 4. R-4 Attached Single-Unit Dwelling District. The R-4 Attached Single-Unit Dwelling District is established to accommodate two-unit dwellings and townhouse dwellings in a manner consistent with existing neighborhoods of two-unit dwellings and townhouse dwellings in the Village. The R-4 District allows two-unit dwellings and townhouse dwellings and limited residential and non-residential uses that are compatible with surrounding residential neighborhoods.
 - 5. R-5 Multiple-Unit Dwelling District. The R-5 Multiple-Unit Dwelling District is established to accommodate multiple-unit dwelling development in a manner consistent with existing neighborhoods of multiple-unit dwellings in the Village. The R-5 District allows multiple-unit dwellings and limited residential and non-residential uses that are compatible with surrounding residential neighborhoods.

D. Business Districts.

1. MD Mill District. The MD Mill District is established to accommodate pedestrian-oriented development that serves the Village and surrounding communities. The MD District allows a wide range of commercial, residential, and institutional uses within Downtown Montgomery.
2. B-1 Neighborhood Business District. The B-1 Neighborhood Business District is established to accommodate pedestrian and auto-oriented development that serves surrounding neighborhoods and surrounding communities. The B-1 allows a narrowly defined set of commercial and institutional uses primarily along local roads.
3. B-2 Regional Business District. The B-2 Regional Business Districts is established to accommodate auto-oriented commercial development that serves the Village and surrounding communities. The B-2 District allows a wide range of commercial and institutional uses primarily along major arterials, such as US Route 30, US Route 34, and Orchard Road.

E. Manufacturing Districts.

1. M-1 Light Manufacturing District. The M-1 Light Manufacturing District is established to accommodate low intensity manufacturing development with minimal impacts on neighboring properties. The M-1 District allows a narrowly defined set of light manufacturing, office, and research uses.
2. M-2 General Manufacturing District. The M-2 General Manufacturing District is established to accommodate high intensity manufacturing development with the potential for impacts on neighboring properties. The M-2 District allows a wide array of manufacturing uses.

8.07 Summary Table of Zoning Requirements

[Table 8.07.1 Summary Table of Zoning District Requirements](#) provides a summary of the bulk and setback requirements for each zoning district established in this Section. [Table 8.07.1](#) does not include a summary of the requirements for the FO Floodplain Overlay District.

Table 8.07.1 Summary Table of Zoning District Requirements

	A	R-1	R-2	R-3	R-4	R-5	MD	B-1	B-2	M-1	M-2
Bulk Requirements											
Minimum Lot Area	40 acres	9,000 sf	7,200 sf	5,500 sf	9,000 sf	20,000 sf	N/A	N/A	N/A	N/A	N/A
Minimum Lot Width	250 ft	75 ft	60 ft	45 ft	75 ft	100 ft	50 ft	50 ft	50 ft	100 ft	100 ft
Maximum Principal Building Height	35 ft	2.5 stories and 35 ft	2.5 stories and 35 ft	2.5 stories and 35 ft	2.5 stories and 35 ft	4 stories and 60 ft	4 stories and 56 ft	4 stories and 56 ft	4 stories and 56 ft	65 ft	100 ft
Maximum Primary Impervious Coverage	N/A	40%	45%	55%	60%	65%	N/A	N/A	N/A	N/A	N/A
Maximum Total Impervious Coverage	5%	50%	55%	65%	70%	75%	80% ⁴	90%	75%	80%	80%
Setback Requirements											
Minimum Front Setback	50 ft	30 ft	25 ft	15 ft	25 ft	25 ft	N/A	N/A	N/A	25 ft	25 ft
Maximum Front Setback	N/A	N/A	N/A	N/A	N/A	N/A	10 ft	75 ft	N/A	N/A	N/A
Minimum Corner Side Setback	50 ft	20 ft	15 ft	10 ft	10 ft	25 ft	N/A	N/A	N/A	25 ft	25 ft
Maximum Corner Side Setback	N/A	N/A	N/A	N/A	N/A	N/A	10 ft	75 ft	75 ft	N/A	N/A
Minimum Interior Side Setback	50 ft	12 ft	6 ft	5 ft	10 ft	20 ft	N/A	5 ft	10 ft	10 ft	10 ft
Minimum Rear Setback	100 ft	30 ft	30 ft	20 ft	30 ft	30 ft	N/A	20 ft	20 ft	20 ft	20 ft
Minimum Setback Adjacent to a Residential District	N/A	N/A	N/A	N/A	N/A	N/A	10 ft	20 ft	20 ft	30 ft	30 ft

⁴ In the MD District, a lot may have minimum additional semi-pervious coverage of 20%.

8.08 FO Floodplain Overlay District

A. Applicability.

1. Location. The requirements of the FO Floodplain Overlay District apply to all areas of the 100-year floodplain located within the Village that are identified by the Federal Emergency Management Agency (FEMA) as flood areas at high risk of flooding as shown on Flood Insurance Rate Maps (FIRMs). The FIRMs are adopted by reference and declared to be part of this Ordinance. The FIRMs are on file at the Village. The FO District includes the following areas:
 - a. Floodway. Areas of the 100-year floodplain that are designated as a floodway on FIRMs.
 - b. Flood Fringe. Areas of the 100-year floodplain that are located outside of the floodway on FIRMs.
2. Lots Within Floodplain. If a lot is located either partially or totally within the 100-year floodplain, the requirements of the FO District apply to the entire lot.
3. Relationship to Other Regulations. The requirements of the FO District do not limit the permitting requirements of the Illinois Department of Natural Resources Office of Water Resources (IDNR OWR) for floodplains, or the requirements of the Kane County Stormwater Management Ordinance. However, where the FO District imposes more restrictive standards, the more restrictive standards apply. The standards of the FO District do not require approvals from IDNR OWR in situations covered by the statewide floodplain construction permitting program.

B. General Requirements.

1. Base Flood Height Increases. No development is allowed in floodplain areas which will increase base flood height by 0.01 foot or more due to obstructing the flow of floodwaters, by itself or with other development, or due to the loss of floodplain storage area.
2. Required Setback. A minimum setback of 50 feet must be maintained from any waterbody or wetland, as measured from the shoreline, to prevent flooding and erosion from affecting structures.
 - a. No principal or accessory structures may encroach within the required setback area.
 - b. Required setback areas must be comprised of tree and plant species native or naturalized to northeastern Illinois in accordance with [Section 11.03.A.4 \(Species Diversity\)](#).
 - c. Pedestrian or bicycle paths, recreational access, utility access, and wayfinding and educational signs may be allowed within the required setback, with Floodplain Development Permit approval (see [Section 4.08 \(Floodplain Development Permit\)](#)).

C. Development Standards in Floodway. Development is allowed in the floodway upon approval of a Floodplain Development Permit (see [Section 4.08 \(Floodplain Development Permit\)](#)), subject to the standards of the underlying zoning district and the standards of [Section 8.08 \(FO Floodplain Overlay District\)](#). The following uses are permitted in the floodway; any use not listed is prohibited.

1. Open space.
2. Community garden.
3. Park.

4. Pedestrian or bicycle path.
 5. Other uses as may be approved by the Illinois Department of Natural Resources (IDNR)).
- D. Development Standards in Flood Fringe. Development is allowed in the flood fringe upon approval of a Floodplain Development Permit (see [Section 4.08 \(Floodplain Development Permit\)](#)), subject to the standards of the underlying zoning district and the standards of [Section 8.08 \(FO Floodplain Overlay District\)](#).
1. Uses Allowed in Flood Fringe. Any use, building, or structure allowed as a permitted or special use in the underlying zoning district is permitted in the flood fringe and structures allowed per the Kane County Stormwater Management Ordinance.
 2. Floodproofing Required. Any use, building, or structure located in the flood fringe must be designed to withstand flooding impacts associated with the base flood. Floodproofing measures must be certified by a registered professional engineer or architect. Floodproofing measures must be designed to:
 - a. Withstand floor pressures, depths, velocities, forces, and other base flood factors.
 - b. Protect structures to the flood protection elevation.
 - c. Anchor structures to foundations to resist flotation and lateral movement.
 - d. Ensure that structural walls and floors are watertight to the flood protection elevation to ensure that the interior remains completely dry during flooding.
 - e. Place essential utilities above the flood protection elevation.
 - f. Examples of floodproofing measures include, but are not be limited to, the following:
 - (1) Installing watertight doors, bulkheads and shutters.
 - (2) Reinforcing walls and floors to resist damage caused by water pressure or floating debris.
 - (3) Using paints, membranes, or mortars to reduce water seepage through walls.
 - (4) Adding mass or weight to structures to prevent flotation.
 - (5) Installing pumping facilities or subsurface drainage systems to lower water levels.
 - (6) Constructing water supply wells and waste treatment systems to prevent the entry of flood waters.
 - (7) Installing cutoff valves on sewer lines or eliminating gravity basement drains.

8.09 A Agricultural District

Table 8.09.1 A District Requirements, Figure 8.09.1 A District Requirements: Plan View, and Figure 8.09.2 A District Requirements: 3-D View establish bulk and setback regulations for the A District. See Section 9.03 (Accessory Structures and Uses) for provisions related to accessory structures.

Table 8.09.1 A District Requirements

Bulk Requirements		
	Minimum Lot Area	40 acres
A	Minimum Lot Width	250 ft
B	Maximum Principal Building Height	35 ft
	Maximum impervious Coverage	5%
Setback Requirements		
C	Minimum Front Setback	50 ft
D	Minimum Corner Side Setback	50 ft
E	Minimum Interior Side Setback	50 ft
F	Minimum Rear Setback	100 ft

Figure 8.09.1 A District Requirements: Plan View

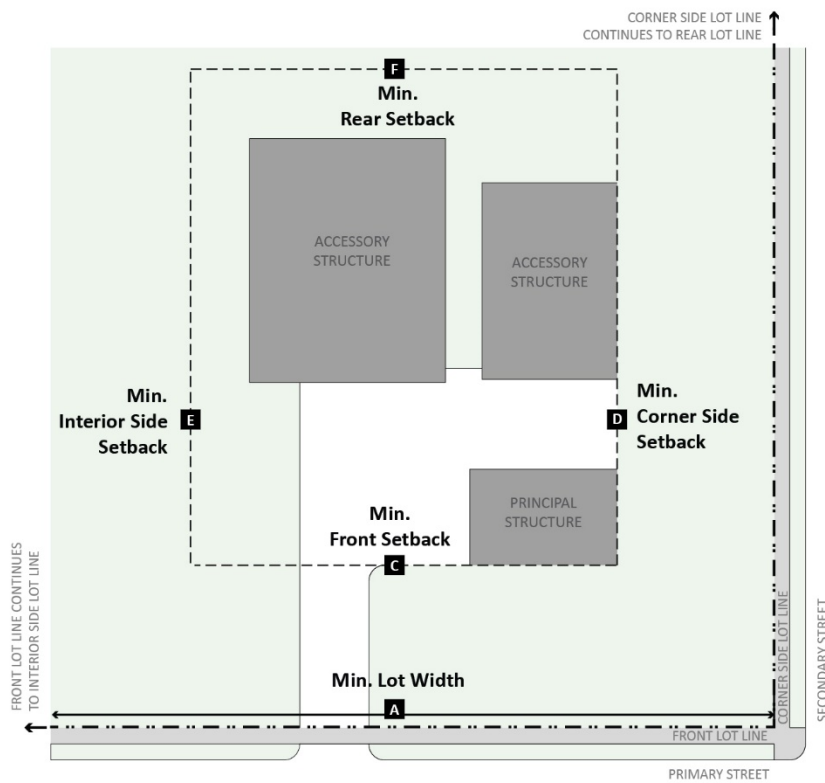
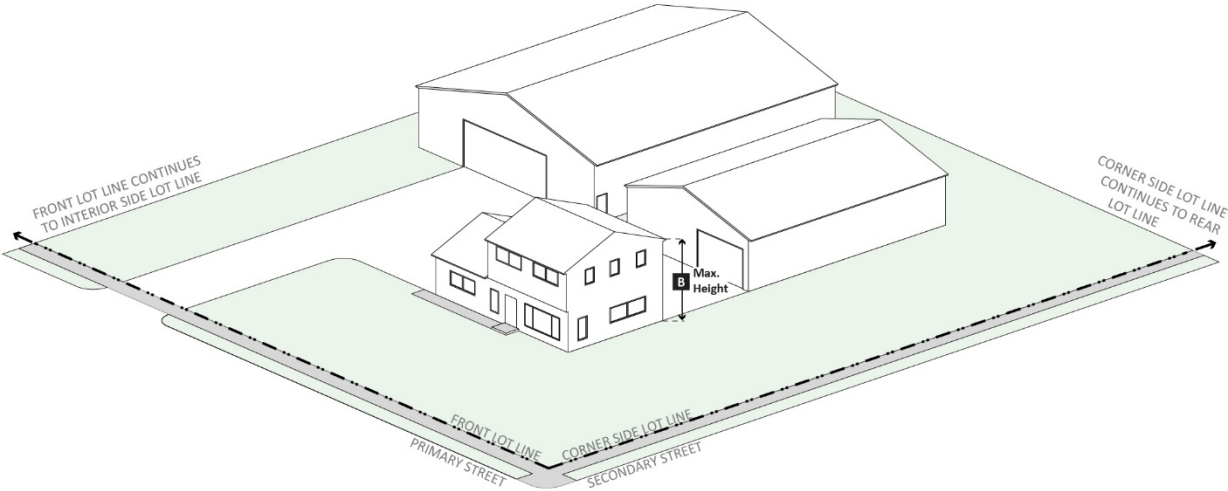

Figure 8.09.2 A District Requirements: 3-D View



8.10 Design Requirements for Residential Zoning Districts

- A. Applicability. The design requirements in this section apply to all new construction and additions to single-unit dwellings, two-unit dwellings, townhouse dwelling units, and multiple-unit dwellings within the Village's residential zoning districts.
- B. Design Requirements for Single-Unit Dwellings and Two-Unit Dwellings. Refer to [Figure 8.10.1 Single-Unit Dwelling and Two-Unit Dwelling Design Requirements](#) and [Figure 8.10.2 Anti-Monotony Façade Separation](#).
1. Façade Articulation. To avoid the appearance of blank walls on single-unit and two-unit dwellings, facades facing the front yard and corner side yard must include façade articulation, such as entrances, bay windows, porches, or other architectural features.
 2. Façade Transparency. At least one (1) window is required on facades facing the front yard, corner side yard, interior side yard, and rear yard. Minimum transparency of 15% is required on facades facing the front yard and corner side yard. Minimum transparency of 10% is required on facades facing the interior side and rear yard.
 3. Building Orientation for Corner Lots and Reverse Corner Lots. Single-unit and two-unit dwellings located on corner lots and reverse corner lots must have a relationship with the primary and secondary street to maintain the existing street wall on both streets to the greatest extent possible.
 4. Additions. Additions to single-unit and two-unit dwellings must maintain the architectural style, scale, and building mass of the existing structure. The exterior building materials, colors, trim, and other architectural details of the addition must complement the existing structure. All additions must meet the requirements of [Section 8.10.B \(Design Requirements of Single-Unit Dwellings and Two-Unit Dwellings\)](#).
 5. Roofs. Sloped roofs must include eaves of at least six inches in width.
 6. Anti-Monotony. New construction of single-unit and two-unit dwellings involving four or more lots must have distinctive façade designs. Single-unit and two-unit dwellings with similar façade designs must be separated by two or more lots on both side of the street. Single-unit and two-unit dwellings are considered distinct if they are different according to four of the following features.
 - a. Number of stories.
 - b. Architectural style, such as craftsman, prairie, or ranch.
 - c. Shape and dimensions of the front façade.
 - d. Color palettes and materials for walls, trim, and roofs.
 - e. Placement, size and style of doors and windows.
 - f. Roofline, roof pitch, and the number and location of dormers.
 - g. Location and proportion of front porches.
 - h. Location and proportion of garages and garage doors, if included on the front façade.

Figure 8.10.1 Single-Unit Dwelling and Two-Unit Dwelling Design Requirements

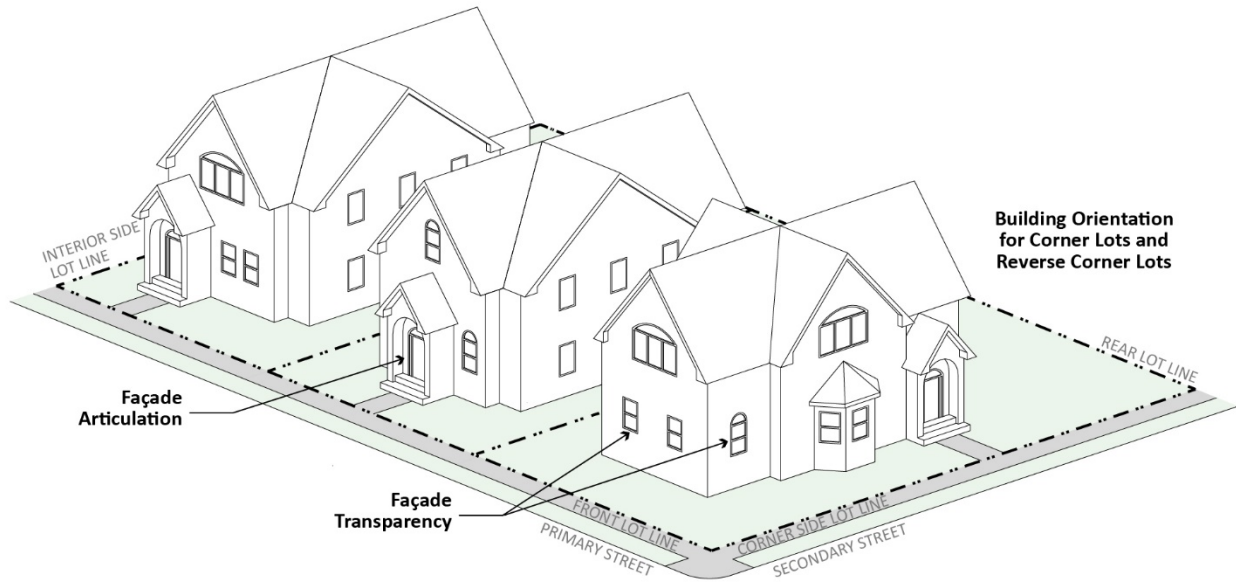
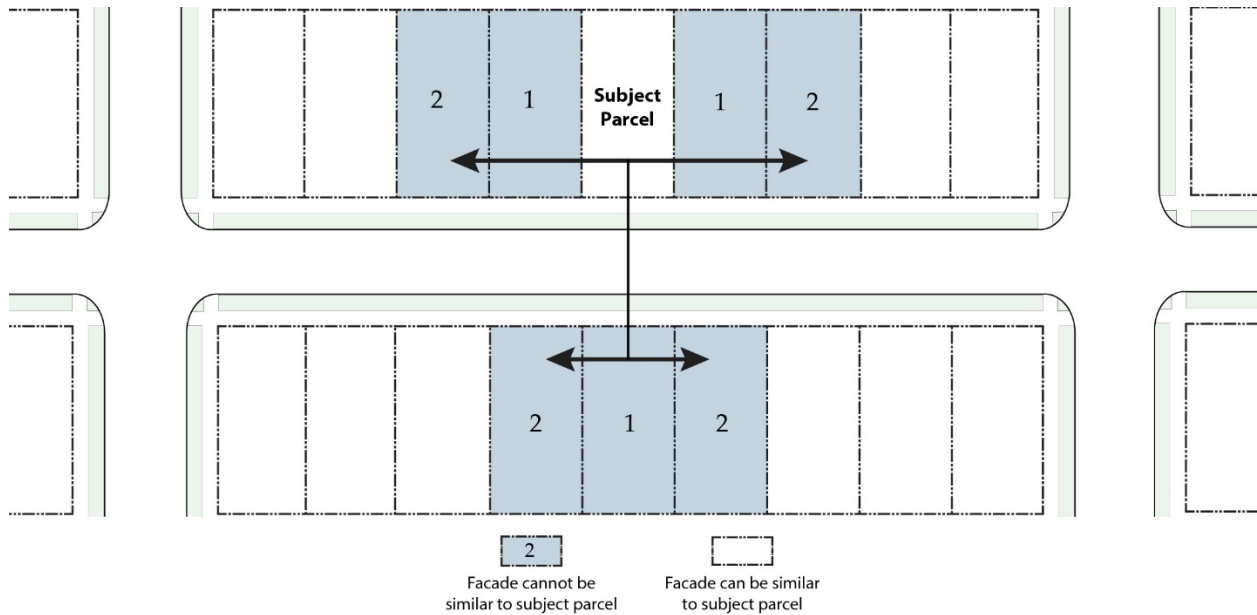

Figure 8.10.2 Anti-Monotony Façade Separation



C. Design Requirements for Multiple-Unit Dwellings and Townhouse Dwelling Units. [Figure 8.10.3 Multiple-Unit Dwelling and Townhouse Dwelling Unit Design Requirements.](#)

1. Façade Articulation. To avoid the appearance of blank walls on multiple-unit and townhouse dwelling units, facades facing the front yard and corner side yard must include façade articulation, such as entrances, bay windows, porches, or other architectural features.
2. Façade Transparency. Minimum transparency is required on facades facing the front yard, corner side yard, and interior side yard. Minimum transparency of 15% is required on facades facing the front yard and corner side yard. Minimum transparency of 10% is required on facades facing the interior side yard.
3. Unified Design. The façades of multiple-unit and townhouse dwelling units must utilize common architectural forms, elements, materials, and colors that wrap around all façades of the building to provide a unified architectural design when the development is viewed from all directions.
4. Building Separation. In developments with more than one building, there must be a minimum separation of 40 feet between two front facades, two rear facades, a front and rear façade, a front and side façade, or a rear and side façade. There must be a minimum separation of 10 feet between two side facades. Walkways, driveways and parking areas may be located within the minimum building separation areas.
5. Doors, Windows, and Balconies. Doors and windows must have frames with raised elements, such as jambs, entablatures, thresholds, and casings, to create articulation. Windows must be set back into or projected out from the façade to provide façade depth and shadow. Bay windows and balconies are encouraged to provide dimensional elements on a façade.
6. Roofs. Sloped roofs must include eaves of at least six inches in width. Roof forms must be articulated so that varied planes and massing within the overall roof are provided. Large monotonous roofs and simple pitched roofs without breaks in the expanse of the roof are prohibited. For flat roofs, the use of cornices and/or parapets is required to break up the roofline.

Figure 8.10.3 Multiple-Unit Dwelling and Townhouse Dwelling Unit Design Requirements

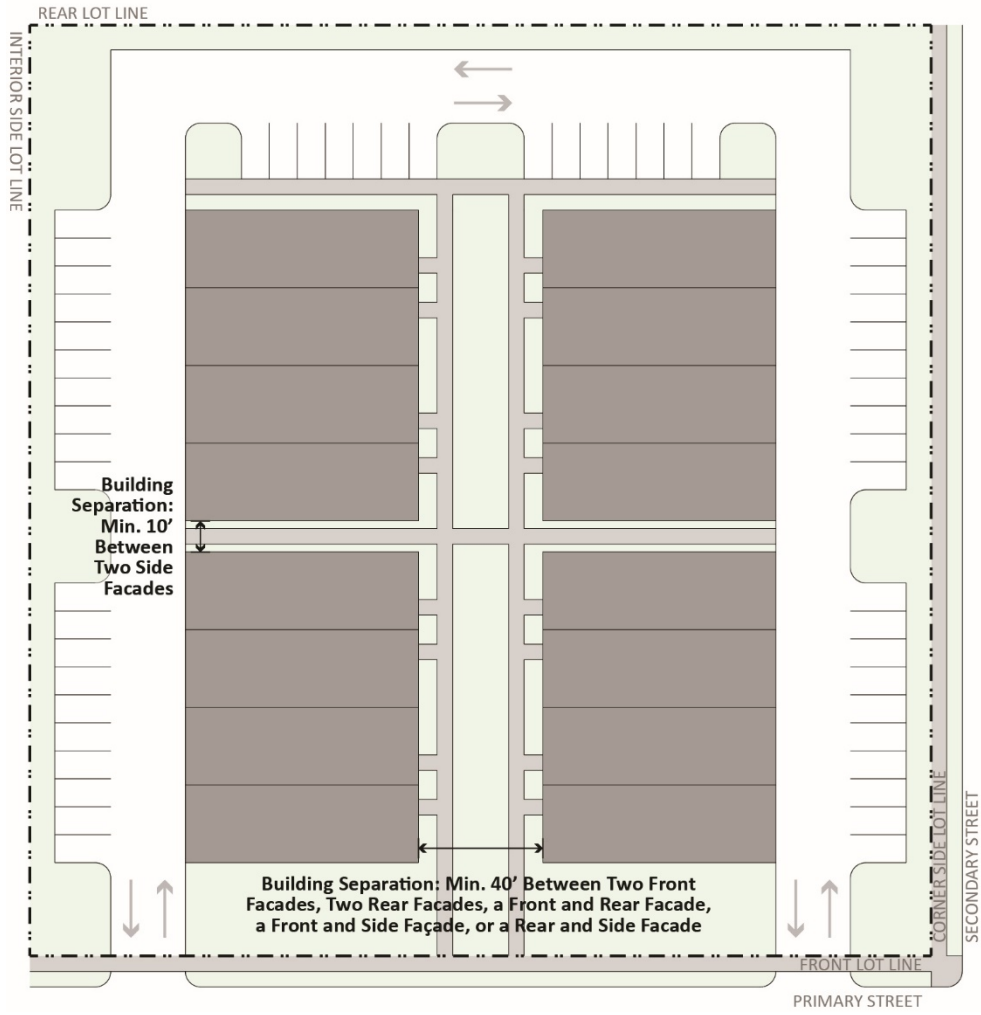
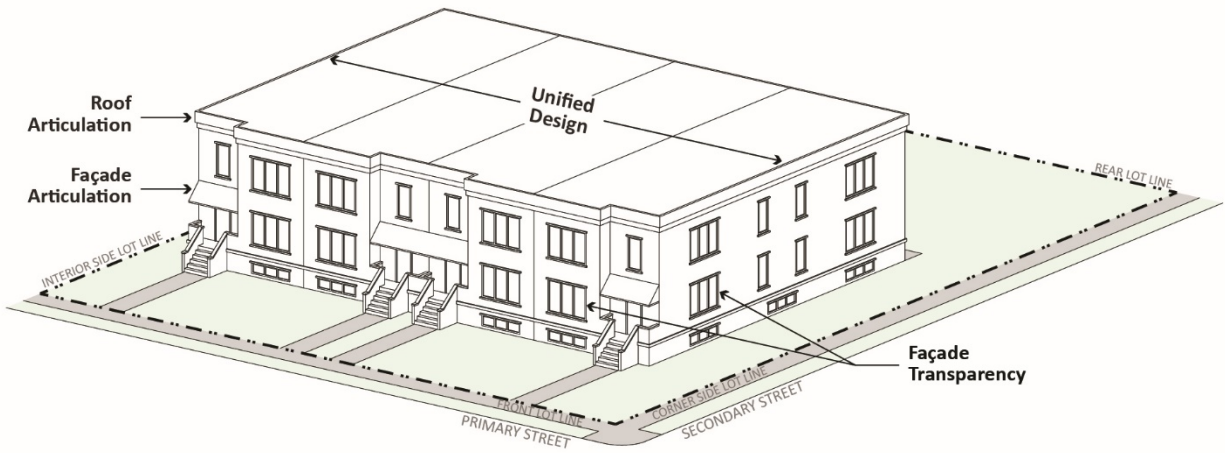

8.11 R-1 Single-Unit Dwelling District

Table 8.11.1 R-1 District Requirements, Figure 8.11.1 R-1 District Requirements: Plan View, and Figure 8.11.2 R-1 District Requirements: 3-D View establish bulk and setback regulations for the R-1 District. See 9.03 (Accessory Structures and Uses) for provisions related to accessory structures.

Table 8.11.1 R-1 District Requirements

Bulk Requirements		
	Minimum Lot Area	9,000 sf
A	Minimum Lot Width	75 ft
B	Maximum Principal Building Height	2.5 stories and 35 ft
	Maximum Primary Impervious Coverage	40%
	Maximum Total Impervious Coverage	50%
Setback Requirements		
C	Minimum Front Setback	30 ft
D	Minimum Corner Side Setback	20 ft
E	Minimum Interior Side Setback	12 ft
F	Minimum Rear Setback	30 ft

Figure 8.11.1 R-1 District Requirements: Plan View

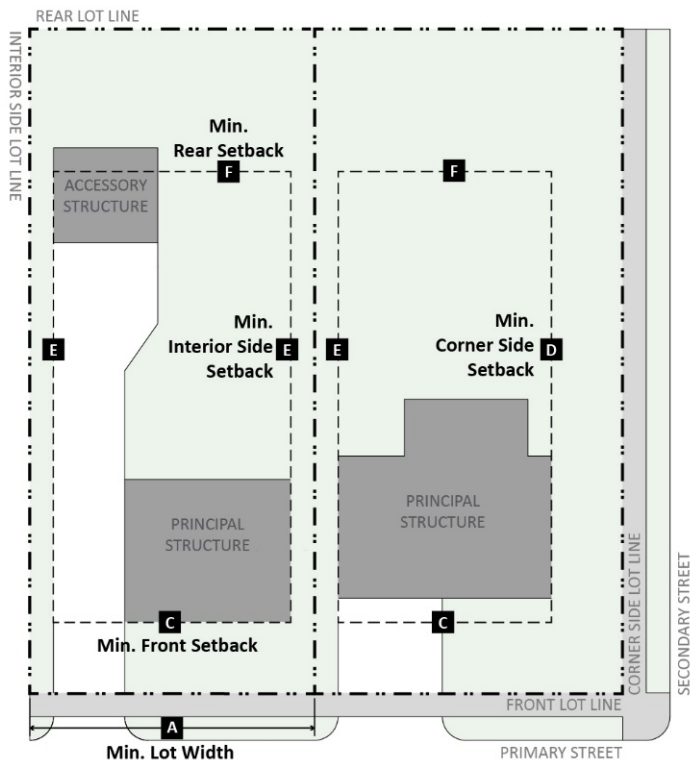
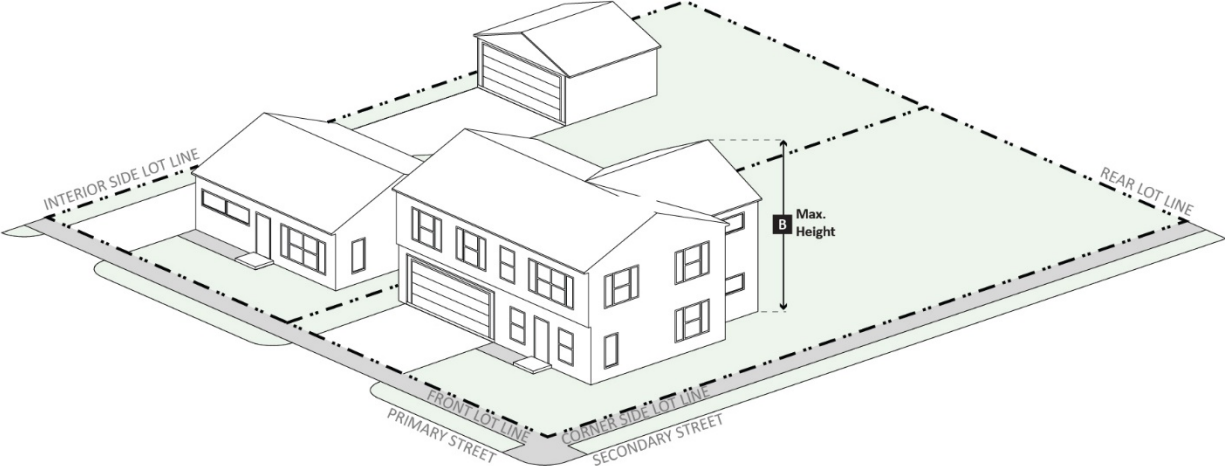

Figure 8.11.2 R-1 District Requirements: 3-D View



8.12 R-2 Single-Unit Dwelling District

Table 8.12.1 R-2 District Requirements, Figure 8.12.1 R-2 District Requirements: Plan View, and Figure 8.12.2 R-2 District Requirements: 3-D View establish bulk and setback regulations for the R-2 District. See Section 9.03 (Accessory Structures and Uses) for provisions related to accessory structures.

Table 8.12.1 R-2 District Requirements

Bulk Requirements		
	Minimum Lot Area	7,200 sf
A	Minimum Lot Width	60 ft
B	Maximum Principal Building Height	2.5 stories and 35 ft
	Maximum Primary Impervious Coverage	45%
	Maximum Total Impervious Coverage	55%
Setback Requirements		
C	Minimum Front Setback	25 ft
D	Minimum Corner Side Setback	15 ft
E	Minimum Interior Side Setback	6 ft
F	Minimum Rear Setback	30 ft

Figure 8.12.1 R-2 District Requirements: Plan View

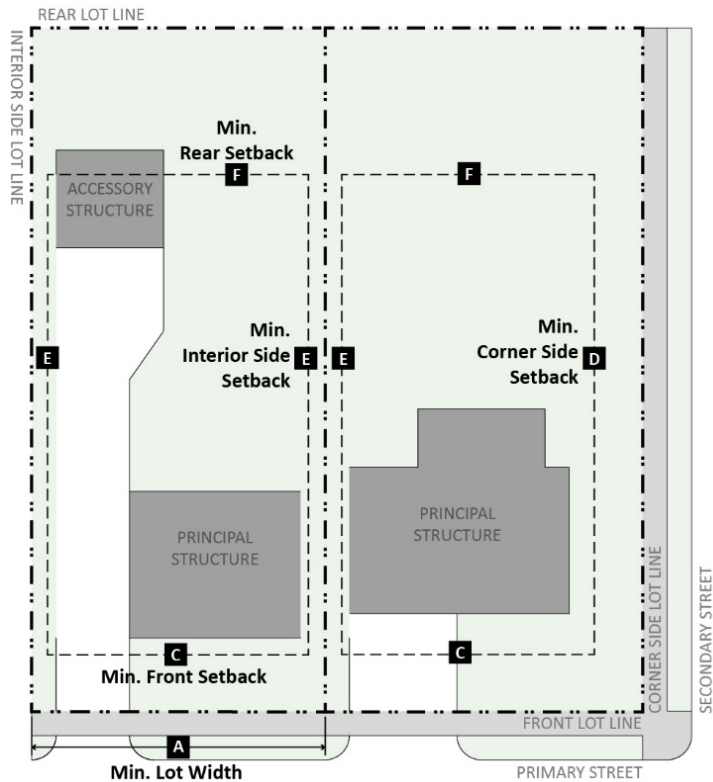
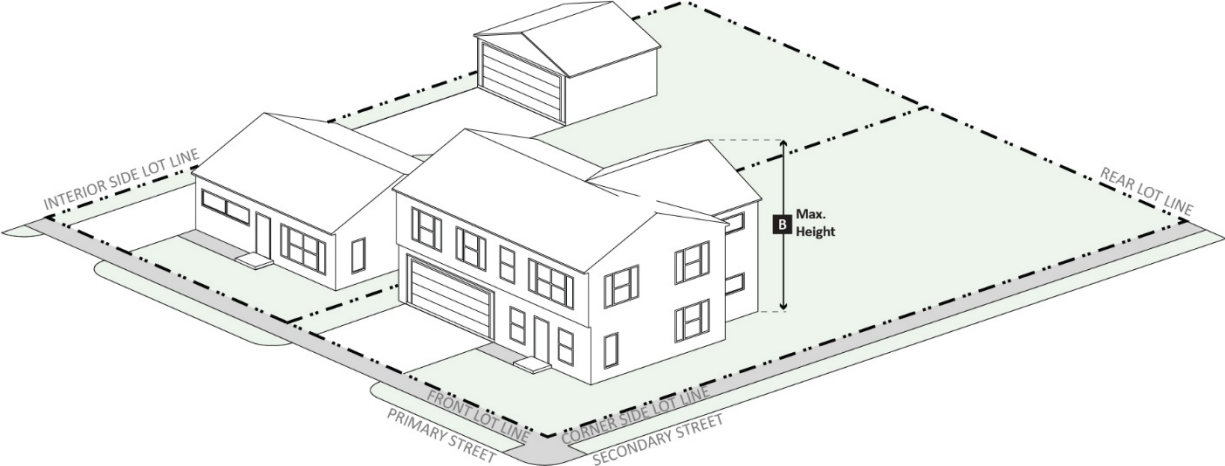

Figure 8.12.2 R-2 District Requirements: 3-D View



8.13 R-3 Single-Unit Dwelling District

Table 8.13.1 R-3 District Requirements, Figure 8.13.1 R-3 District Requirements: Plan View, and Figure 8.13.2 R-2 District Requirements: 3-D View establish bulk and setback regulations for the R-3 District. See Section 9.03 (Accessory Structures and Uses) for provisions related to accessory structures.

Table 8.13.1 R-3 District Requirements

Bulk Requirements		
	Minimum Lot Area	5,500 sf
A	Minimum Lot Width	45 ft
B	Maximum Principal Building Height	2.5 stories and 35 ft
	Maximum Primary Impervious Coverage	55%
	Maximum Total Impervious Coverage	65%
Setback Requirements		
C	Minimum Front Setback	15 ft
D	Minimum Corner Side Setback	10 ft
E	Minimum Interior Side Setback	5 ft
F	Minimum Rear Setback	20 ft

Figure 8.13.1 R-3 District Requirements: Plan View

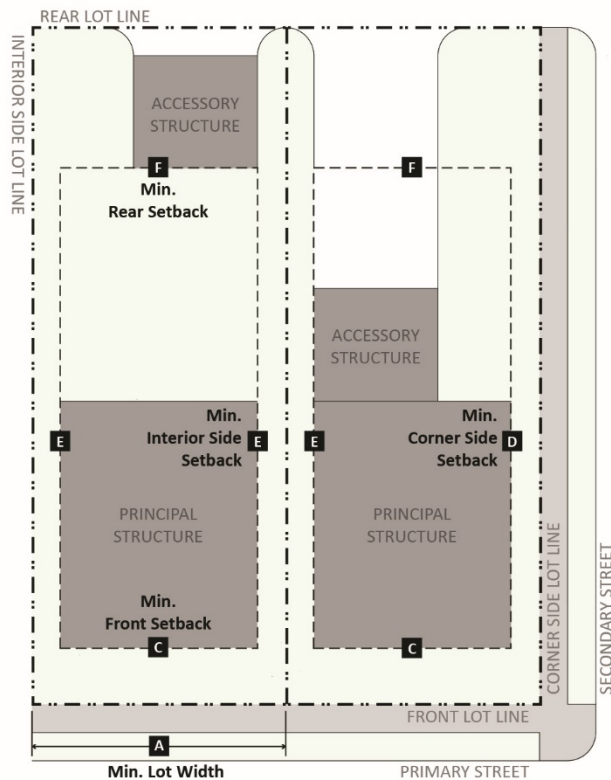
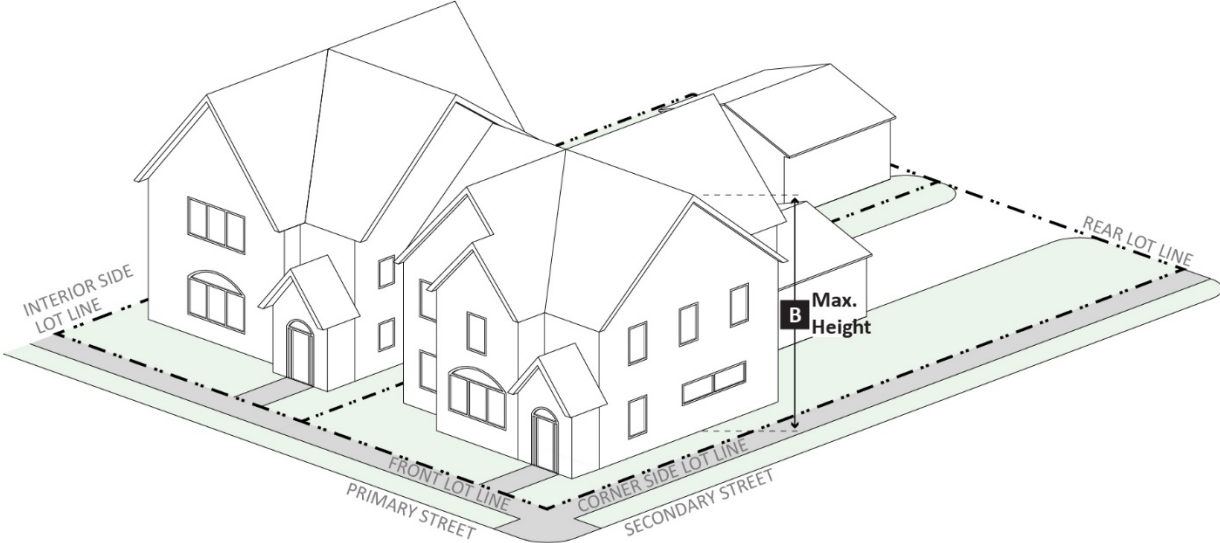

Figure 8.13.2 R-3 District Requirements: 3-D View



8.14 R-4 Attached Single-Unit Dwelling District

Table 8.14.1 R-4 District Requirements, Figure 8.14.1 R-4 District Requirements: Plan View, and Figure 8.14.2 R-4 District Requirements: 3-D View establish bulk and setback regulations for the R-4 District. See Section 9.03 (Accessory Structures and Uses) for provisions related to accessory structures.

Table 8.14.1 R-4 District Requirements

Bulk Requirements		
	Minimum Lot Area	9,000 sf
A	Minimum Lot Width	75 ft
B	Maximum Principal Building Height	2.5 stories and 35 ft
	Maximum Primary Impervious Coverage	60%
	Maximum Total Impervious Coverage	70%
Setback Requirements		
C	Minimum Front Setback	25 ft
D	Minimum Corner Side Setback	10 ft
E	Minimum Interior Side Setback	10 ft
F	Minimum Rear Setback	30 ft

Figure 8.14.1 R-4 District Requirements: Plan View

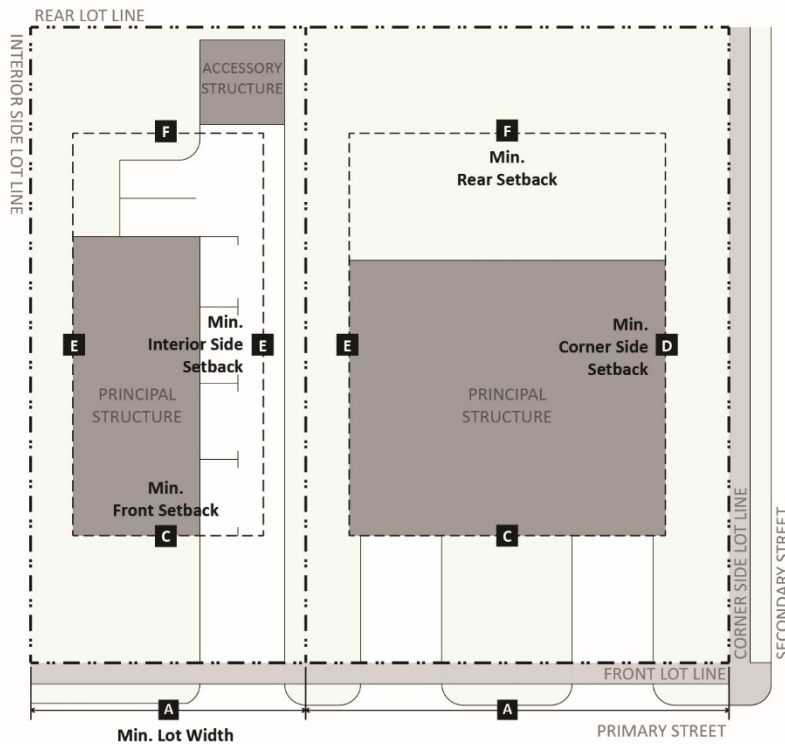
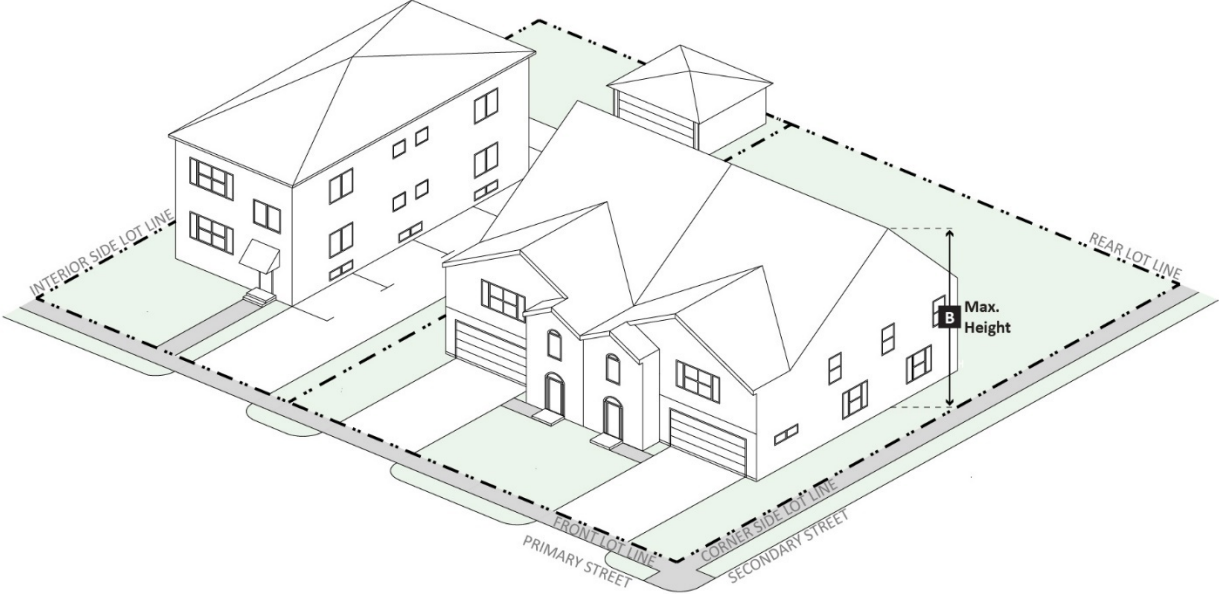

Figure 8.14.2 R-4 District Requirements: 3-D View



8.15 R-5 Multiple-Unit Dwelling District

Table 8.15.1 R-5 District Requirements, Figure 8.15.1 R-5 District Requirements: Plan View, and Figure 8.15.2 R-5 District Requirements: 3-D View establish bulk and setback regulations for the R-5 District. See Section 9.03 (Accessory Structures and Uses) for provisions related to accessory structures.

Table 8.15.1 R-5 District Requirements

Bulk Requirements		
	Minimum Lot Area	20,000 sf
A	Minimum Lot Width	100 ft
B	Maximum Principal Building Height	4 stories and 60 ft
	Maximum Primary Impervious Coverage	65%
	Maximum Total Impervious Coverage	75%
Setback Requirements		
C	Minimum Front Setback	25 ft
D	Minimum Corner Side Setback	25 ft
E	Minimum Interior Side Setback	20 ft
F	Minimum Rear Setback	30 ft

Figure 8.15.1 R-5 District Requirements: Plan View

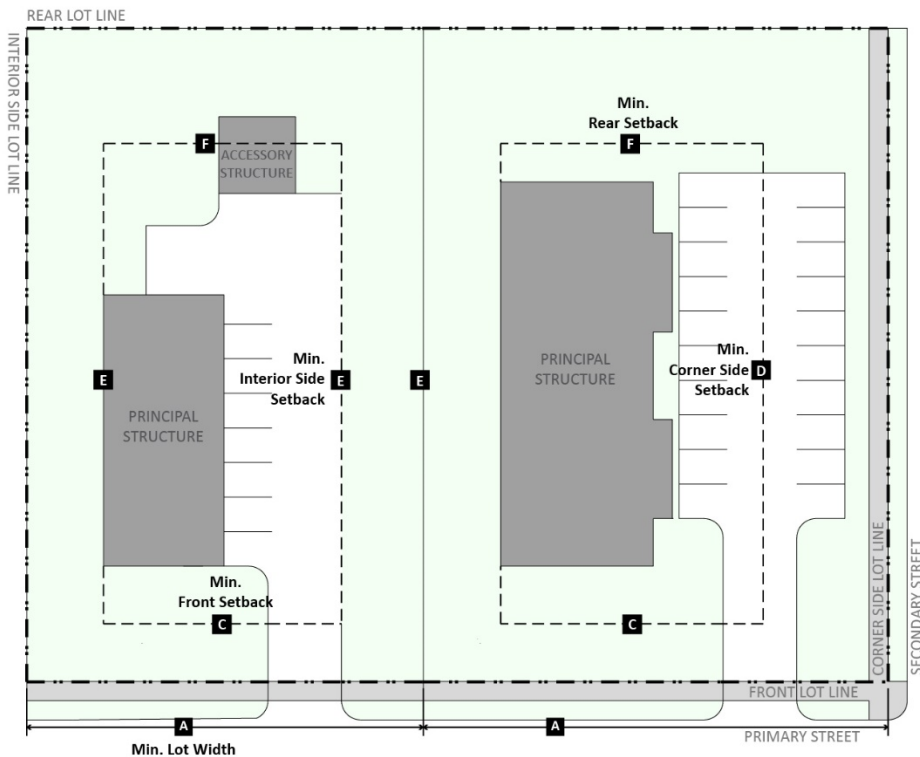

Figure 8.15.-2 R-5 District Requirements: 3-D View



8.16 Design Requirements for Business Zoning Districts

- A. Applicability. The design requirements in this section apply to all new construction and significant exterior renovation of existing structures within the Village’s MD, B-1, and B-2 Districts, with the exception of single-unit dwellings, two-unit dwellings, townhouse dwelling units, and multiple-unit dwellings. For additional design requirements specific to each business zoning district, see [Section 8.17 \(MD Mill District\)](#), [Section 8.18 \(B-1 Neighborhood Business District\)](#), and [Section 8.19 \(B-2 Regional Business District\)](#). For design requirements specific to single-unit dwellings, two-unit dwellings, townhouse dwelling units, and multiple-unit dwellings within the Village’s business zoning districts see [Section 8.10 \(Design Requirements for Residential Zoning Districts\)](#).
- B. Design Requirements.
1. Façade Design.
 - a. Defined Base, Middle, and Top. Buildings with multiple stories must be designed with a distinct base (ground story), middle, and top. The base of the building must be defined from the upper stories by a horizontal expression line, which is a decorative, three-dimensional linear element protruding or indented at least two inches from a building façade. The top of the building must be crowned with a similar expression line no less than six inches in width.
 - b. Façade Articulation. For buildings with more than 50 feet of building width or depth, vertical architectural or structural elements must be incorporated along all street-facing façades at regular intervals to divide large, flat wall planes. Examples of such elements include texture change, material change, color change, or wall articulation change, such as an offset, pilaster, column, reveal, or vertical expression line, of no less than six inches.
 2. Building Façade Materials.
 - a. Allowed Materials. Durable and natural materials are allowed on any building façade, such as stone, brick, stucco, concrete, burnished concrete masonry units, fiber cement siding, and non-reflective glass, unless otherwise limited by [Section 8.16.B.2.b \(Limited Materials\)](#).
 - b. Limited Materials. The following materials may only be utilized for trim or architectural details, and must not exceed 20 percent of the total area of any building façade: utility brick, vinyl or metal siding, metal wall panels, exposed aggregate (rough finish) concrete wall panels, non-burnished concrete masonry units, exterior insulation and finishing systems, fiberglass, plastic, untreated wood, and mirrored glass. The painting of brick, limestone, or other natural stone is prohibited so such materials retain their natural colors.
 3. Building Details. Pedestrian-scale elements are encouraged on any building façade fronting a public right-of-way, such as decorative lighting not more than nine feet in height, planters, and awnings.
 4. Roof Design. Green roof, white roof, and blue roof designs are encouraged.
- C. Explanation of Table Requirements. The following information explains the design requirements established in Tables [8.17.1 MD District Requirements](#), [8.18.1 B-1 District Requirements](#), and [8.19.1 B-2 District Requirements](#). Refer to [Figure 8.16.1 Business District Design Requirements](#)

1. Minimum Street Frontage. The minimum proportion of a principal building required to be located adjacent to a right-of-way expressed as a percentage of the total length of the lot line adjacent to the right-of-way.
2. Parking Location. The yards in which an off-street parking lot is allowed.
3. Minimum Transparency. The amount of highly transparent, non-reflective glass required as a percentage of the total area of the street-facing ground story façades between two and eight feet above grade. Tinting of glass in excess of 20 percent is prohibited. Buildings larger than 30,000 square feet are exempt from these standards.
4. Principal Entrance Location. The façade on which the principal building entrance must be located.

Figure 8.16.1 Business Districts Design Requirements

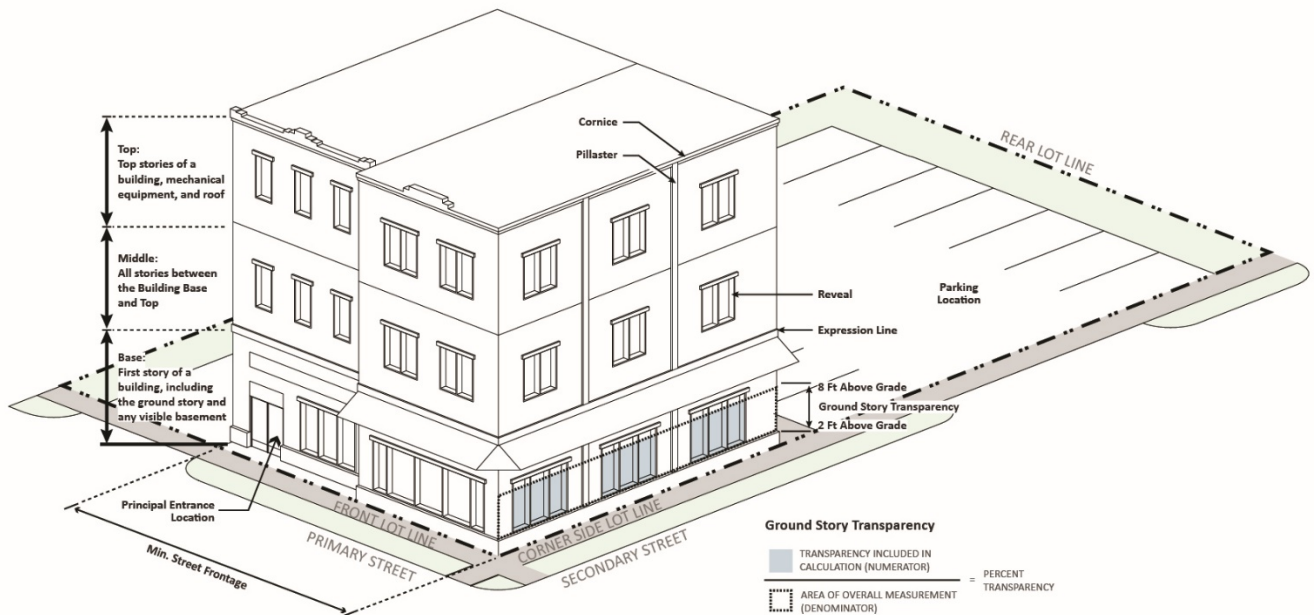

8.17 MD Mill District

Table 8.17.1 MD District Requirements, Figure 8.17.1 MD District Requirements: Plan View, and Figure 8.17.2 MD District Requirements: 3-D View establish bulk and setback regulations for the MD District. See Section 9.03 (Accessory Structures and Uses) for provisions related to accessory structures.

Table 8.17.1 MD District Requirements

Bulk Requirements		
	Minimum Lot Area	N/A
A	Minimum Lot Width	50 ft
B	Maximum Principal Building Height	4 stories and 56 ft
	Maximum Impervious Coverage	80%
	Minimum Additional Semi-Pervious Coverage	20%
Setback Requirements		
C	Maximum Front Setback	10 ft
D	Maximum Corner Side Setback	10 ft
E	Minimum Interior Side Setback	N/A
F	Minimum Rear Setback	N/A
	Minimum Setback Adjacent to a Residential District	10 ft
Design Requirements		
G	Minimum Street Frontage on Primary Street	95%
H	Parking Location	Rear yard
	Minimum Transparency	60%
	Principal Entrance Location	Front or corner side façade

Figure 8.17.1 MD District Requirements: Plan View

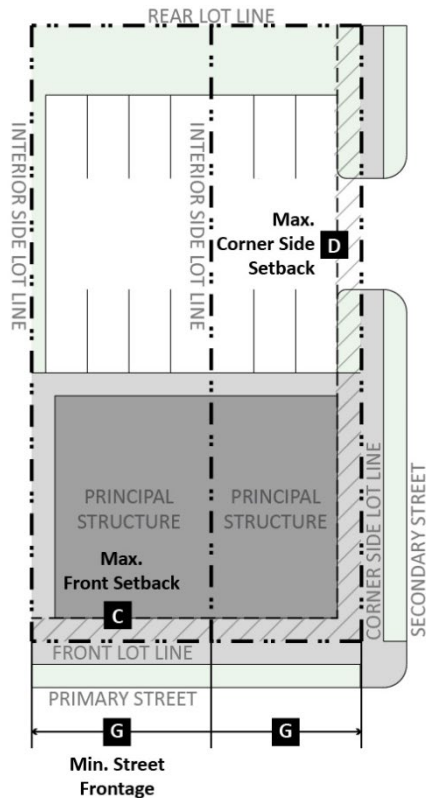
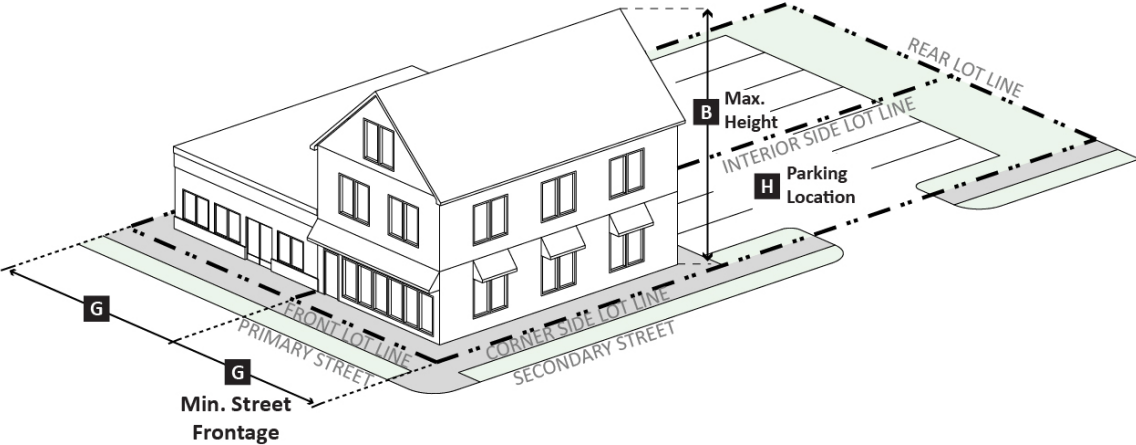

Figure 8.17.2 MD District Requirements: 3-D View



8.18 B-1 Neighborhood Business District

Table 8.18.1 B-1 District Requirements, Figure 8.18.1 B-1 District Requirements: Plan View, and Figure 8.18.2 B-1 District Requirements: 3-D View establish bulk and setback regulations for the B-1 District. See Section 9.03 (Accessory Structures and Uses) for provisions related to accessory structures.

Table 8.18.1 B-1 District Requirements

Bulk Requirements		
	Minimum Lot Area	N/A
A	Minimum Lot Width	45 ft
B	Maximum Principal Building Height	4 stories and 56 ft
	Maximum Total Impervious Coverage	90%
Setback Requirements		
C	Maximum Front Setback	75 ft
D	Maximum Corner Side Setback	75 ft
E	Minimum Interior Side Setback	5 ft
F	Minimum Rear Setback	20 ft
	Minimum Setback Adjacent to a Residential District	20 ft
Design Requirements		
G	Parking Location	Front, corner side, interior side, or rear yard
	Minimum Transparency	60%
	Principal Entrance Location	Front or corner side façade

Figure 8.18.1 B-1 District Requirements: Plan View

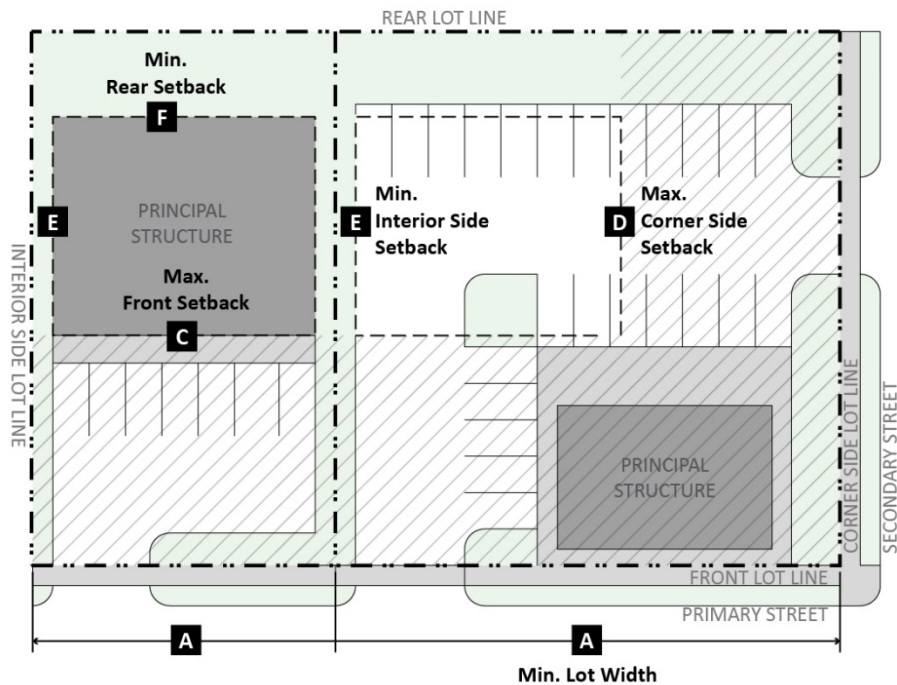
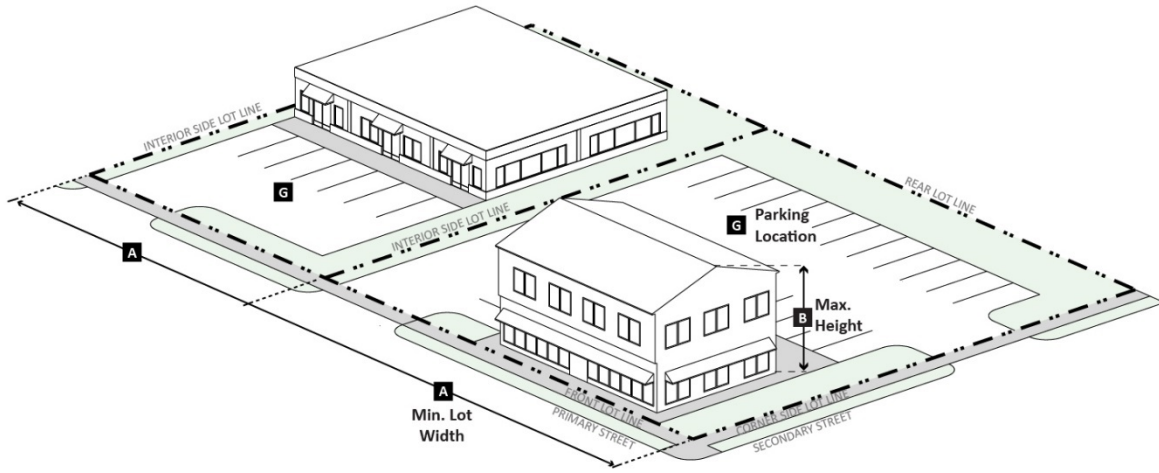

Figure 8.18.2 B-1 District Requirements: 3-D View



8.19 B-2 Regional Business District

Table 8.19.1 B-2 District Requirements, Figure 8.19.1 B-2 District Requirements: Plan View, and Figure 8.19.2 B-2 District Requirements: 3-D View establish bulk and setback regulations for the B-2 District. See Section 9.03 (Accessory Structures and Uses) for provisions related to accessory structures.

Table 8.19.1 B-2 District Requirements

Bulk Requirements		
	Minimum Lot Area	N/A
A	Minimum Lot Width	50 ft
B	Maximum Principal Building Height	4 stories and 56 ft
	Maximum Total Impervious Coverage	75%
Setback Requirements		
C	Maximum Front Setback	N/A
D	Maximum Corner Side Setback	75 ft
E	Minimum Interior Side Setback	10 ft
F	Minimum Rear Setback	20 ft
	Minimum Setback Adjacent to a Residential District	20 ft
Design Requirements		
G	Parking Location	Front, corner side, interior side, or rear yard
	Minimum Transparency	60%
	Principal Entrance Location	Front or corner side façade

Figure 8.19.1 B-2 District Requirements: Plan View

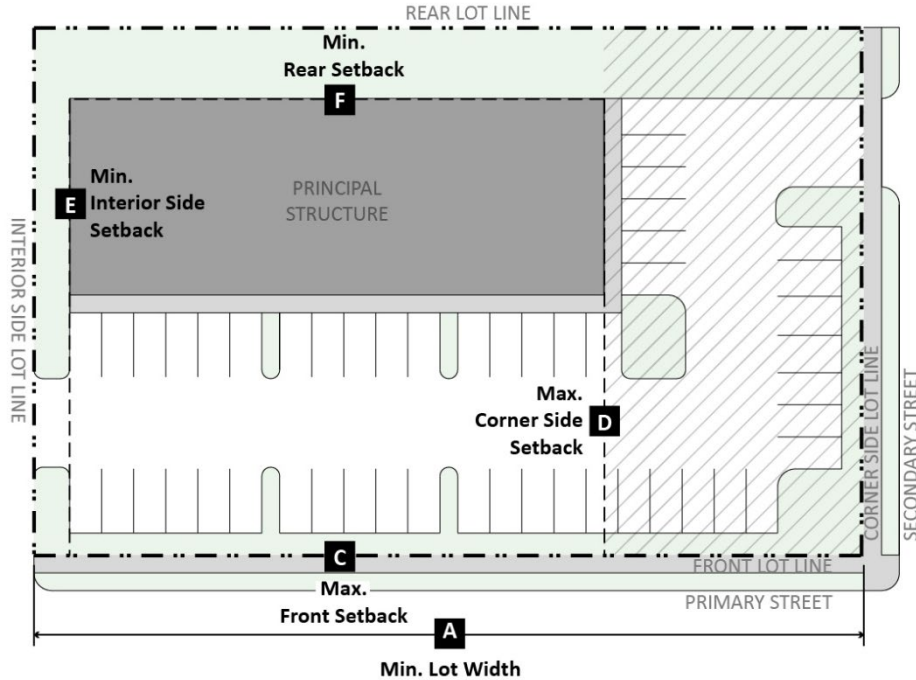
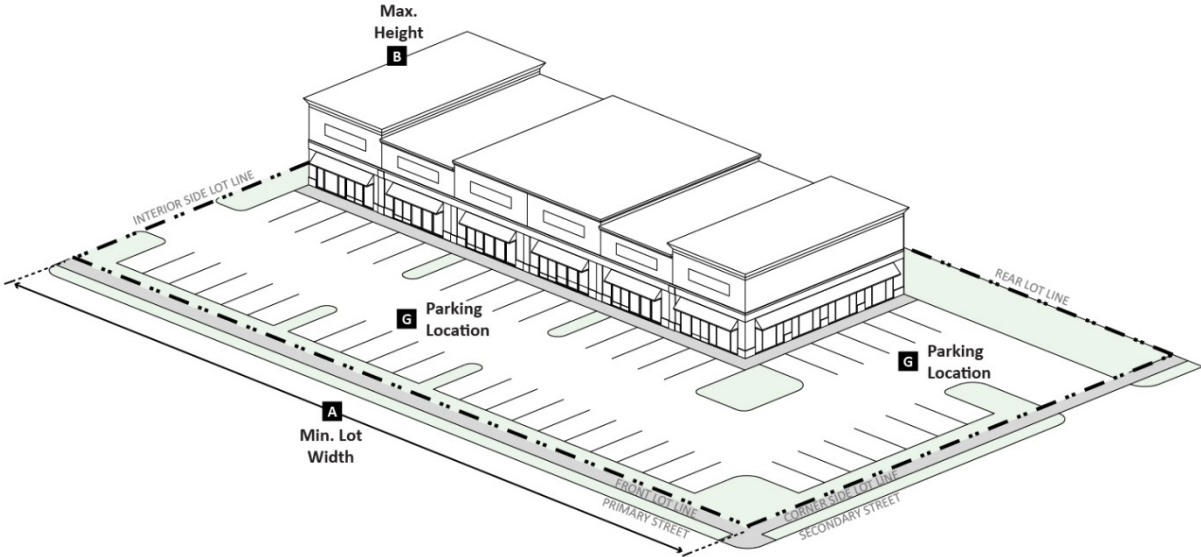

Figure 8.19.2 B-2 District Requirements: 3-D View



8.20 Design Requirements for Manufacturing Zoning Districts

- A. Applicability. The design requirements in this section apply to all new construction and significant exterior renovation of existing structures within the Village's M-1 and M-2 Districts, with the exception of single-unit dwellings, two-unit dwellings, townhouse dwelling units, and multiple-unit dwellings. See [Section 8.21 \(M-1 Light Manufacturing District\)](#) and [Section 8.22 \(M-2 General Manufacturing District\)](#) for additional design requirements specific to each manufacturing zoning district. Refer to [Figure 8.20.1 Manufacturing Design Requirements](#). See [Section 8.10 \(Design Requirements for Residential Zoning Districts\)](#) for design requirements specific to single-unit dwellings, two-unit dwellings, townhouse dwelling units, and multiple-unit dwellings within the Village's manufacturing zoning districts.
- B. Design Requirements.
1. Façade Articulation. For buildings with more than 100 ft of building width or depth, vertical architectural or structural elements must be incorporated along all street-facing façades at regular intervals to vertically divide large, flat wall planes. Examples of such elements include texture change, material change, color change, or wall articulation change, such as an offset, pilaster, column, reveal, or vertical expression line, of no less than six inches.
 2. Building Façade Materials.
 - a. Allowed Materials. Durable and natural materials are allowed on any building façade, such as stone, brick, stucco, concrete, burnished concrete masonry units, fiber cement siding, and non-reflective glass, unless otherwise limited by [Section 8.20.B.2.b \(Limited Materials\)](#).
 - b. Limited Materials. The following materials may only be utilized for trim or architectural details, and must not exceed 25 percent of the total area of any building façade: utility brick, vinyl or metal siding, metal wall panels, exposed aggregate (rough finish) concrete wall panels, non-burnished concrete masonry units, exterior insulation and finishing systems, fiberglass, plastic, untreated wood, and mirrored glass. The painting of brick, limestone, or other natural stone is prohibited so such materials retain their natural colors.
 3. Roof Design. Green roof, white roof, and blue roof designs are encouraged.
 4. Parking Location. Parking areas may be located in the front, corner side, interior side, or rear yards. Parking areas located in the front or corner side yard must not be the dominant visual element of the site when viewed from a right-of-way. Parking areas of 50 parking spaces or more must be located in interior side and rear yards.
 5. Principal Entrance Location. Principal entrances must be located on the front or corner side façade.

Figure 8.20.1 Manufacturing Design Requirements

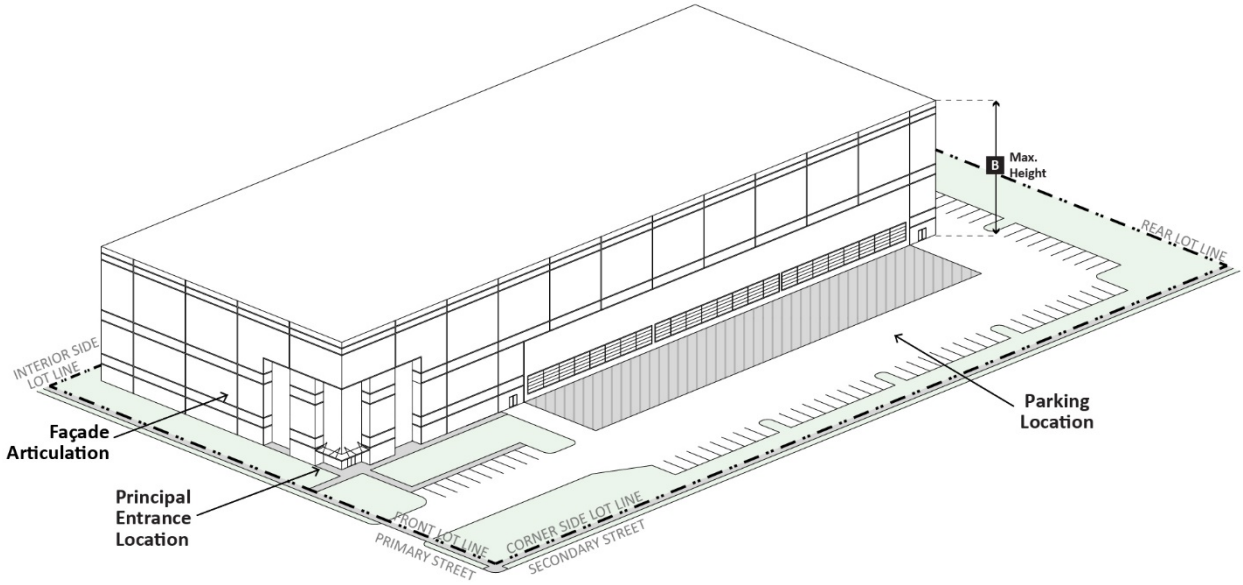

8.21 M-1 Light Manufacturing District

Table 8.21.1 M-1 District Requirements, Figure 8.21.1 M-1 District Requirements: Plan View, and Figure 8.21.2 M-1 District Requirements: 3-D View establish bulk and setback regulations for the M-1 District. See Section 9.03 (Accessory Structures and Uses) for provisions related to accessory structures.

Table 8.21.1 M-1 District Requirements

Bulk Requirements		
	Minimum Lot Area	N/A
A	Minimum Lot Width	100 ft
B	Maximum Principal Building Height	65 ft
	Maximum Impervious Coverage	80%
Setback Requirements		
C	Minimum Front Setback	25 ft
D	Minimum Corner Side Setback	25 ft
E	Minimum Interior Side Setback	10 ft
F	Minimum Rear Setback	20 ft
	Minimum Setback Adjacent to a Residential District	30 ft

Figure 8.21.1 M-1 District Requirements: Plan View

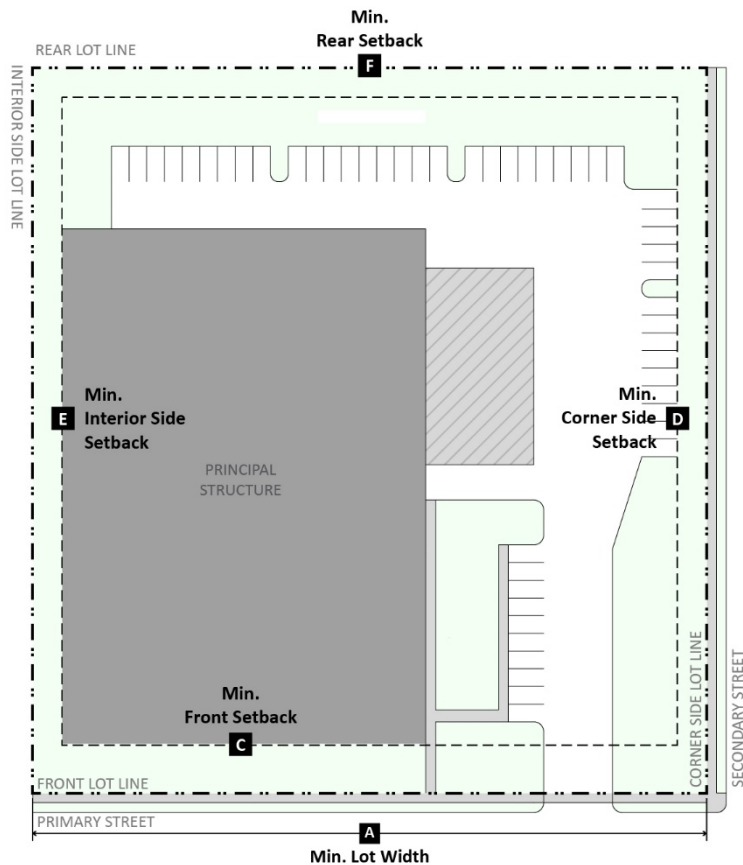
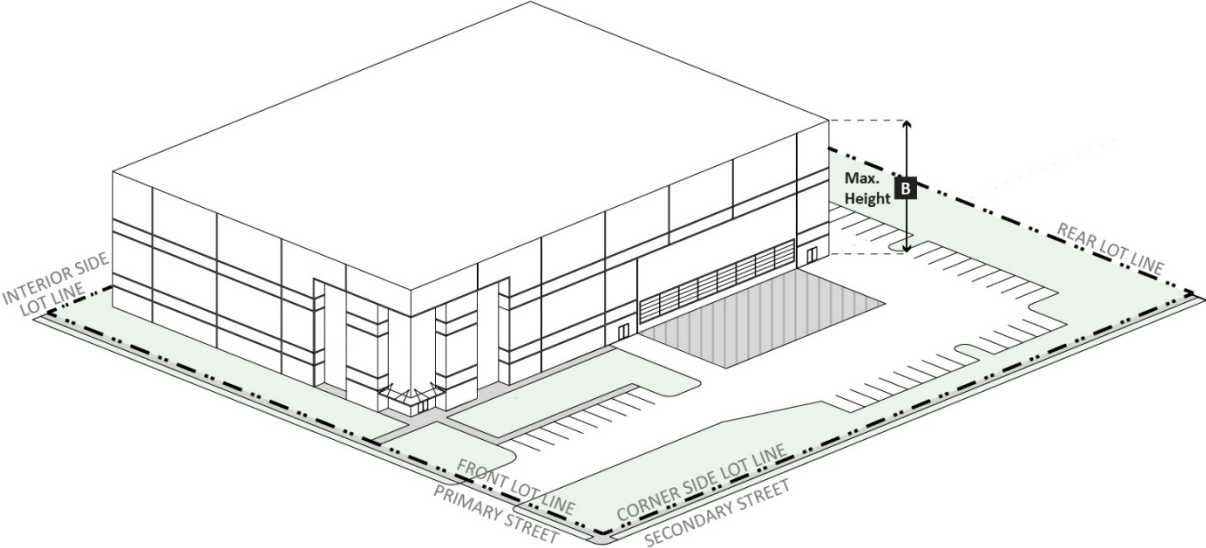

Figure 8.21.2 M-1 District Requirements: 3-D View



8.22 M-2 General Manufacturing District

Table 8.22.1 M-2 District Requirements, Figure 8.22.1 M-2 District Requirements: Plan View, and Figure 8.22.2 M-2 District Requirements: 3-D View establish bulk and setback regulations for the M-2 District. See Section 9.03 (Accessory Structures and Uses) for provisions related to accessory structures.

Table 8.22.1 M-2 District Requirements

Bulk Requirements		
	Minimum Lot Area	N/A
A	Minimum Lot Width	100 ft
B	Maximum Principal Building Height	100 ft
	Maximum Impervious Coverage	80%
Setback Requirements		
C	Minimum Front Setback	25 ft
D	Minimum Corner Side Setback	25 ft
E	Minimum Interior Side Setback	10 ft
F	Minimum Rear Setback	20 ft
	Minimum Setback Adjacent to a Residential District	30 ft

Figure 8.22.1 M-2 District Requirements: Plan View

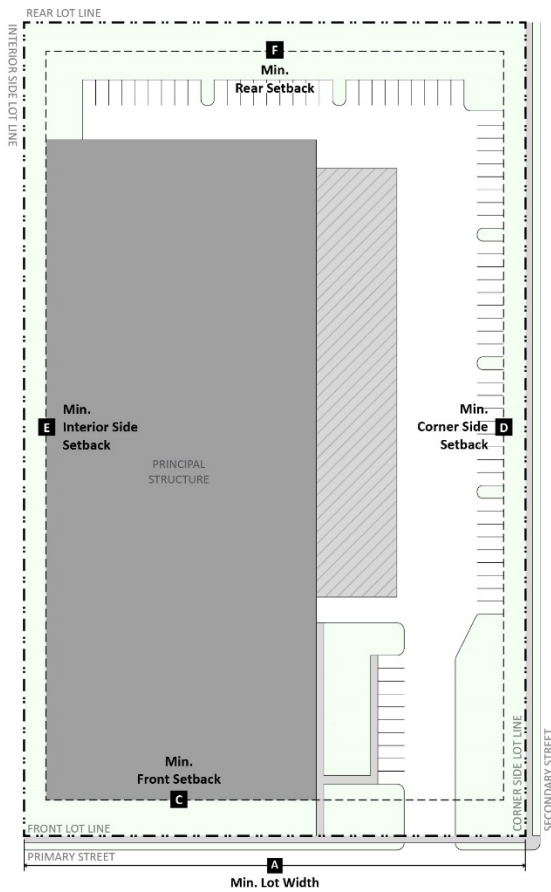
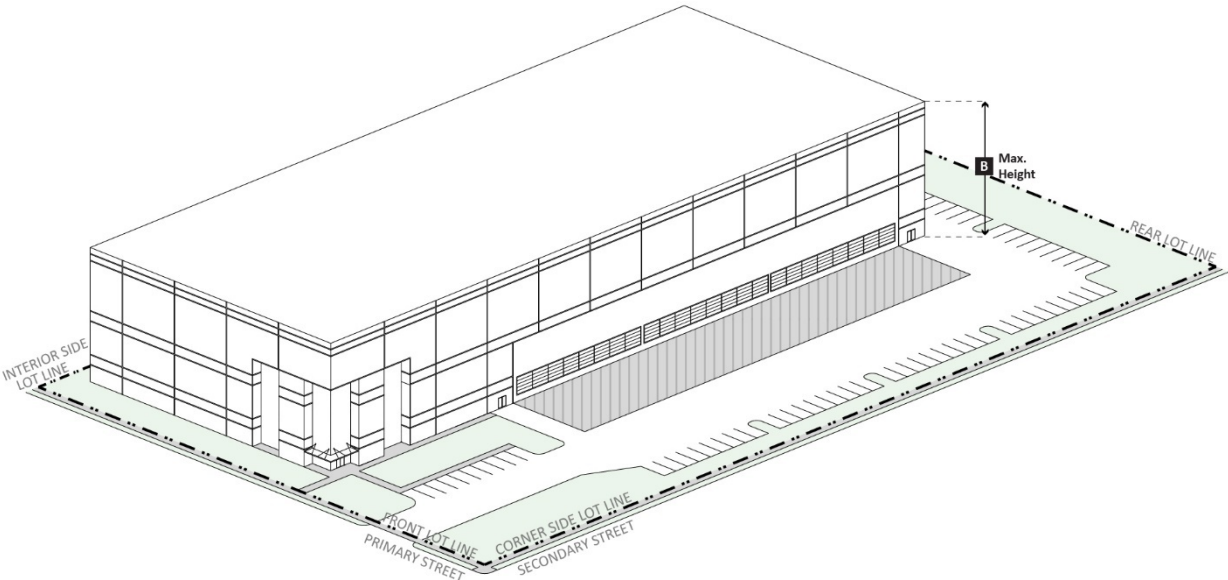

Figure 8.22.2 M-2 District Requirements: 3-D View



SECTION 9: USES

[9.01 General Provisions](#)

[9.02 Principal Uses and Structures](#)

[9.03 Accessory Uses and Structures](#)

[9.04 Temporary Uses and Structures](#)

[9.05 Environmental Performance Standards](#)

9.01 General Provisions

- A. Purpose. The purpose of this Section is to protect and promote the health, safety, comfort, convenience, and general welfare of the public by providing clear standards for the use of the land within the Village.
- B. General Standards. The following standards apply generally to the uses allowed by this Ordinance.
1. Federal, State, and Local Requirements. All uses must comply with relevant federal, state, and local standards including licensing, registration, health, and safety requirements.
 2. Number of Principal Uses. A lot may contain more than one principal use.
 3. Principal, Accessory, and Temporary Uses. Each use may function as a principal, accessory, or temporary use on a lot, unless otherwise specified.
 4. Uses within Enclosed Buildings or Structures. Each use must be primarily located within an enclosed building or structure. Uses that typically include an outdoor component are exempt from this requirement, such as community garden, outdoor entertainment, outdoor recreation, outdoor storage area, and park. All buildings and structures must comply with the applicable requirements of this Section and [Section 8 \(Zoning District Regulations\)](#).
 5. Exempt Public Uses. The following public uses are allowed to be erected, constructed, altered, or maintained in any zoning district with Village approval.
 - a. Traffic signals, fire hydrants, and other similar public safety devices.
 - b. Utility poles, wires, mains, drains, pipes, conduits, cables, wireless telecommunication small cells, and other similar public service devices.
- C. Interpretation. Some of the uses and structures included in this Section are defined as broad categories that contain a group of similar uses. See [Section 13 \(Definitions\)](#) for definitions of the uses and structures included in this Section.
1. Unlisted Similar Use or Structure. If a use or structure is not listed in this Section, but is similar in nature and impact to a use or structure allowed within a zoning district, the Zoning Officer may interpret the unlisted use or structure as an allowed use.
 - a. The unlisted use or structure is subject to any use standards that apply to the similar allowed use or structure.
 - b. The Zoning Officer may interpret an unlisted use as requiring the approval of a special use permit if the similar allowed use requires the approval of a special use permit.

- Unlisted Dissimilar Use or Structure. If a use or structure is not listed in this Section and the Zoning Officer does not deem the use or structure to be similar in nature and impact to a use or structure allowed within a zoning district then the use is not allowed and may only be approved through an amendment of this Ordinance (refer to [Section 4.06 \(Text or Map Amendment\)](#)).

9.02 Principal Uses and Structures

A. Use Table. [Table 9.02.1 Principal Uses and Structures](#) establishes the uses allowed in each zoning district. Each use is given one of the following designations for each zoning district.

- Permitted Use (“P”). A “P” indicates that a use is allowed by-right within the designated zoning district provided that it meets all applicable use standards set forth in [Section 9.02.B \(Use Standards for Principal Uses and Structures\)](#).
- Special Use (“S”). An “S” indicates that the use requires the approval of a special use permit (refer to [Section 4.03 \(Special Use Permit\)](#)) in order to be allowed within the designated zoning district, and must meet all applicable use standards set forth in [Section 9.02.B \(Use Standards for Principal Uses and Structures\)](#).
- No Designation. The absence of a letter (a blank space) or the absence of the use from the table indicates that the use is not allowed within the designated zoning district.

Table 9.02.1 Principal Uses and Structures

Principal Uses and Structures	A	R-1	R-2	R-3	R-4	R-5	MD	B-1	B-2	M-1	M-2	Use Standards
Residential												
Community Residence (Large)		P	P	P	P	P						See 9.02.B.7
Community Residence (Small)					P	P						See 9.02.B.7
Dwelling Above the Ground Floor							P	P				None
Live/Work Dwelling							P	S				See 9.02.B.16
Mobile Home Dwelling					S	S						None
Multiple-Unit Dwelling		S	S	S	P	P	S					None
Residential Care Facility						S	S	S	S			None
Single-Unit Dwelling	P	P	P	P	P	P	S					None
Townhouse Dwelling		S	S	P	P	P	P					None
Two-Unit Dwelling		S	S	P	P	P	S					None
Civic and Institutional	A	R-1	R-2	R-3	R-4	R-5	MD	B-1	B-2	M-1	M-2	Use Standards
Cemetery		S	S	S	S	S						None
College or University		S	S	S	S	S	S	S	S			None
Community Garden		P	P	P	P	P		S	S			See 9.02.B.7
Cultural Facility		P	P	P	P	P	P	P	P			None
Elementary, Middle, or High School		P	P	P	P	P	S	S	S			See 9.02.B.12
Government Facility	P	P	P	P	P	P	P	P	P	P	P	See 9.02.B.14
Hospital									S			None
Park	P	P	P	P	P	P	P	P	P	P	P	None
Place of Worship		S	S	S	S	S	S	S	S	S	S	None
Vocational School		S	S	S	S	S	S	S	S	S	S	See 9.02.B.12
Commercial	A	R-1	R-2	R-3	R-4	R-5	MD	B-1	B-2	M-1	M-2	Use Standards
Adult Use											S	See 9.02.B.1
Animal Boarding, Hospital, or Shelter									S	S		See 9.02.B.2
Banquet Hall							S	S	P			None

Principal Uses and Structures	A	R-1	R-2	R-3	R-4	R-5	MD	B-1	B-2	M-1	M-2	Use Standards
Bar/Tavern							S	S	S			None
Bee Colony	P	S										See 9.02.B.3
Body Art Establishment									S	P		None
Cannabis Craft Grower								S	S	S	S	See 9.02.B.4
Cannabis Dispensary								S	S	S	S	See 9.02.B.4
Car Wash								S	P			See 9.02.B.5
Currency Exchange									S			See 9.02.B.8
Day Care Center							S	P	P			See 9.02.B.9
Day Care Home		S	S	S	S	S						See 9.02.B.10
Drive-Through Facility							S	S	P			See 9.02.B.14
Financial Institution							P	P	P			None
Funeral Home/Crematory		S	S						P	S		None
Garden Center								P	P	S		None
Gas Station								S	S			See 9.02.B.13
Golf Course		S	S									None
Hotel/Motel							S	S	S			None
Indoor Entertainment							S	S	S	S		See 9.02.B.15
Indoor Recreation							S	S	P	S	S	See 9.02.B.15
Laundromat								P	P			None
Microbrewery or Microdistillery							S	S	S	S	S	None
Motor Vehicle Operations Facility										P	P	See 9.02.B.17
Motor Vehicle Rental or Motor Vehicle Sales									S	S		See 9.02.B.18
Motor Vehicle Repair and/or Service									S			See 9.02.B.17
Motor Vehicle Repair and/or Service Body Shop									S	S		See 9.02.B.17
Outdoor Dining							S	S	S			See 9.02.B.19
Outdoor Entertainment or Recreation							S	S	S			See 9.02.B.20
Outdoor Storage Area									S	S	S	See 9.02.B.21
Pawn Shop									S			See 9.02.B.8
Payday/Title Loan Establishment									S			See 9.02.B.8
Personal Services Establishment							P	P	P	S		None
Professional Office							P	P	P	P	P	None
Research/Development Facility										P	P	None
Restaurant							P	P	P			None
Retail Goods Establishment							P	P	P	P		None
Self-Service Storage									S	S	S	None
Manufacturing	A	R-1	R-2	R-3	R-4	R-5	MD	B-1	B-2	M-1	M-2	Use Standards
Cannabis Cultivation Center										S	S	See 9.02.B.4
Cannabis Infuser										S	S	See 9.02.B.4
Cannabis Transporter										S	S	See 9.02.B.4
Heavy Manufacturing											S	None
Light Manufacturing									S	P	P	None
Machinery and Equipment Sales and Rental									S	P	P	None
Warehousing, Storage, or Distribution Facility										P	P	None
Other Uses	A	R-1	R-2	R-3	R-4	R-5	MD	B-1	B-2	M-1	M-2	Use Standards
Agricultural Use	P											None
Club, Lodge, or Hall							S	S	S			None
Parking Lot (Primary Use)							S					See 9.02.B.22

Principal Uses and Structures	A	R-1	R-2	R-3	R-4	R-5	MD	B-1	B-2	M-1	M-2	Use Standards
Planned Unit Development	S	S	S	S	S	S	S	S	S	S	S	See 9.02.B.23
Train Station							P					None
Utility	S	S	S	S	S	S	S	S	S	S	S	See 9.02.B.24
Utility-Scale Solar Energy System	S									S	S	See 9.02.B.25
Utility-Scale Wind Energy System	S									S	S	See 9.02.B.26
Wireless Telecommunication Facility	S	S	S	S	S	S	S	S	S	S	S	See 9.02.B.27
Wireless Telecommunication Tower	S	S	S	S	S	S	S	S	S	S	S	See 9.02.B.27

B. Use Standards for Principal Uses and Structures. The following standards apply to principal uses and structures as designated in the Use Standards column of [Table 9.02.1 Principal Uses and Structures](#).

1. Adult Use.

- a. Location. An adult use must not be located within 1,100 feet of any residential zoning district, day care center, elementary school, middle school, high school, park, place of worship, another adult use, or any use where large numbers of minors regularly travel or congregate. An adult use must not be located within 300 feet of the centerline of Illinois Route 30, Illinois Route 31, or Orchard Road.
- b. Off-Site Observation. An adult use must be conducted in a manner that does not permit the observation of material relating to specified sexual activities or specified anatomical areas from any right-of-way or adjacent property.

2. Animal Boarding, Hospital, or Shelter.

- a. Location. Animal boarding facilities, hospitals, and shelters that are not entirely enclosed are not allowed directly adjacent to any residential use.
- b. Outdoor Boarding. Two outdoor dog runs per establishment are allowed. All outdoor animal boarding facilities must be located in the interior side and/or rear yard and must be enclosed with a fence that is a minimum height of six feet. See [Section 9.03.C.14 \(Fence or Wall\)](#) for additional fence standards.
- c. Drainage. Drainage from outdoor dog runs or kennels must not drain onto adjacent properties, into the right-of-way, or into stormwater catchments.
- d. Safety. All animal boarding facilities, hospitals, and shelters must be designed to ensure the safety, health, and well-being of the animals on site, including protection from predators, the elements, and inclement weather.

3. Bee Colony.

- a. Permit and Registration. Prior to erecting a bee colony, an applicant must provide written notice to all adjacent property owners and obtain a permit from the Zoning Officer. Such permits must be renewed annually. Bee colonies must be registered with the Illinois Department of Agriculture and inspected as required. Proof of completed inspection must be submitted to the Zoning Officer within 30 days of inspection.
- b. Location. Bee colonies are allowed in the rear yard of all parcels in the A District, and on parcels larger than 20,000 square feet in the R-1, District. Community bee colonies are allowed with approval of the Zoning Officer on government-owned lots larger than 20,000 square feet in the A, R-1, R-2, R-3, R-4, and R-5 Districts.
- c. Setback. Bee colonies must be located a minimum of 30 feet from any lot line.
- d. Number of Colonies. Two bee colonies are permitted for the first 20,000 square feet of lot area. Two additional colonies may be added for each additional 10,000 square feet thereafter.

- e. Training. Prior to the establishment of a colony, beekeepers must provide the Zoning Officer with documentation that demonstrates completion of a beekeeping course.
 - f. Safety. Beekeepers must requeen colonies that exhibit unusually aggressive behavior, such as stinging or swarming. Beekeepers must ensure that a source of water is accessible on the zoning lot within 50 feet of the colony.
 - g. Insurance. Beekeeping insurance is required, and a copy of the insurance policy must be provided to the Zoning Officer prior to the establishment of a colony.
 - h. Maintenance. Bee colonies must be maintained so as not to become a nuisance. Colonies must be housed in hive structures with removable combs and adequate spacing to avoid overcrowding and swarming.
 - i. Screening. Bee colonies within 40 feet of a lot line must be screened to provide a flyway barrier. Screening must be at least six feet tall, and consist of a solid fence, vegetative barrier, or combination thereof. Screening must extend 10 feet beyond the colony in all directions. The entrance to the hive area must include a latched gate that remains closed when a beekeeper is not present.
 - j. Signs. Warning signs stating bees on premises must be posted on the property in accordance with [Section 12.05.A.10 \(Warning Signs\)](#).
 - k. Species. All bees kept within the Village must be of the species *Apis mellifera* (Western honey bee).
 - l. Sales. The sale of honey or beeswax products produced on-site is allowed. The sale of honey or beeswax products produced off-site is prohibited.
4. Cannabis Craft Grower, Cannabis Dispensary, Cannabis Cultivation Center, Cannabis Infuser, or Cannabis Transporter.
- a. Minimum Spacing. A cannabis craft grower, cannabis dispensary, cannabis cultivation center, cannabis infuser, or cannabis transporter must not be located within 500 feet of a lot zoned or used for residential purposes, or any residential care facility, day care center, day care home, school, college, university, or park. If a lot zoned or used for residential purposes is separated from a cannabis business by a major state roadway, the minimum spacing may be reduced to 250 feet.
 - b. On-Site Consumption. Cannabis products must not be consumed on site.
 - c. Security. The site design of the establishment must incorporate adequate security measures, such as exterior lighting, surveillance cameras, and/or fencing.
5. Car Wash
- a. Stacking Spaces. Stacking spaces associated with a car wash must comply with the requirements of [Section 10.07 \(Vehicle Stacking Requirements\)](#).
 - b. Screening. The street frontage adjacent to any outdoor car wash area must be screened in accordance with the requirements of [Section 11.05.B \(Parking Lot Perimeter Landscape\)](#).
 - c. Overhead Doors. All wash bays must be secured with overhead doors when the establishment is closed.
 - d. Drainage. Drainage from a car wash must not drain onto adjacent properties, into the right-of-way, or into stormwater catchments.
 - e. Traffic Study. The Village may require a traffic study to ensure that a proposed development does not adversely affect safe and efficient traffic circulation for motorists, bicyclists, or pedestrians.

6. Community Garden.
 - a. Site Design. A community garden must be designed and maintained to minimize the amount of water and/or fertilizer that drains or runs off onto adjacent property.
 - b. Sales. No retail sales are permitted on-site in any residential districts.

7. Community Residence (Large) or Community Residence (Small).
 - a. Occupancy. A community residence (large) provides living accommodations for nine or more residents while a community residence (small) provides living accommodations for eight or fewer residents.
 - b. Minimum Spacing. A community residence must not be located within 1,000 feet of another community residence, and more than one community residence must not be located on a block.
 - c. Residential Character. The location and operation of the facility must not alter the residential character of the neighborhood, and the facility must incorporate a residential design that is compatible with the surrounding neighborhood.

8. Currency Exchange, Pawn Shop, Payday or Title Loan Establishment.
 - a. Minimum Spacing.
 - (1) A currency exchange, pawn shop, or payday or title loan establishment must not be located within 1,000 feet of another currency exchange, pawn shop, or payday or title loan establishment.
 - (2) A currency exchange, pawn shop, or payday or title loan establishment must not be located within 500 feet of any residential district, school, day care center, park, or place of worship.
 - b. Location of Transactions. All transactions must occur entirely inside the facility at a service counter. No transactions may be permitted through an exterior walk-up window or drive-through facility.

9. Day Care Center.
 - a. Minimize Adverse Impacts. The design of the facility must minimize traffic congestion, pedestrian hazards, noise, and other adverse impacts on surrounding properties.
 - b. Traffic Study. The Village may require a traffic study to ensure that the proposed development does not adversely affect safe and efficient traffic circulation for motorists, bicyclists, or pedestrians.

10. Day Care Home.
 - a. Residential Character. The location and operation of the facility may not alter the residential character of the neighborhood, and the facility must incorporate a residential design that is compatible with the surrounding neighborhood.
 - b. Residency of Operator. The day care home must be the primary residence of the operator.
 - c. Employees. Additional nonresident employees are allowed to work in a day care home.
 - d. Minimize Adverse Impacts. The design of the facility must minimize traffic congestion, pedestrian hazards, noise, and other adverse impacts on surrounding properties.
 - e. Home-Based Business Standards. Day care homes are not subject to the home-based business standards of [Section 9.03.C.20 \(Home-Based Business\)](#).

11. Drive-Through Facility.
 - a. Location. In the Mill District, the drive-through window must be located on the interior side or rear façade of the principal structure. In all other zoning districts, the drive-through window may be located on any façade of the principal structure.
 - b. Access. Driveways must comply with the requirements of [Section 10.06 \(Driveways\)](#).
 - c. Stacking Spaces. Stacking spaces must comply with the requirements of [Section 10.07 \(Vehicle Stacking Requirements\)](#).
 - d. Minimum Street Frontage Requirement. Drive-through facilities are exempt from the minimum street frontage requirements established in [Section 8 \(Zoning District Regulations\)](#).
 - e. Minimize Adverse Impacts. The location of entrances and exits must minimize traffic congestion, pedestrian hazards, and adverse impacts on surrounding properties.
 - f. Traffic Study. The Village may require a traffic study to ensure that a proposed development does not adversely affect safe and efficient traffic circulation for motorists, bicyclists, or pedestrians.

12. Elementary, Middle, High, or Vocational School.
 - a. Minimize Adverse Impacts. The location of facilities, entrances, exits, service areas, parking areas, and loading docks must minimize traffic congestion, pedestrian hazards, and adverse impacts on surrounding properties.
 - b. Pedestrian Access. The location of entrances must be designed to allow students and employees to walk or bike to school.

13. Gas Station.
 - a. Minimum Street Frontage Requirement. Gas stations are exempt from the minimum street frontage requirements established in [Section 8 \(Zoning District Regulations\)](#).
 - b. Stacking Spaces. Stacking spaces must comply with the requirements of [Section 10.07 \(Vehicle Stacking Requirements\)](#).
 - c. Canopy Height. The height of a gas station canopy must not exceed 30 feet.
 - d. Traffic Study. The Village may require a traffic study to ensure that a proposed development does not adversely affect safe and efficient traffic circulation for motorists, bicyclists, or pedestrians.
 - e. Light Pollution. Lighting must be designed with luminaires recessed under the canopy to minimize light pollution. The illuminance of the canopy must not exceed 20 foot-candles as measured at any location on the lot.
 - f. Screening. Street frontage not occupied by building or driveways must be improved with landscape screening in accordance with the requirements of [Section 11.05.B \(Parking Lot Perimeter Landscape\)](#).

14. Government Facility. Access. Government facilities are exempt from the maximum driveway widths established in [Section 10.06 \(Driveways\)](#).

15. Indoor Entertainment or Recreation.
 - a. Minimize Adverse Impacts. The location of entrances and exits, service areas, and parking and loading docks must minimize traffic congestion, pedestrian hazards, and adverse impacts on surrounding properties.

- b. Traffic Study. The Village may require a traffic study to ensure that a proposed development does not adversely affect safe and efficient traffic circulation for motorists, bicyclists, or pedestrians.
16. Live/Work Dwelling.
- a. Sales. On-site retail transactions associated with a live/work dwelling are permitted.
 - b. Residency of Operator. The live/work dwelling must be the primary residence of the operator. A portion of a live/work dwelling may be leased as a workspace to an operator that does not reside in the dwelling.
 - c. Employees. Two additional nonresident employees are allowed to work in a live/work dwelling.
 - d. Space Limitation. No more than 50 percent of the total square footage of the dwelling may be used for residential uses.
17. Motor Vehicle Operations Facility or Motor Vehicle Repair and/or Service.
- a. Outdoor Storage. Disabled or inoperable vehicles and those awaiting pick-up may be stored outdoors if the following conditions are met:
 - (1) Location. Outdoor storage of vehicles is prohibited in the front yard and corner side yard.
 - (2) Screening. All storage areas must be screened from view of the street by building and/or landscape screening in accordance with the requirements of [Section 11.05.B \(Parking Lot Perimeter Landscape\)](#).
 - (3) Storage Duration. Motor vehicle repair and/or service facilities must not store the same vehicles outdoors for more than 30 days.
 - b. Location for Repairs. All repairs must occur inside an enclosed building.
 - c. Screening. Street frontage not occupied by buildings or driveways must be improved with landscape screening in accordance with the requirements of [Section 11.05.B \(Parking Lot Perimeter Landscape\)](#).
18. Motor Vehicle Rental or Motor Vehicle Sales.
- a. Screening. The street frontage adjacent to any outdoor sales and display area must be improved with landscape screening in accordance with the requirements of [Section 11.05.B \(Parking Lot Perimeter Landscape\)](#).
 - b. Light Pollution. The illuminance of any outdoor sales and display area must not exceed 10 foot-candles as measured at any location on the lot.
19. Outdoor Dining.
- a. Location. Outdoor dining must be located on private property, unless otherwise allowed by the Village. Outdoor dining must not be located in any yard that is adjacent to a residential use or zoning district, except when such residential use is part of a mixed-use development. Outdoor dining areas must be delineated from the right-of-way and parking areas with masonry walls, planters, bollards, fencing, or similar elements.
 - b. Sidewalk Clearance. A minimum of four feet of sidewalk clearance must remain available for pedestrians in accordance with the Americans with Disabilities Act Accessibility Guidelines.
 - c. Parking Lot Clearance. Outdoor dining must not interfere with the drive aisles and parking spaces of a parking lot.

20. Outdoor Entertainment or Recreation.
 - a. Minimize Adverse Impacts. The location of entrances and exits, service areas, and parking and loading docks must minimize traffic congestion, pedestrian hazards, and adverse impacts on surrounding properties.
 - b. Traffic Study. The Village may require a traffic study to ensure that a proposed development does not adversely affect safe and efficient traffic circulation for motorists, bicyclists, or pedestrians.

21. Outdoor Storage Area.⁵
 - a. Location. Outdoor storage areas must be located on an improved surface in the interior side yard or rear yard. Outdoor storage areas must be located on an improved surface unless an alternative is approved by the Zoning Officer.
 - b. Height. Materials in an outdoor storage area that are 20 feet or less from a lot line must not exceed eight feet in height. Materials in an outdoor storage area that are more than 20 ft from a lot line must not exceed 18 feet.
 - c. Uses. Outdoor storage areas in association with a principal use on the same zoning lot such as but not limited to: garden center, gas station, light manufacturing, heavy manufacturing, machinery and equipment sales and rental, and warehousing, storage or distribution facility. Outdoor storage areas without any other principal use on a zoning lot are only permitted as Special Uses in the M-2 Zoning District.
 - d. Screening. The requirements of [Section 11.07 \(Screening Requirements\)](#) apply to all outdoor storage areas. No stackable materials or goods may be piled or stacked so that they are visible above the height of the screen. The use of slatted chain link fencing around outdoor storage areas may be approved as part of the special use.
 - e. Traffic Study. The Village may require a traffic study to ensure that a proposed development does not adversely affect safe and efficient traffic circulation for motorists, bicyclists, or pedestrians.
 - f. Alternative Surfaces. Crushed aggregate may be installed as an alternative to paved surfaces. Acceptable alternative surfaces include crushed limestone aggregate that meets standard gradation of CA-1 or CA-7, or other materials as approved by the Zoning Officer. The property owner must maintain alternative surfaces and provide periodic dust control measures. The property owner must provide the Village an access easement over all areas utilizing an alternative surface. The alternative surface must be located a minimum of 250 feet from any public right of way and any residential or commercial zoning district.

22. Parking Lot (Primary Use). Screening. The requirements of [Section 11.05.B \(Parking Lot Perimeter Landscape\)](#) apply to all off-street parking lots.

23. Planned Unit Development. Refer to the requirements of [Section 5 \(Planned Unit Developments\)](#).

24. Utility. Screening. The street frontage adjacent to the utility must be treated with landscape screening in accordance with the requirements of [Section 11.05.B \(Parking Lot Perimeter Landscape\)](#).

⁵ Amended per Ordinance 1929.

25. Utility-Scale Solar Energy System.

- a. General Solar Energy System Regulations. The following regulations apply to both principal use and accessory use solar energy systems.
 - (1) Building Permit. All solar energy systems must receive a building permit prior to construction, installation, relocation, or modification. The following items must be submitted as part of the building permit application.
 - (a) Manufacturer's specifications for all equipment.
 - (b) Structural plans that have been signed and sealed by a licensed structural engineer registered in the State of Illinois.
 - (c) A site plan containing the height, location, distance from surrounding lot lines, and a JULIE dig number.
 - (d) A soil conditions report, if panels will be ground-mounted.
 - (2) Wind Resistance. All supporting structures must be rated to withstand wind speeds of 110 miles per hour or greater.
 - (3) Electrical Wiring. All electrical wiring must be located underground or inside the building on which the solar energy system is mounted.
 - (4) Lighting. Solar energy systems must not be artificially illuminated.
 - (5) Signs. No signs are permitted on solar energy systems or supporting structures, with the exception of the manufacturer's safety information and warning signs in accordance with [Section 12.05.A.10 \(Warning Signs\)](#).
 - (6) Contractors. All contractors conducting work on solar energy systems must be licensed with the Village.
 - (7) Utility Interconnection. On-grid solar energy systems must not be installed until documentation has been provided by the utility company agreeing to interconnect with the system. Off-grid solar energy systems are not permitted.
 - (8) Emergency Disconnection.
 - (a) For principal use solar energy systems, an emergency disconnection switch must be provided in an easily-accessible outdoor location.
 - (b) For accessory use solar energy systems, an emergency disconnection switch must be located near the electric meter.
 - (9) Solar Access Easements. Property owners may seek solar access easements from their neighbors and have those easements legally recorded with the applicable county.
- b. Impervious Coverage. Maximum impervious coverage requirements do not apply to utility-scale solar energy systems.

26. Utility-Scale Wind Energy System.

- a. General Wind Energy System Regulations. The following regulations apply to both principal use and accessory use wind energy systems.
 - (1) Building Permit. All wind energy systems must receive a building permit prior to construction, installation, relocation, or modification.
 - (2) Tower Design. All wind energy system towers must be monopoles or latticed with no guyed wires. All wind energy systems must be painted a non-reflective white, off-white, or gray.
 - (3) Electrical Wiring. All electrical wiring must be located underground or inside the building on which the wind energy system is mounted.
 - (4) Lighting. Wind energy systems must not be artificially illuminated, unless required by the Federal Aviation Administration.

- (5) Sound. All wind energy systems must comply with [Section 9.05.A \(Noise\)](#). Noise standards may be temporarily exceeded during severe weather such as tornados and thunderstorms.
 - (6) Signs. No signs are permitted on wind energy systems or supporting structures, with the exception of the manufacturer's safety information and warning signs in accordance with [Section 12.05.A.10 \(Warning Signs\)](#).
 - (7) Contractors. All contractors that perform work on wind energy systems must be licensed with the Village.
 - (8) Utility Interconnection. On-grid wind energy systems must not be installed until documentation has been provided by the utility company agreeing to interconnect with the system. Off-grid systems are not permitted.
 - (9) Emergency Disconnection.
 - (a) For principal use wind energy systems, an emergency disconnection switch must be provided in an easily-accessible outdoor location.
 - (b) For accessory use wind energy systems, an emergency disconnection switch must be located near the electric meter.
 - (10) Clearance. All wind energy systems must have a minimum of 15 feet clearance between the turbine blades and the ground.
 - (11) Access. Any external climbing apparatus associated with a wind energy system must be inaccessible to the public.
- b. Height. The maximum turbine height for utility-scale wind energy turbines is 140 feet.
 - c. Quantity. There is no limit on the quantity of turbines that may be installed in a utility-scale wind energy system.
 - d. Setback. All utility-scale solar energy system towers must be setback a minimum of 1.1 times the tower height from any lot lines, above ground utility lines, and other utility-scale wind turbines.
 - e. Land Cover. Land surrounding turbines in utility-scale wind energy systems must be used for agriculture or open space.
27. Wireless Telecommunication Facility and/or Tower.
- a. General Requirements.
 - (1) Lighting. Wireless telecommunication facilities and towers must not include artificial lighting, unless required by the Federal Communications Commission, the Federal Aviation Administration, or the Village.
 - (2) Signs. Wireless telecommunication facilities and towers must not display signs except for information required for government regulation, such as Federal Communications Commission registration information.
 - (3) Screening. Wireless telecommunication facilities and towers must include landscape screening in accordance with the requirements of [Section 11.06.B \(Buffer Yard Requirements\)](#), except for required fencing, which must be a minimum of eight feet and maximum of 10 feet in height.
 - b. Wireless Telecommunication Facility.
 - (1) Height. The maximum height of a wireless telecommunication facility is 15 feet.
 - (2) Use. Wireless telecommunication facilities may house equipment and supplies for the operation of wireless telecommunication towers. Such facilities must be unstaffed and must be used for equipment that is used as part of the operation of the facility.
 - c. Wireless Telecommunication Tower.

- (1) Height. The maximum height of a wireless telecommunication tower is 50 feet, unless a taller height is required to function satisfactorily; in such case, the applicant must present a report indicating the need for a height in excess of 50 feet.
- (2) Design. Wireless telecommunication towers must be designed to accommodate at least three telecommunication providers and their accompanying wireless telecommunication facilities. Wireless telecommunication towers must have a galvanized gray or silver finish, unless otherwise required by the Federal Communications Commission, the Federal Aviation Administration, or the Village.

9.03 Accessory Uses and Structures

Accessory uses and structures are subject to the requirements of this Section.

A. General Provisions for Accessory Structures.

1. Construction Phasing. No accessory structure may be constructed prior to the construction of the principal building to which it is accessory.
2. Location. Accessory structures may be located in the front, corner side, interior side, and rear yards, unless otherwise established by this Ordinance. Accessory structures are not allowed in any easement, except fences and walls.
3. Setback. Accessory structures must be located a minimum of three feet from any interior lot line or rear lot line, except fences and walls, unless otherwise established by this Ordinance.
4. Height. The maximum height of an accessory structure is (15) feet, unless otherwise established in this Ordinance, as measured to the top of the structure.

B. Accessory Uses and Structures Table. [Table 9.03.1 Accessory Uses and Structures](#) includes accessory uses and structures that may be located in each zoning district within the Village.

1. Allowed (“A”). “A” indicates that the accessory use or structure does not require a building permit and is allowed by-right within the designated zoning district provided that it meets all applicable standards set forth in [Section 9.03.C \(Use Standards for Accessory Use and Structures\)](#).
2. Allowed with Building Permit (“BP”). “BP” indicates that the accessory use or structure requires the approval of a building permit in accordance with [Section 6 \(Buildings and Construction\) of the Municipal Code](#) and must meet the use standards set forth in [Section 9.3.C \(Use Standards for Accessory Uses and Structures\)](#) in order to be allowed within the designated zoning district.
3. No Designation. The absence of a letter (a blank space) indicates that the use or structure is not allowed within the designated zoning district.

Table 9.03.1 Accessory Uses and Structures

Accessory Uses and Structures	A	R-1	R-2	R-3	R-4	R-5	MD	B-1	B-2	M-1	M-2	Use Standards
Accessibility Ramp	BP	BP	BP	BP	BP	BP	BP	BP	BP	BP	BP	None
Accessory Dwelling Unit	BP	BP	BP	BP			BP					See 9.03.C.1
Arbor or Trellis	A	A	A	A	A	A	A	A	A	A	A	None
Awning or Canopy	BP	BP	BP	BP	BP	BP	BP	BP	BP	BP	BP	See 9.03.C.2

Accessory Uses and Structures	A	R-1	R-2	R-3	R-4	R-5	MD	B-1	B-2	M-1	M-2	Use Standards
Balcony	BP	BP	BP	BP	BP	BP	BP	BP	BP	BP	BP	See 9.03.C.3
Ball Court	BP	BP	BP	BP	BP	BP		BP	BP	BP	BP	See 9.03.C.4
Bay Window	BP	BP	BP	BP	BP	BP	BP	BP	BP	BP	BP	See 9.03.C.5
Blue Roof or Green Roof	BP	BP	BP	BP	BP	BP	BP	BP	BP	BP	BP	None
Cabana, Gazebo, or Pergola	BP	BP	BP	BP	BP	BP	BP	BP	BP	BP	BP	See 9.03.C.6
Chimney	BP	BP	BP	BP	BP	BP	BP	BP	BP	BP	BP	See 9.03.C.7
Community Library Kiosk	A	A	A	A	A							See 9.03.C.8
Compost Bin	A	A	A	A	A	A	A	A	A	A	A	See 9.03.C.9
Deck	BP	BP	BP	BP	BP	BP	BP	BP	BP	BP	BP	See 9.03.C.10
Dog Run	A	A	A	A	A	A			S	S		See 9.03.C.11
Eave, Gutter, Sill, or Cornice	BP	BP	BP	BP	BP	BP	BP	BP	BP	BP	BP	See 9.03.C.12
Electrical Generator	BP	BP	BP	BP	BP	BP	BP	BP	BP	BP	BP	See 9.03.C.13
Electric Vehicle Charging Station	BP	BP	BP	BP	BP	BP	BP	BP	BP	BP	BP	None
Fence or Wall	BP	BP	BP	BP	BP	BP	BP	BP	BP	BP	BP	See 9.03.C.14
Flagpole	A	A	A	A	A	A	A	A	A	A	A	See 9.03.C.15
Garage	BP	BP	BP	BP	BP	BP	BP	BP	BP	BP	BP	See 9.03.C.16
Garbage Receptacles and Enclosures	A	A	A	A	A	A	BP	BP	BP	BP	BP	See 9.03.C.17
Garden	A	A	A	A	A	A	A	A	A	A	A	See 9.03.C.18
Greenhouse	BP	BP	BP	BP	BP	BP	BP	BP	BP	BP	BP	See 9.03.C.19
Home-Based Business	A	A	A	A	A	A	A					See 9.03.C.20
Hoophouse	A	A	A	A	A	A	A	A	A	A	A	See 9.03.C.21
Mechanical Equipment	A	A	A	A	A	A	A	A	A	A	A	See 9.03.C.22
Outdoor Fireplace or Fire Pit	BP	BP	BP	BP	BP	BP	BP	BP	BP			See 9.03.C.23
Outdoor Sales and Display Area							A	A	A			See 9.03.C.24
Patio	BP	BP	BP	BP	BP	BP	BP	BP	BP	BP	BP	See 9.03.C.25
Porch	BP	BP	BP	BP	BP	BP	BP	BP	BP			See 9.03.C.26
Rain Barrel or Rainwater Cistern	A	A	A	A	A	A	A	A	A	A	A	None
Rain Garden	A	A	A	A	A	A	A	A	A	A	A	See 9.03.C.27
Recreation Equipment	A	A	A	A	A	A	A	A	A	A	A	See 9.03.C.28
Refuse, Recycling, or Grease Container	A	A	A	A	A	A	A	A	A	A	A	See 9.03.C.29
Satellite Dish	A	A	A	A	A	A	A	A	A	A	A	See 9.03.C.30
Service Walk		A	A	A	A	A	A					See 9.03.C.31
Shed	BP	BP	BP	BP	BP	BP	BP	BP	BP	BP	BP	See 9.03.C.32
Small Wind Energy System (Building-Mounted)	BP	BP	BP	BP	BP	BP	BP	BP	BP	BP	BP	See 9.03.C.33
Small Wind Energy System (Ground-Mounted)	BP								BP	BP	BP	See 9.03.C.34
Solar Energy System (Building-Mounted)	BP	BP	BP	BP	BP	BP	BP	BP	BP	BP	BP	See 9.03.C.35
Solar Energy System (Ground-Mounted)	BP	BP	BP	BP	BP	BP	BP	BP	BP	BP	BP	See 9.03.C.36
Stairs or Stoop	BP	BP	BP	BP	BP	BP	BP	BP	BP	BP	BP	See 9.03.C.37
Swimming Pool or Hot Tub	BP	BP	BP	BP	BP	BP	BP	BP	BP			See 9.03.C.38
Treehouse	BP	BP	BP	BP	BP	BP						See 9.03.C.39
White Roof	A	A	A	A	A	A	A	A	A	A	A	See 9.03.C.40
Wireless Telecommunication Antenna	BP	BP	BP	BP	BP	BP	BP	BP	BP	BP	BP	See 9.03.C.41
Wireless Telecommunication Small Cell	BP	BP	BP	BP	BP	BP	BP	BP	BP	BP	BP	See 9.03.C.42

C. Use Standards for Accessory Uses and Structures. The following standards apply to accessory uses and structures in the Use Standards column of [Table 9.03.1 Accessory Uses and Structures](#).

1. Accessory Dwelling Unit. Accessory dwelling units are subject to approval of site plan review and must meet the following standards.
 - a. Location. Accessory dwelling units are permitted within a principal or accessory structure on zoning lots that contain a single-unit dwelling in the A, R-1, R-2, R-3, or MD Districts. An accessory dwelling unit located in a principal structure may be located anywhere within a principal structure. An accessory dwelling unit located in an accessory structure is allowed in the rear yard only.
 - b. Number. One accessory dwelling unit is permitted per zoning lot.
 - c. Size. The maximum size of an accessory dwelling unit is 900 square feet.
 - d. Design. An accessory dwelling unit must be designed to be clearly secondary to the principal dwelling unit on the site. For accessory dwelling units located in an accessory structure, the exterior materials of the dwelling unit must be compatible with the primary dwelling unit, including siding and trim materials, window design, roof shape, roof pitch, and roof material. Accessory dwelling units must not have axels or wheels.
 - e. Occupancy. On lots with accessory dwelling units, the property owner must maintain permanent residence in either the principal structure or the accessory dwelling unit.
2. Awning or Canopy
 - a. Encroachment. Awnings and canopies may encroach up to four feet into any yard.
 - b. Ground Clearance. Awnings and canopies must have a minimum ground clearance of eight feet.
 - c. Signs. For regulations pertaining to awning and canopy-mounted signs [see Section 12.05.B.2 \(Awning Signs\)](#) and [Section 12.05.B.3 \(Canopy-Mounted Signs\)](#).
3. Balcony.
 - a. Encroachment. Balconies may encroach up to four feet into any yard.
 - b. Ground Clearance. In residential districts, balconies must have a ground clearance of two feet. In non-residential districts, balconies must have a ground clearance of eight feet.
4. Ball Court. Location⁶. Ball courts are allowed in the rear yard, except that one fixed basketball standard and backboard are allowed in the front yard, corner side yard, interior side yard, or rear yard in the R-1, R-2, R-3, R-4, and R-5 Districts without a building permit. Fixed basketball standards and backboards must be located in a driveway and must be located at least six feet from any sidewalk and five feet from any lot line.
5. Bay Window. Encroachment. Bay windows may encroach up to three feet into any yard.
6. Cabana, Gazebo, or Pergola.
 - a. Location. Cabanas and gazebos are allowed in the rear yard only. Pergolas are allowed in the front, corner side, interior side, and rear yards.
 - b. Number. A zoning lot may have two of either a cabana, gazebo, or pergola.
 - c. Size. A cabana, gazebo, or pergola may be a maximum of 350 square feet.
 - d. Design. Each side of a gazebo must be at least 25 percent open.
7. Chimney. Encroachment. Chimneys may encroach up to three feet into any yard.

⁶ Amended per Ordinance 1929.

8. Community Library Kiosk.
 - a. Registration Required. Prior to installation, all community library kiosks must be registered with the Village's Community Development Department with a designated sponsor that is responsible for their maintenance, repair, and replacement.
 - b. Location. Community library kiosks may be located in the front or corner side yards. A community library kiosk may also be located in a rear yard if the yard is adjacent to a community bike path.
 - c. Size. The enclosed area used for storing books and reference materials may be no larger than 24 inches on any side.
 - d. Design. Community library kiosks must be constructed on a single post and securely attached.
 - e. Maintenance. All community library kiosks must be maintained in a state of structural integrity and good repair, for example free from peeling paint and rotting wood.
9. Compost Bin.
 - a. Location. Compost bins are allowed in the rear yard only.
 - b. Enclosure. Compost must be contained in a fully enclosed receptacle with a tightly fitted lid.
 - c. Maintenance. Compost bins must be maintained in a sanitary condition so as not to become a nuisance. Compost must not contain sewage, meat, bones, or grease.
10. Deck. Location. Uncovered decks are allowed in the interior side yard or rear yard. Covered decks are allowed only in the rear yard.
11. Dog Run.
 - a. Location. Dog runs may be located in the rear yard only.
 - b. Coverage. Dog runs must be uncovered in R-1, R-2, R-3, R-4, and R-5 Districts.
 - c. Size. Dog runs must not exceed 48 square feet in R-1, R-2, R-3, R-4, and R-5 Districts. Any dog run exceeding 48 sq. ft. must meet the standards set forth in [Section 9.03.C.14 \(Fence or Wall\)](#).
12. Eave, Gutter, Sill, or Cornice. Encroachment. Eaves, gutters, sills, and cornices may encroach up to three feet into any yard.
13. Electrical Generator. Location. Electrical generators may be located in the interior side and rear yard only.

14. Fence or Wall.⁷

- a. Height. [Table 9.03.2 Maximum Fence Height](#) provides maximum height requirements for fences or walls by zoning district. Maximum fence heights shown are for both open fence and solid fence designs, unless otherwise noted. The maximum height of a fence or wall is measured from the ground at the base of the fence or wall.

Table 9.03.2 Maximum Fence Heights

Zoning District	Yard	Maximum Fence Height
R-1, R-2, R-3, R-4, R-5	Front	3 ft for solid designs 4 ft for open designs
	Corner Side	4 ft. 6 ft. if set back a minimum of 10 ft. from corner side lot line
	Interior Side	6 ft adjacent to residential districts 8 ft adjacent to non-residential districts
	Rear	6 ft adjacent to residential districts 8 ft adjacent to non-residential districts
MD, B-1, B-2	Front	3 ft for solid designs 4 ft for open designs
	Corner Side	3 ft for solid designs 4 ft for open designs
	Interior Side	6 ft adjacent to non-residential districts 8 ft adjacent to residential districts
	Rear	6 ft adjacent to non-residential districts 8 ft adjacent to residential districts
A, M-1, M-2	All Yards	8 ft
All Zoning Districts	Yard	Maximum Fence Height
Parks and Schools	All Yards	8 ft
Utilities	All Yards	15 ft

- b. Access. Every fence with frontage on a right-of-way, except for corner lots, must include a gate that provides access to the right-of-way.
- c. Construction, Design, and Appearance. In all zoning districts, both sides of a fence or wall must be similar in construction, design, and appearance. The finished side of a fence or wall must face outward from the zoning lot so that all posts are located on the property owner's side of the fence or wall.
- (1) Residential Districts. In residential zoning districts, fences and walls may only be constructed of treated wood, simulated wood, vinyl, decorative metal, brick, and stone. In addition, parks and schools may also utilize vinyl coated chain link.
 - (2) Non-Residential Districts. In non-residential zoning districts, fences and walls may only be constructed of treated wood, simulated wood, vinyl-coated chain link, metal mesh, corrugated metal, decorative metal, brick, stone, cinderblock, and concrete block unless otherwise approved as part of a special use.
 - (3) Specific Materials.

⁷ Amended per Ordinance 1929.

- (a) Electrically charged security alarm fences are allowed. Electrically charged stun/lethal fences are prohibited.
- (b) Fences may only be constructed of barbed wire or razor wire in the M-1 and M-2 Districts where barbed wire may be used with an approved building permit. Approved barbed wire fences may have a maximum of three strands of barbed wire. Fences may only be constructed of barbed wire or razor wire in the M-1 and M-2 Districts where barbed wire may be used with an approved building permit. Approved barbed wire fences may have a maximum of three strands of barbed wire.
- d. Plastic snow fences may be used on a temporary basis during times of snow cover at the discretion of the Zoning Officer. Annexation Agreements. A comprehensive list of fence regulations for neighborhoods with active annexation agreements is available from the Zoning Officer.

15. Flagpole.

- a. Location. Flagpoles must be located at least 5 feet from the lot line.
- b. Number. A maximum of three flag poles are allowed per zoning lot
- c. Height. The maximum height of a flagpole is 30 feet in residential districts and 40 feet in non-residential districts.

16. Garage.

- a. Single-Unit, Two-Unit, and Townhome Dwellings. Refer to [Figure 9.03.1 Garage Location for Single-Unit, Two-Unit, and Townhome Dwellings](#).
 - (1) Attached Garage Location. Attached garages may be attached to the corner side, interior side, or rear elevation of the principal structure. Attached garages with a front-facing garage must be set back a minimum of five feet from the front elevation of the principal structure.
 - (2) Detached Garage Location. Detached garages are allowed in the rear yard.
 - (3) Number. One attached and one detached garage are allowed per dwelling unit.
 - (4) Size. For zoning lots less than 20,000 sf, the maximum cumulative size of an attached and/or detached garage is 880 square feet. For zoning lots 20,000 sf or greater, the maximum cumulative size of an attached and/or detached garage is 1,100 square feet; the garage shall not be larger than the building footprint of the principal structure.
- b. Multiple-Unit Dwellings. The exterior materials of a garage accessory to a multiple-unit dwelling must be compatible with the principal building. A garage accessory to a multiple-unit dwelling must have varied roofline.
- c. Alley Orientation. Where an alley exists adjacent to the side or rear lot line, all motor vehicle access to a garage must occur through the alley.

Figure 9.03.1 Garage Location for Single-Unit, Two-Unit, and Townhome Dwellings

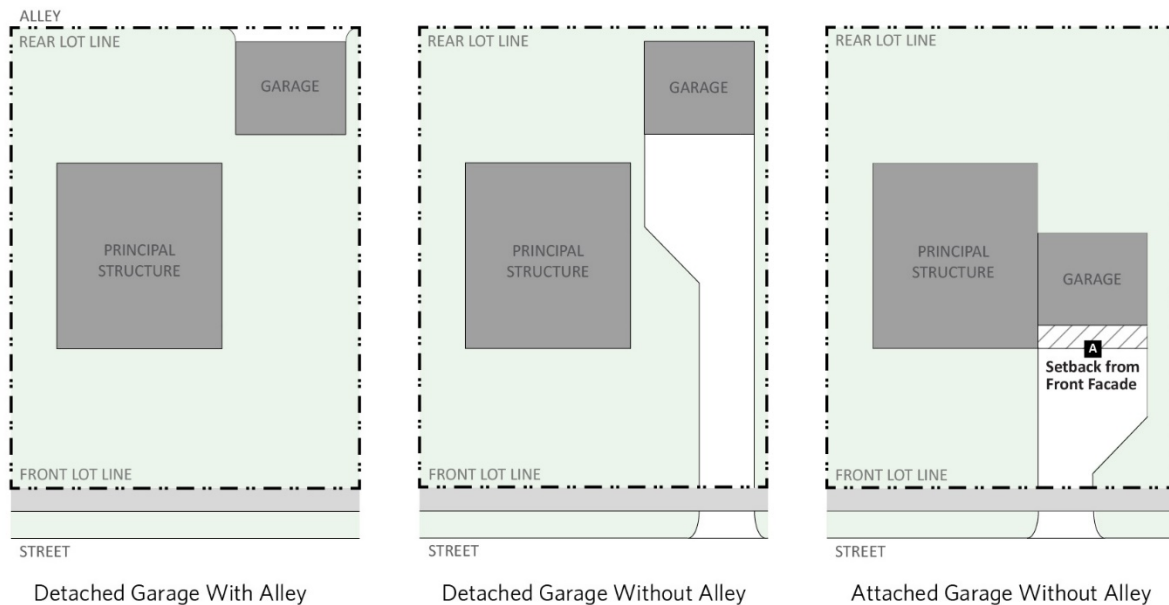

17. Garbage Receptacles and Enclosures.

- a. Location. Garbage receptacles and enclosures are allowed in the interior side and rear yards
- b. Screening. Garbage receptacles and enclosures in the MD, B-1, and B-2 Districts must be screened in accordance with [Section 11.07.B \(Refuse Area, Ground-Mounted Mechanical Equipment, Ground-Mounted Utility, and Outdoor Storage Area Screening Requirements\)](#).

18. Garden.

- a. Size. Gardens must be limited to 50 percent of the pervious area of the front yard and corner side yard. There are no size limitation for gardens in the interior side yard and rear yard.
- b. Height. The maximum height of any structure used to grow items in a garden, such as raised planting beds or hoopouses, is three feet in the front or corner side yard, and six feet in the interior side or rear yard.
- c. Loose Soil. Loose soil associated with a garden must be covered or confined so that the soil does not spillover from the garden area.

19. Greenhouse.

- a. Location. Greenhouses are allowed only in rear yards in the A, R-1, R-2, R-3, R-4, and R-5 Districts.
- b. Size. Greenhouses are limited to a maximum size of 200 square feet.

20. Home-Based Business.

- a. Location. A home-based business is permitted within any dwelling unit in the Village as part of a principal or accessory building in accordance with the following standards. Home-based business standards do not apply to day care homes which are regulated in accordance with the requirements of [Section 9.02.B.10 \(Day Care Home\)](#).
- b. Residential Character. The location and operation of a home-based business must not alter the residential character of the dwelling or neighborhood.

- c. Uses. Examples of allowed home-based business include, but are not limited to, artist, consultant, counselor, craftsman, designer, tutor, writer, and instructor of music, craft, or fine art.
 - d. Sales. No on-site retail or wholesale transactions are allowed.
 - e. Hours of Operation. Home-based businesses with outside visitors may operate from 7:00 AM to 9:00 PM.
 - f. Residency of Operator. The operator of the home-based business must reside in the dwelling unit in which the home-based business is located.
 - g. Employees. One additional employee who does not reside in the dwelling unit is allowed to work in a home-based business.
 - h. Visitors. A maximum of four visitors (such as clients, customers, and pupils) associated with the home-based business may be present at any given time.
 - i. Parking. Any parking needs associated with the home-based business must be accommodated on-site within an existing driveway or garage.
 - j. Deliveries. Deliveries and shipments are not allowed to or from the premises, with the exception of carriers that typically provide service to residential neighborhoods, such as the U.S. Postal Service and/or express shipping services (e.g. UPS, FedEx, DHL).
 - k. Signs. Signs for home-based businesses are permitted in accordance with [Section 12.05.A \(Permanent Signs Allowed Without a Sign Permit\)](#).
21. Hoophouse.
- a. Use Limitation. Hoophouses are only allowed in conjunction with agricultural uses, community gardens, and garden centers.
 - b. Size. Greenhouses are limited to a maximum size of 200 square feet.
22. Mechanical Equipment.
- a. Location. Ground-mounted mechanical equipment may only be located in the interior side yard or rear yard. Roof-mounted mechanical equipment must be located a minimum of six feet from the edge of the supporting walls of any roof.
 - b. Screening. Roof-mounted mechanical equipment screening must equal the height of the tallest mechanical equipment installed on the roof of the building. The requirements of [Section 11.07 \(Screening Requirements\)](#) apply to ground-mounted mechanical equipment.
23. Outdoor Fireplace or Fire Pit.
- a. Location. Outdoor fireplaces and fire pits are allowed in the rear yard only.
 - b. Setback. Outdoor fireplaces and fire pits must be located a minimum of 10 feet from any building.
 - c. Size. The maximum diameter of outdoor fireplaces and fire pits is four feet.
24. Outdoor Sales and Display Area.
- a. Items Offered. The items permitted to be offered in outdoor sales and display areas include, but are not limited to, building or garden supplies for retail sale, nursery plants, equipment for household use, and other household items that are typically used or stored outdoors. Permanent outdoor sales and display areas for motor vehicle sales are subject to the requirements for [Section 9.02.B.18 \(Motor Vehicle Rental or Motor Vehicle Sales\)](#).
 - b. Size. Outdoor sales and display areas must not exceed 15 percent of the gross lot area in commercial zoning districts and 25 percent in industrial zoning districts.
 - c. Improved Surface. Outdoor sales and display areas must be paved.

- d. Access. Outdoor sales and display areas must not obstruct driveways, parking areas, sidewalks, and landscaped yards.
 - e. Fencing. If an outdoor sales and display area is secured with a fence, it must be constructed of treated wood, simulated wood, and decorative metal.
25. Patio. Location. Open patios are allowed in the interior side yard or rear yard. Permanently roofed patios are allowed only in the rear yard.
26. Porch. Location. Porches must be located at least five feet from a lot line, and may project a maximum of eight feet from a structure.
27. Rain Garden.
- a. Loose Soil. Loose soil associated with a rain garden must be covered or confined so that the soil does not spill over from the garden area.
 - b. Prairie Grass Permit. Prairie grasses planted within rain gardens must comply with Chapter 9, Article V. Prairie Grasses Control of the Village Code.
28. Recreation Equipment. Location. Recreation equipment is allowed in the rear yard only.
29. Refuse, Recycling, and Grease Containers.
- a. Applicability. Refuse, recycling, and grease container regulations apply only to those uses that collect refuse, recyclable materials, and grease in commercial containers.
 - b. Location. Refuse, recycling, and grease containers are prohibited in the front yard.
 - c. Screening. The requirements of [Section 11.07 \(Screening Requirements\)](#) applies to refuse, recycling, and grease containers.
30. Satellite Dish. Location. Ground-mounted satellite dishes and antennas are allowed in the rear yard. Building-mounted satellite dishes and antennas are allowed on the rear or interior side yard façade of a building or on the roof of a building.
31. Service Walk. Size. A service walk must be a minimum of three feet in the R-1, R-2, and R-3 Districts, and five feet in the R-4, R-5 and M-D Districts.
32. Shed.
- a. Location. Sheds are allowed only in rear yards.
 - b. Number. One shed is allowed per zoning lot.
 - c. Area⁸. In the R-1, R-2, R-3, and R-5 Districts, the maximum area of a shed is 200 square feet.
 - d. Motor Vehicle Storage. The storage of motor vehicles, including, but not limited to, cars, trucks, and vans, in sheds is prohibited.
33. Small Wind Energy System (Building-Mounted)
- a. General Wind Energy System Regulations. All building-mounted small wind energy systems must comply with the general wind energy system regulations in [Section 9.02.B.26.a \(General Wind Energy System Regulations\)](#). Refer to [Figure 9.03.2 Small Wind Energy System \(Building-Mounted\)](#).

⁸ Amended per Ordinance 1929.

- b. Quantity.
 - (1) In the R-1, R-2, R-3, R-4, and R-5 Districts, one building-mounted small wind energy system is permitted per zoning lot.
 - (2) In the MD, B-1, B-2, A, M-1, and M-2 Districts, there is no maximum number of building-mounted small wind energy systems per zoning lot.
- c. Location. Building-mounted small wind energy systems may be attached to the any portion of a flat-roofed building, or to the roof or walls of the rear 50 percent of a principal building.
 - (1) In the R-1, R-2, R-3, R-4, and R-5 Districts, building-mounted wind energy turbines may be attached to the roof or walls of the rear 50 percent of the principal building.
 - (2) In the MD, B-1, B-2, A, M-1, and M-2 Districts, building-mounted wind energy turbines may be attached to any portion of the roof of a flat roofed building or to roof or walls of the rear 50 percent of a pitched roof building.
- d. Setbacks. All building-mounted small wind energy systems must be setback a minimum of 1.1 times the turbine height from any lot lines, above ground utility lines, or tower-mounted wind energy turbines.
- e. Height. Building-mounted small wind energy systems may extend no more than 10 feet above the height of the building's roofline.
- f. Turbine Certification. All small wind energy systems must be approved by a small wind turbine certification program recognized by the American Wind Energy Association.

Figure 9.03.2 Small Wind Energy System (Building-Mounted)

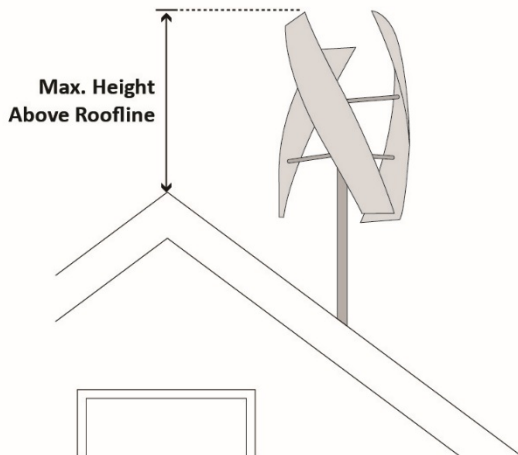

- 34. Small Wind Energy System (Ground-Mounted)
 - a. General Wind Energy System Regulations. All ground-mounted small wind energy systems must comply with the general wind energy system regulations in [Section 9.02.B.26.a \(General Wind Energy System Regulations\)](#). Refer to [Figure 9.03.3 Small Wind Energy System \(Ground-Mounted\)](#).
 - b. Location. Ground-mounted small wind energy systems are allowed only in the rear yard.
 - c. Setbacks. All ground-mounted small wind energy systems must be setback a minimum of 1.1 times the turbine height from any lot lines, above ground utility lines, or tower-mounted wind energy turbines.

- d. Height. The maximum turbine height for a ground-mounted small wind energy system is the maximum building height of the zoning district in which the turbine is located.
- e. Turbine Certification. All small wind energy systems must be approved by a small wind turbine certification program recognized by the American Wind Energy Association.

Figure 9.03.3 Small Wind Energy System (Ground-Mounted)

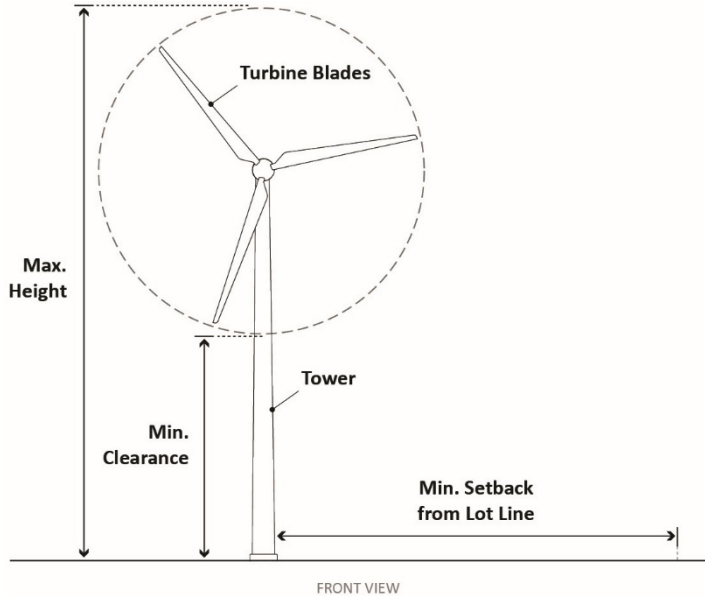

35. Solar Energy System (Building-Mounted)

- a. General Solar Energy System Regulations. All building-mounted solar energy systems must comply with the general solar energy system regulations detailed in [9.02.B.25.a \(General Solar Energy System Regulations\)](#). Refer to [Figure 9.03.4 Solar Energy System \(Building-Mounted\)](#).
- b. Location. Building-mounted solar energy systems may be installed on principal or accessory structures in any district. Building-mounted solar energy systems located on a roof must not extend beyond the edge of the building's roof.
- c. Height. Building-mounted solar energy systems may be a maximum of one foot taller than the highest point of the building's roofline.
- d. Roof Coverage.
 - (1) Pitched Roof. A building-mounted solar energy system may cover 60 percent of a pitched roof.
 - (2) Flat Roof. There is no coverage limit for building-mounted solar energy systems on flat roofs.
- e. Roof Vents. Building-mounted solar energy systems must not be located within six inches of a roof vent.
- f. Solar Hot Water Systems. Solar hot water systems may be mounted on pitched and flat roofs.

Figure 9.03.4 Solar Energy System (Building-Mounted)

Panels Must Not Extend Vertically Above Roof Ridge

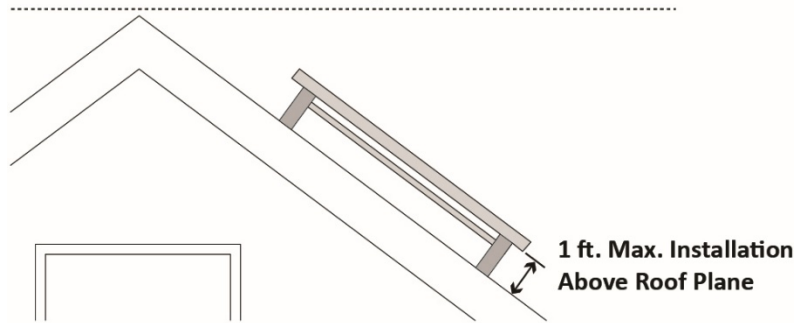

36. Solar Energy System (Ground-Mounted)
 - a. General Solar Energy System Regulations. All ground-mounted solar energy systems must comply with the general solar energy system regulations detailed in [Section 9.02.B.25.a \(General Solar Energy System Regulations\)](#).
 - b. Location. Ground-mounted solar energy systems are allowed in the rear yard of any zoning district.
 - c. Height. The maximum height of ground-mounted solar energy systems is 12 feet.
37. Stairs or Stoop. Encroachment. Stairs and stoops may encroach up to five feet into any yard.
38. Swimming Pool or Hot Tub. The following standards apply to swimming pools and hot tubs, with a depth equal to or greater than two feet.
 - a. Location. Swimming pools and hot tubs are allowed in the rear yard.
 - b. Height. Aboveground swimming pools and hot tubs must not exceed six feet in height.
 - c. Distance from Other Structures. A swimming pool or hot tub must be a minimum of three feet from any other structure or building on a zoning lot, with the exception of a permanent deck or patio. A swimming pool must be at least five feet from any buried utility lines or cables and 10 feet from any aerial utility lines or cables, as verified by the Zoning Officer.
39. Treehouse.
 - a. Location. Treehouses are allowed in the rear yard.
 - b. Number. A maximum of one treehouse is allowed per zoning lot.
 - c. Size. The maximum size of a treehouse is 100 square feet.
 - d. Tree Incorporation. Treehouses must incorporate a planted tree as a critical structural element.
40. White Roof. Roof Types. White roofs are permitted on flat roofs in all districts, but must not be used on pitched roofs.
41. Wireless Telecommunication Antenna.
 - a. General Requirements. Wireless telecommunication antennas must meet the general requirements for wireless telecommunication facilities and/or towers in [Section 9.02.B.27.a \(General Requirements\)](#).
 - b. Height. A wireless telecommunication antenna must not increase the height of any building, structure, or wireless telecommunication tower on which it is mounted by more than 10 percent.

- c. Stealth Design. All wireless telecommunication antennas must utilize stealth design to blend into the structure upon which it is mounted, such as a rooftop, tower, spire, or other similar feature, including those co-located on a wireless telecommunication tower. A wireless telecommunication antenna must be enclosed, camouflaged, screened, or obscured so that it is not readily apparent to a casual observer.

42. Wireless Telecommunication Small Cell. Installation Requirements. Wireless telecommunication small cells must be installed in accordance with the requirements of Chapter 17, Article IV (Small Wireless Facilities), as may be amended from time to time.

9.04 Temporary Uses and Structures

Temporary uses and structures are subject to the requirements of this section.

A. Temporary Uses and Structures Table. [Table 9.05.1 Temporary Uses and Structures](#) establishes the allowed temporary uses and structures for each zoning district. [Table 9.05.1. Temporary Uses and Structures](#) is not an exhaustive list of temporary uses and structures that may be located within the Village. Each use or structure is given one of the following designations for each zoning district.

1. Allowed (“A”). “A” indicates that the temporary use or structure does not require a temporary use permit and is allowed by-right within the designated zoning district provided that it meets all applicable use standards set forth in [Section 9.05.B \(Use Standards for Temporary Uses and Structures\)](#).
2. Allowed with Temporary Use Permit (“TUP”). “TUP” indicates that the temporary use or structure requires the approval of a temporary use permit (refer to [Section 4.10 \(Temporary Use Permit\)](#)) and must meet any applicable use standards set forth in [Section 9.05.B \(Use Standards for Temporary Uses and Structures\)](#) in order to be allowed within the designated zoning district.
3. No Designation. The absence of a letter (a blank space) indicates that the use is not allowed within the designated zoning district.

Table 9.05.1 Temporary Uses and Structures

Temporary Uses and Structures	A	R-1	R-2	R-3	R-4	R-5	MD	B-1	B-2	M-1	M-2	Use Standards
Construction Trailer	A	A	A	A	A	A	A	A	A	A	A	See 9.05.B.1
Farmers Market	TUP	TUP	TUP	TUP	TUP	TUP	TUP	TUP	TUP			See 9.05.B.2
Garage or Yard Sale	A	A	A	A	A	A	A					See 9.05.B.3
Mobile Food Facility							TUP	TUP	TUP	TUP	TUP	See 9.05.B.4
Model Unit	A	A	A	A	A	A	A					See 9.05.B.5
Temporary Outdoor Entertainment	TUP	TUP	TUP	TUP	TUP	TUP	TUP	TUP	TUP	TUP	TUP	See 9.05.B.6
Temporary Outdoor Sale	TUP						TUP	TUP	TUP			See 9.05.B.7
Temporary Storage Container	A	A	A	A	A	A	A	A	A	A	A	See 9.05.B.8

B. Use Standards for Temporary Uses and Structures. The following standards apply to temporary uses and structures designated as permitted (“P”) or permitted with temporary use permit (“T”) in the zoning districts noted in the “Use Standards” column of [Table 9.05.1 Temporary Uses and Structures](#). Temporary uses may be located outdoors or within an enclosed building or structure.

1. Construction Trailer. Duration. Construction trailers are limited to the period of active construction of the project. Construction trailers must not contain accommodations for sleeping or cooking.
2. Farmers Market.
 - a. Schedule. The schedule and duration of a farmers market will be determined as part of a temporary use permit. A temporary use permit for a farmers market can be issued on an annual basis, which allows for a schedule of days per week and number of weeks per year.
 - b. Management Plan. A management plan that demonstrates the following must be submitted.
 - (1) The on-site presence of a manager to direct the operation of vendors.
 - (2) An established set of operating rules, days and hours of operation, vendor set-up and take-down times, a maintenance plan, and provisions for waste removal.
 - (3) A site plan indicating vendor stalls, visitor facilities, seating areas, restrooms, parking, and all entrances and exits to the site.
3. Garage or Yard Sale.
 - a. Eligibility. Only residential properties may hold garage or yard sales.
 - b. Frequency. Garage and yard sales may be held for a three-day period twice per year. Village-wide garage and yard sales do not count toward this total.
4. Mobile Food Facility.
 - a. Location. A mobile food facility must be located at least 50 feet from a single-unit dwelling or multiple unit dwelling. This does not include single-unit dwelling and multiple-unit dwellings that are part of mixed-use developments.
 - b. Number. One mobile food facility is allowed per zoning lot.
 - c. Access. A mobile food facility must provide access to driveways, fire lanes, and required parking spaces.
 - d. Temporary Structures. Mobile food facilities must not sell items from temporary structures.
 - e. Signs. Signs must be located only on the surface of the vehicle and all signs must be in accordance with [Section 12 \(Signs\)](#).
 - f. Hours of Operation. A mobile food facility may operate only between the hours of 6:00 AM and 11:00 PM.
 - g. Permitted Items. Mobile food facilities may only sell food and beverage items.
 - h. Daily Removal. Mobile food facilities must be removed from the site on a daily basis.
 - i. Maintenance. The permit holder for a mobile food facility must keep the area clear of litter and debris during business hours and provide a trash receptacle for customer use if such receptacles are not already provided on site or in the right-of-way.
 - j. Outdoor Seating. Outdoor seating may be provided on site, but no seating may be permanently installed.
 - k. Electrical Service. Electrical service may be provided only by temporary service through an electric utility or by an on-board generator.
 - l. Water Connection. A permanent water or wastewater connection is prohibited.
 - m. Drive-Throughs. Drive-through service is prohibited.
 - n. Mobile Food Facility Permits.
 - (1) Number of Permits. The number of permits available for mobile food facilities will be set by resolution of the Village Board. If a resolution is not passed, or it is later repealed, then the number of mobile food facility permits will be zero. An applicant may petition the Village

- Board to increase the number of permits available if no permit is available at the time of application. The applicant may petition the Village Board to increase the number of permits by submitting a letter of intent and appearing before the Village Board to change the resolution that sets the number of permits.
- (2) Permit Standards. Mobile food facilities must obtain a permit for each location where sales take place. Mobile food facility permits are valid for one year from the date of issuance. Permit renewals are allowed annually and are processed by the Zoning Officer. Each permit holder is allowed a maximum of two permits.
 - (3) Site Authorization. A mobile food facility permit must annually submit written authorization from the property owner to occupy the site where the mobile food facility will operate.
 - (4) Health Department Permit. A mobile food facility must annually submit a permit from the health department of the appropriate county.
 - (5) Permit Fee. Mobile food facility permits have an annual fee of \$100.
5. Model Unit. Duration. Model units are permitted only during the period of active selling and/or leasing of space in a development. Model units must not be used for sleeping, bathing, or cooking purposes.
6. Temporary Outdoor Entertainment.
- a. Duration. Temporary outdoor entertainment is limited to a period of seven consecutive days.
 - b. Frequency. A maximum of two temporary outdoor entertainment permits may be issued per year for any zoning lot.
 - c. Other Local Regulations. Temporary outdoor entertainment must comply with the requirements of the [Municipal Code \(see Chapter 3 ½, Article II Carnivals\)](#) and other local regulations.
 - d. Temporary Use Permit Application. Approval of the temporary use permit is based on the adequacy of the lot area, provision of parking, traffic access, and public safety, as well as the absence of undue adverse impacts on adjacent properties. The temporary use permit application must include the following:
 - (1) Site Plan. As part of a temporary use permit application, the operator of the event must submit a site plan to the Village prior to the event that illustrates the location of major site components and ingress and egress routes for emergency vehicles.
 - (2) Proof of State Inspection. The operator of the event must provide proof that all amusement devices have been inspected and approved by the State of Illinois Department of Labor.
 - e. Bulk and Setback Requirements. Temporary outdoor entertainment is exempt from the bulk and setback requirements of [Section 8 \(Zoning District Regulations\)](#).
 - f. Live Musicians. Approved outdoor dining uses in accordance with [Section 9.02.B.19 \(Outdoor Dining\)](#) may allow live musicians to perform for guests in the outdoor dining area.
7. Temporary Outdoor Sale.
- a. Duration. Temporary outdoor sale uses are limited to a period of up to 45 days. The Zoning Officer may grant additional time or successive permits through the temporary use permit process.
 - b. Temporary Use Permit Application. Approval of a temporary use permit for a temporary outdoor sale is based on the adequacy of the lot area, provision of parking, traffic access, and public safety, as well as the absence of adverse impacts on other properties.

- c. Sidewalk Clearance. A minimum of four feet of sidewalk clearance must remain available for pedestrians in accordance with the Americans with Disabilities Act Accessibility Guidelines.
 - d. Storage. Merchandise must be stored inside the building during non-business hours where practical.
8. Temporary Storage Container.
- a. Duration. Temporary storage containers must be located on a lot for a period of no more than 30 consecutive days unless used in conjunction with an approved building permit.
 - b. Frequency. A maximum of two instances of temporary storage container installation are allowed per year.
 - c. Improved Surface. The temporary storage container must be located on an improved surface. Containers must not be permanently attached to the ground, have permanent utility service, or be stacked on top of one another.

9.05 Environmental Performance Standards

All uses in all zoning districts must comply with the performance standards established in this Section, unless any federal, state, county, or local regulations establish a more restrictive standard, in which case the more restrictive standard applies.

- A. Noise. No activity or use may be conducted in a manner that generates a level of sound, as measured on another property, greater than that allowed by federal, state, county, and local regulations. These limits do not apply to construction noises, noises emanating from safety signals or warning devices, noises not directly under the control of the owner or occupant of the property, and transient noises from moving sources, such as motor vehicles, railroads, and aircraft.
- B. Odor. No activity or use may be conducted in a manner that generates odors of such intensity and character as to be harmful to the health, welfare, or comfort of the public. Any such use must be stopped or modified so as to remove the odor.
- C. Dust and Air Pollution. Dust and air pollution carried by the wind from sources such as storage areas, yards, parking areas, equipment, and the like, within lot boundaries, must be kept to a minimum by appropriate landscaping, screening, paving, wetting, or other acceptable means.
- D. Glare and Heat. No activity or use may be conducted in a manner that generates glare or heat that may be detected at any point off the lot on which the use is located. Light sources must be shielded so as not to cause a nuisance across lot lines.
- E. Vibration. No activity or use may be conducted in a manner that generates earthborn vibration that can be detected at any point off the lot on which the use is located.
- F. Fire and Explosion Hazards. Materials that present potential fire and explosion hazards must be transported, stored, and used only in conformance with all applicable federal, state, county, and local regulations.
- G. Electromagnetic Interference. Electromagnetic interference from the operation of any use that is not in compliance with the rules and regulations of the Federal Communications Commission must not adversely affect the operation of any equipment located off the lot on which such interference originates.

H. Hazardous, Radioactive, and Toxic Materials. No activity or use may produce hazardous, radioactive, or toxic material without prior notice to the Village. Notice must be given to the Zoning Officer at least 30 days before the operation is commenced. The transport, handling, storage, discharge, clean up, and disposal of all hazardous, radioactive, or toxic materials, including waste, must comply with applicable federal, state, county, and local regulations.

SECTION 10: OFF-STREET PARKING AND LOADING

[10.01 General Provisions](#)

[10.02 Off-Street Parking Spaces](#)

[10.03 Bicycle Parking](#)

[10.04 Parking Design Standards](#)

[10.05 Pedestrian Circulation Systems](#)

[10.06 Driveways](#)

[10.07 Vehicular Stacking Requirements](#)

[10.08 Recreational Vehicle Parking](#)

[10.09 Off-Street Loading Facility Requirements](#)

10.01 General Provisions

- A. Purpose. The purpose of this Section is to promote the health, safety, and general welfare of the public by providing for safe and efficient traffic circulation, ensuring an appropriate quantity of vehicular and bicycle parking to support a variety of land uses, and minimizing impervious surface coverage associated with parking and loading.
- B. Applicability. The requirements of this Section apply to the following:
1. New construction of a principal structure or principal use.
 2. Alteration of an existing principal structure or a change in principal use that results in an increase in the number of parking spaces.
 3. The construction of new parking facilities, loading facilities, drive-throughs, and/or driveways.
 4. The reconfiguration, expansion, or reconstruction of existing parking facilities, loading facilities, drive-throughs, and/or driveways.
- C. General Requirements. The following requirements apply to all parking and loading areas.
1. Site Plan Review Approval. Site plan review approval is required prior to either the construction of a new parking lot, resurfacing of a parking lot, or the expansion of an existing parking lot (see [Section 4.02 \(Site Plan Review\)](#)).
 2. Occupancy Permit. Construction of off-street parking lots and loading areas required by this Section must be completed prior to the issuance of an occupancy permit for the uses served by the parking and loading facilities.
 3. Change in Use. When an existing use is changed to a new use, parking and loading spaces may be increased or decreased for the new use with an approved occupancy permit.
 4. Encroachment. Parking facilities are allowed to encroach into the required front yard, corner side yard, interior side and/or rear yard, but must be at least one foot from any lot line, provided no

parking lot perimeter landscape (see [Section 11.05.B \(Parking Lot Perimeter Landscape\)](#)) or buffer yard (see [Section 11.06 \(Buffer Yards\)](#)) is required.

5. Maintenance Responsibility. All parking and loading facilities must be maintained and kept in good repair by the property owner.
6. Montgomery Engineering Design Manual. All parking and loading areas must be improved according to the requirements of the Montgomery Engineering Design Manual.

10.02 Off-Street Parking Spaces

A. General Requirements. Off-street parking spaces for motor vehicles must be provided in accordance with the following standards.

1. Availability of Spaces. All parking spaces approved as part of an approved occupancy permit must be made available to the users of the principal use. Spaces must not be utilized for motor vehicle repair, service, or for long-term storage or display of vehicles, materials, or goods.
2. Accessible Parking.
 - a. State Requirements. Accessible parking spaces must be designed and provided as required by the Illinois Accessibility Code and all additional applicable laws.
 - b. Applicability. Accessible parking must be provided for all off-street parking lots that provide parking for employees and/or visitors with the exception of single-unit and two-unit dwellings.
 - c. Minimum Parking Requirements. The number of accessible parking spaces are counted toward the total number of off-street parking spaces required.
3. Off-Premises Parking Facilities. Parking facilities for uses other than single-unit, two-unit, and townhouse dwellings may be provided off-premises with prior written approval by the Zoning Officer provided that the following conditions are met:
 - a. Residential Uses. Any off-premises parking facility for a multi-dwelling unit must be located within 300 feet, along a pedestrian route, of the nearest principal entrance of the building for which the parking facilities are required.
 - b. Non-residential Uses. Any off-premises parking facility for a non-residential use must be located within 1,000 feet, along a pedestrian route, of the nearest principal entrance of the building for which the parking facilities are required.
 - c. Off-Premises Facility Agreement. A written agreement for off-premise parking facilities must be executed between the property owner and the lessee to guarantee that off-street parking spaces will be provided for the uses served for as long as such uses are in operation. The agreement must be in a format satisfactory to the Village Attorney and must be recorded in the Office of the Recorder of Deeds of Kane or Kendall County, as applicable.
4. Tandem Parking. Tandem parking may be granted by the Zoning Officer for residential uses only through an application for Site Plan Review (see [Section 4.02 \(Site Plan Review\)](#)). Both parking spaces must be allotted to the same dwelling unit and located on the same lot as the dwelling unit.

5. Garage Parking for Single-Unit, Two-Unit, and Townhouse Dwellings. Single-unit, two-unit, and townhouse dwellings must provide required off-street parking spaces in an attached or detached garage.
6. Commercial Vehicles in Residential Districts. The following vehicles must not be parked in a residential zoning district unless the vehicle is parked in an enclosed garage, or is in use for deliveries, repairs, construction, maintenance, loading, or unloading: taxicabs, limousines, buses, tow trucks, semi-truck trailers, box trucks, construction vehicles, trailers for landscaping equipment, agricultural vehicles, antique vehicles, and other similar commercial vehicles.

B. Computation. Off-street parking spaces are determined using the following standards.

1. Units of Measurement.
 - a. Gross Floor Area. Unless otherwise stated, parking standards for non-residential uses must be calculated on the basis of gross floor area (GFA) in square feet (sf).
 - b. Occupancy- or Capacity-Based Requirements. Parking spaces required per employee, student, or occupant must be calculated based on the maximum number of employees on the largest shift, maximum enrollment of students, or maximum fire-rated capacity of the building, whichever measurement is applicable.
2. Fractions of Parking Spaces. When computation of parking spaces results in a fraction, any fraction of less than one-half must be disregarded, and any fraction of one-half or more must be counted as one parking space.
3. Multiple Uses on a Lot. When there are multiple uses on a lot, the number of parking spaces required must be the sum of the parking requirements for each individual use.
4. Use of Off-Street Loading Area. Area allocated to any off-street loading spaces must not be used to satisfy parking space requirements.

C. Parking Standards⁹. [Table 10.02.1 Off-Street Parking Standards](#) establishes the minimum and maximum vehicular parking requirements for the listed uses. [Table 10.02.1](#) also establishes the minimum short-term and long-term bicycle parking requirements for the listed uses.

1. MD District. In the MD District, properties shall not be required to provide off-street parking spaces with the exception that residential uses must provide a minimum of 0.5 parking spaces per dwelling unit or per bedroom.
2. Special Uses. In all zoning districts, approved special uses may be subject to minimum parking requirements established through the special use permit approval process (see [Section 4.03 \(Special Use Permit\)](#)).
3. Use Not Specified. Any use not specified in [Table 10.02.1 Off-Street Parking Standards](#) must adhere to the requirements provided for the most similar use as determined by the Zoning Officer.

⁹ Amended per Ordinance 1929.

Table 10.02.1 Off-Street Parking Standards¹⁰

Uses	Vehicle Parking Requirement		Bicycle Parking Requirement	
	Minimum Parking	Maximum Parking	Short-Term	Long-Term
Residential				
Community Residence	0.5 per bed	1 per bed	None	None
Dwelling Above the Ground Floor	1 per dwelling unit	1.5 per dwelling unit	None	None
Live/Work Dwelling	1 per dwelling unit	2 per dwelling unit	None	None
Mobile Home Dwelling	2 per dwelling unit	3 per dwelling unit	None	None
Multiple-Unit Dwelling	2 per dwelling unit, 0.75 of which enclosed	3 per dwelling unit, 2 of which enclosed	1 per 20 dwelling units	1 per dwelling unit
Residential Care Facility	1 per dwelling unit or bed, whichever is applicable	1.5 per dwelling unit or bed, whichever is applicable	1 per 25 dwelling units or beds, whichever is applicable	1 per 10 dwelling units or beds, whichever is applicable
Single-Unit Dwelling	4 per dwelling unit, 2 of which enclosed	4 enclosed per dwelling unit	None	None
Townhouse Dwelling	3 per dwelling unit, 1 of which enclosed	2 enclosed per dwelling unit	None	None
Two-Unit Dwelling	3 per dwelling unit, 2 of which enclosed	2 enclosed per dwelling unit	None	None
Civic and Institutional				
Cemetery	None	3 per 1,000 sf of GFA of office and/or preparation area	None	None
College or University	2 per classroom + 1 per 1,000 sf of office space + 1 per 20 students	2 per classroom + 3 per 1,000 sf of office space + 1 per 5 students	10 per classroom	1 per classroom
Community Garden	None	None	None	None
Cultural Facility	1 per 1,000 sf of GFA	1 per 1,000 sf of GFA	1 per 3,000 sf of GFA	1 per 15,000 sf of GFA
Elementary, Middle, or High School	1 per classroom + 1 per 10 students	2 per classroom + 3 per 1,000 sf of office space + 1 per 20 students	4 per classroom	1 per classroom
Government Facility	None	1 per 1,000 sf of GFA	1 per 3,000 sf of GFA	1 per 15,000 sf of GFA
Hospital	2 per bed	4 per bed	1 per 30,000 sf of GFA	1 per 15,000 sf of GFA
Park	None	None	None	None

¹⁰ Amended per Ordinance 1929.

Uses	Vehicle Parking Requirement		Bicycle Parking Requirement	
	Minimum Parking	Maximum Parking	Short-Term	Long-Term
Place of Worship	5 per 1,000 sf of GFA of largest assembly area	10 per 1,000 sf of GFA of largest assembly area	1 per 10,000 sf of GFA of largest assembly area	5% of maximum capacity of largest assembly area
Vocational School	1 per classroom + 1 per 10 students	2 per classroom + 3 per 1,000 sf of office space + 1 per 20 students	4 per classroom	1 per classroom
Commercial				
Adult Use	2 per 1,000 sf of GFA	4 per 1,000 sf of GFA	1 per 3,000 sf of GFA.	None
Animal Boarding, Hospital or Shelter	1 per 1,000 sf of GFA of indoor area	3 per 1,000 sf of GFA of indoor area	1 per 12,000 sf of GFA of indoor area	None
Banquet Hall	5 per 1,000 sf of GFA	12 per 1,000 sf of GFA	1 per 5,000 sf of GFA	None
Bar/Tavern	3 per 1,000 sf of GFA	6 per 1,000 sf of GFA	1 per 1,000 sf of GFA	None
Body Art Establishment	2 per 1,000 sf of GFA	4 per 1,000 sf of GFA	1 per 1,000 sf of GFA	None
Cannabis Craft Grower	1 per 1,000 sf of GFA	6 per 1,000 sf of GFA	1 per 3,000 sf of GFA.	None
Cannabis Dispensary	4 per 1,000 sf of GFA	6 per 1,000 sf of GFA	1 per 3,000 sf of GFA.	None
Car Wash	None	3 per bay	1 per 12,000 sf of GFA	None
Currency Exchange	None	3 per 1,000 sf of GFA	1 per 12,000 sf of GFA	None
Day Care Center	1 per 1,000 sf of GFA	2 per 1,000 sf of GFA	0.25 per classroom	1 per classroom
Day Care Home	None	None	None	None
Drive-Through Facility	None	None	None	None
Driving Range	0.5 per tee box	1 per tee box	1 per 10,000 sf of GFA	None
Financial Institution	1 per 1,000 sf of GFA	3 per 1,000 sf of GFA	1 per 1,000 sf of GFA	1 per 10,000 sf of GFA
Funeral Home/Crematory	10 per chapel or parlor	20 per chapel or parlor	2 per chapel or parlor	None
Garden Center	3 per 1,000 sf of GFA of indoor and outdoor areas	3 per 1,000 sf of GFA of indoor and outdoor areas	1 per 3,000 sf of GFA of indoor and outdoor areas + 1 per each additional 10,000 sf of GFA over 60,000 sf of GFA	1 per 10,000 sf of GFA of indoor and outdoor areas
Gas Station	4 per 1,000 sf of GFA of any retail use	4 per 1,000 sf of GFA of any retail use	1 per 3,000 sf of GFA of any retail use	None
Golf Course	2 per tee box	3 per tee box	2 per 9 holes	1 per 9 holes
Hotel/Motel	2 per 1,000 sf of GFA	4 per 1,000 sf of GFA	1 per 30,000 sf of GFA	1 per 15,000 sf of GFA
Indoor Entertainment	2 per 1,000 sf of GFA	5 per 1,000 sf of GFA	1 per 10,000 sf of GFA	1 per 15,000 sf of GFA
Indoor Recreation	2 per 1,000 sf of GFA	5 per 1,000 sf of GFA	1 per 10,000 sf of GFA	1 per 15,000 sf of GFA
Laundromat	2 per 1,000 sf of GFA	5 per 1,000 sf of GFA	1 per 10,000 sf of GFA	1 per 15,000 sf of GFA
Microbrewery or Microdistillery	4 per 1,000 sf of GFA	8 per 1,000 sf of GFA	1 per 10,000 sf of GFA	1 per 20,000 sf of GFA

Uses	Vehicle Parking Requirement		Bicycle Parking Requirement	
	Minimum Parking	Maximum Parking	Short-Term	Long-Term
Motor Vehicle Operations Facility	None	1 per 1,000 sf of GFA	1 per 12,000 sf of GFA	None
Motor Vehicle Rental	None	4 per 1,000 sf of GFA	1 per 12,000 sf of GFA	None
Motor Vehicle Repair and/or Service	2 per 1,000 sf of GFA	4 per 1,000 sf of GFA	1 per 12,000 sf of GFA	None
Motor Vehicle Repair and/or Service Body Shop	2 per 1,000 sf of GFA	4 per 1,000 sf of GFA	1 per 12,000 sf of GFA	None
Motor Vehicle Sales	None	4 per 1,000 sf of GFA	1 per 12,000 sf of GFA	None
Multi-Tenant Commercial Center	2 per 1,000 sf of GFA	4 per 1,000 sf of GFA	1 per 3,000 sf of GFA + 1 per each additional 10,000 sf of GFA over 60,000 sf of GFA	1 per 10,000 sf of GFA
Outdoor Entertainment or Recreation	3 per 1,000 sf of lot area	8 per 1,000 sf of lot area	10% of maximum capacity	None
Pawn Shop	2 per 1,000 sf of GFA	4 per 1,000 sf of GFA	1 per 3,000 sf of GFA	None
Payday/Title Loan Establishment	1 per 1,000 sf of GFA	3 per 1,000 sf of GFA	1 per 12,000 sf of GFA	None
Personal Services Establishment	1 per 1,000 sf of GFA	3 per 1,000 sf of GFA	1 per 1,000 sf of GFA	1 per 10,000 sf of GFA
Professional Office	1 per 1,000 sf of GFA	3 per 1,000 sf of GFA	1 per 12,000 sf of GFA	1 per 6,000 sf of GFA
Research/Development Facility	1 per 1,000 sf of GFA	2 per 1,000 sf of GFA	4 spaces for any use larger than 60,000 sf of GFA	1 per 20,000 sf of GFA
Restaurant	5 per 1,000 sf of GFA	12 per 1,000 sf of GFA	1 per 1,000 sf of GFA	1 per 10,000 sf of GFA
Retail Goods Establishment	2 per 1,000 sf of GFA	4 per 1,000 sf of GFA	1 per 3,000 sf of GFA + 1 per each additional 10,000 sf of GFA over 60,000 sf of GFA	1 per 15,000 sf of GFA
Self-Service Storage	None	1 per 1,000 sf of GFA	4 spaces for any use larger than 60,000 sf of GFA	None
Manufacturing				
Cannabis Cultivation Center	1 per 1,000 sf of GFA	6 per 1,000 sf of GFA	4 spaces for any use larger than 60,000 sf of GFA	1 per 20,000 sf of GFA
Cannabis Infuser	1 per 1,000 sf of GFA	6 per 1,000 sf of GFA	4 spaces for any use larger than 60,000 sf of GFA	1 per 20,000 sf of GFA
Cannabis Transporter	0.5 per 1,000 sf of GFA	6 per 1,000 sf of GFA	4 spaces for any use larger than 60,000 sf of GFA	2 spaces for any use larger than 60,000 sf of GFA

Uses	Vehicle Parking Requirement		Bicycle Parking Requirement	
	Minimum Parking	Maximum Parking	Short-Term	Long-Term
Heavy or Light Manufacturing	0.5 per 1,000 sf of GFA	6 per 1,000 sf of GFA	4 spaces for any use larger than 60,000 sf of GFA	2 spaces for any use larger than 60,000 sf of GFA
Machinery and Equipment Sales and Rental	1 per 1,000 sf of GFA	6 per 1,000 sf of GFA	4 spaces for any use larger than 60,000 sf of GFA	2 spaces for any use larger than 60,000 sf of GFA
Warehousing, Storage, or Distribution Facility	0.5 per 1,000 sf of GFA	6 per 1,000 sf of GFA	4 spaces for any use larger than 60,000 sf of GFA	2 spaces for any use larger than 60,000 sf of GFA
Other Uses				
Agricultural Use	None	None	None	None
Club, Lodge, or Hall	None	5 per 1,000 sf of GFA	1 per 12,000 sf of GFA	1 per 20,000 sf of GFA
Small Cell Wireless Telecommunication Antenna	None	None	None	None
Train Station	None	None	20 spaces	20 spaces
Utility	None	1 per 4 employees	1 space per 15,000 sf of GFA	None
Utility-Scale Solar or Wind Energy System	None	1 per 4 employees	None	None
Wireless Telecommunication Facility or Tower	None	None	None	None

10.03 Bicycle Parking

- A. Applicability. Minimum bicycle parking requirements apply to the use categories in [Table 10.02.1 Off-Street Parking Standards](#), provided that those use categories meet the development thresholds listed in [Section 10.01.B \(Applicability\)](#).
- B. Minimum Requirement. Where bicycle parking is required, a minimum of two spaces must be provided.
- C. Bicycle Parking Design. Bicycle parking spaces must be designed in accordance with the following requirements:
 - 1. Dimensions. Each bicycle parking space must have a minimum width of two feet, minimum length of six feet, and minimum vertical clearance of seven feet, see [Figure 10.03.1 Bicycle Parking Design](#).
 - 2. Safe Access. Bicycle parking spaces must be protected from motor vehicle traffic and located to permit safe access to and from the use served. A sidewalk, shared path, or other means of access, with a minimum width of five feet, must be provided adjacent to bicycle parking facilities to ensure adequate maneuvering space.
 - 3. Racks and Structures. Secure racks and supporting structures must be provided for each bicycle parking space, and must be designed to accommodate both chain and U-shaped locks. Bicycle parking spaces must permit the bicycle frame and one wheel to be locked to the rack and supporting structure. A locked bicycle must be supported in a stable position without damage to the wheels, frame, or components.
 - 4. Visibility and Maintenance. Areas used for bicycle parking must be designed and maintained to be well-lit and reasonably free from standing water, mud, and dust.
 - 5. Signage. If bicycle parking spaces for non-residential uses are not visible from the street, signs must be posted to indicate the location of such parking.

Figure 10.03.1 Bicycle Parking Design

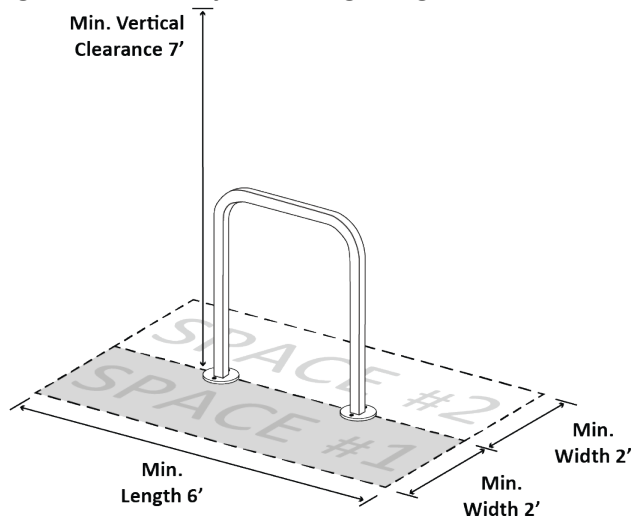

E. Short-Term Bicycle Parking. The following standards apply to required short-term bicycle parking spaces, as established in [Table 10.02.1 Off-Street Parking Standards](#).

1. Location. Short-term bicycle parking must be located in a highly visible, publicly-accessible location within 50 feet of the principal entrance to a building containing the use it serves. For buildings or uses requiring more than eight short-term bicycle parking spaces, parking spaces in excess of these eight spaces may be located more than 50 feet from the principal building entrance.
2. Spaces Within the Right-Of-Way. With the permission of the Village Engineer, the property owner may install the required short-term bicycle parking spaces within the public right-of-way.
3. Credit for Existing Public Parking Facilities. With the permission of the Zoning Officer, the property owner may receive credit for existing public bicycle parking spaces located in the right-of-way, or on Village property, to comply with the required short-term bicycle parking.
4. Fee-In-Lieu. A fee-in-lieu of providing short-term bicycle parking spaces may be permitted with written approval of the Zoning Officer in instances where the Zoning Officer determines that providing short-term bicycle parking on-site is not practical. The fee required will be based upon a uniform fee per short-term bicycle parking space established as a one-time fee by the Village Board. Such payment must be placed into a fund to be used by the Village for the acquisition, construction, and maintenance of short-term bicycle parking located in the public right-of-way, or on Village owned property within the same zoning district as the subject use or within adjacent zoning districts of reasonable proximity to serve the subject use. The lot granted the reduction in the number of required short-term bicycle parking spaces must be credited permanently by ordinance or resolution identifying the number of spaces for which payment was received by the Village.

F. Long-Term Bicycle Parking. The following standards apply to required long-term bicycle parking spaces, as established in [Table 10.02.1 Off-Street Parking Standards](#).

1. Location. Long-term bicycle parking must be located within an enclosed, limited-access area designed to protect bicycles from inclement weather, unauthorized use, and theft, and must adhere to the following:
 - a. Long-term bicycle parking must be provided within the building containing the use that it is intended to serve, or within a structure that has a principal entrance 200 feet or less from the principal entrance to such building.
 - b. Long-term bicycle parking serving multiple uses or buildings may be combined into a single area, enclosure, or facility.
 - c. Where long-term bicycle parking is located adjacent to vehicular parking or loading facilities, a physical barrier must be provided to prevent damage to bicycles by motor vehicles.

2. Facilities. Long-term bicycle parking spaces may be provided within the following types of facilities:
 - a. Enclosed spaces within a building, such as bicycle rooms or garages.
 - b. Bicycle sheds.
 - c. Bicycle lockers.
 - d. Other enclosed or covered spaces as approved by the Zoning Officer.

10.04 Parking Design Standards

- A. Dimensions. All off-street parking aisles and spaces must be designed in compliance with the requirements established in [Table 10.04.1 Off-Street Parking Dimensions](#) and [Figure 10.04.1 Parking Lot Layout](#).
 1. Vertical Clearance. Each parking space must have a minimum vertical clearance of seven, feet-six inches.
 2. Compact Spaces. Up to 25 percent of the total off-street parking facilities may be met with compact parking spaces. Compact spaces must be located in contiguous areas, and must not be mixed with spaces designed for full-size cars.
 3. Semi-Truck Trailers. The dimensions for semi-truck trailers are 12 feet in width, 60 feet in length, and 14 feet in vertical clearance.

Table 10.04.1. Off-Street Parking Dimensions

Angle	Car Type	Space Width (W)	Space Depth (D)	Aisle Width: One-Way (O)	Aisle Width: Two-Way (T)
0° (Parallel)	Full Size	9 ft	20 ft	12 ft	24 ft
45°	Full Size	9 ft	18 ft	12 ft	24 ft
60°	Full Size	9 ft	18 ft	18 ft	24 ft
90° (Head-In)	Full Size	9 ft	18 ft	24 ft	24 ft

Figure 10.04.1. Parking Lot Layout

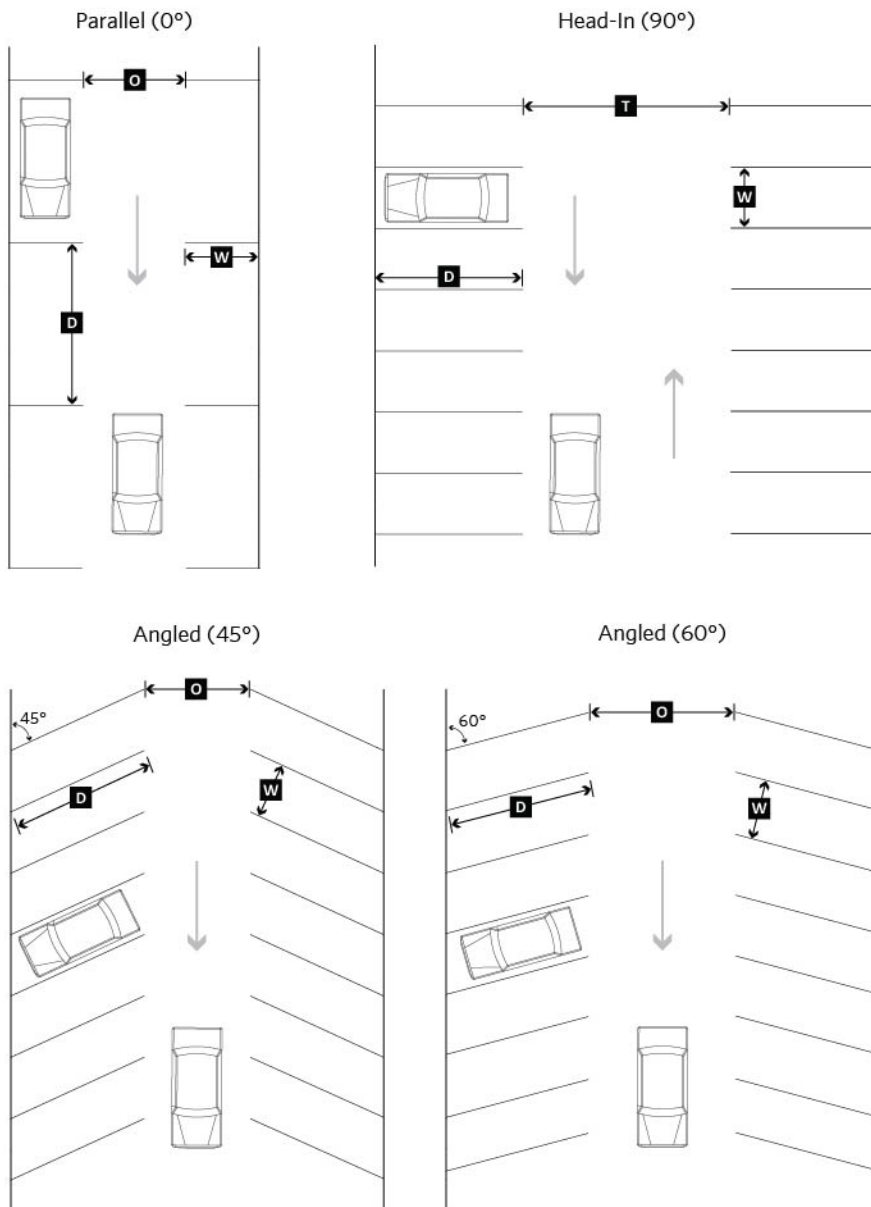

B. Materials. All off-street parking lots, loading areas, drive-through facilities, and driveways must be constructed using a hard surface, all-weather, dustless material.

1. Pervious Paving Materials. Pervious paving materials for parking facilities are encouraged. In all districts, the use of pervious paving materials is subject to the prior written approval of the Zoning Officer or their designee.
2. Recycled Materials. Recycled materials are encouraged and may be used for parking facilities subject to the prior written approval of the Zoning Officer or their designee.

C. Access.

1. **Parking Lots.** Parking lots must be designed with adequate means of vehicular access from a driveway, street, or alley in a manner that minimizes interference with traffic movement. Parking facilities must be designed to allow the driver to proceed forward into traffic from an access point, rather than backing out. Parking facilities that serve single-unit, two-unit, and townhouse dwellings are exempt from this requirement.
2. **Parking Spaces.** Each parking space within a parking lot must open directly onto an aisle or driveway of sufficient width to provide adequate means of vehicular access to the parking space.
3. **Cross-Access Drives.** Mixed-use and non-residential uses are encouraged to provide a cross-access drive to allow circulation between adjacent sites. Property owners who establish cross-access drives must record an easement allowing cross-access, receive written approval from the Zoning Officer, and record a joint maintenance agreement that defines maintenance responsibilities.

D. **Striping.** Off-street parking lots must delineate parking spaces with paint or another permanent, durable material that is clearly visible.

E. **Wheel Stops, Bumper Stops, and Curbing.** Wheel stops, bumper stops, and/or curbing must be permanently and securely installed along the perimeter of parking lots to prevent vehicles from encroaching on sidewalks, landscape areas, fencing, walls, or buildings. The Zoning Officer may waive this requirement upon determining that appropriate stormwater infrastructure is present.

F. **Drainage.** Off-street parking lots must be graded for proper drainage so that water will not flow into adjacent properties, as approved by the Village Engineer. On-site retention and filtration of stormwater must be provided where practical.

G. **Landscape Requirements.** Parking facilities must meet the applicable landscape requirements of [Section 11 \(Landscape Standards\)](#).

H. **Outdoor Lighting Requirements.** Parking facilities must meet the applicable outdoor lighting requirements of [Section 11.09 \(Outdoor Lighting\)](#).

I. **Sign Requirements.** Parking facilities must meet the applicable sign requirements of [Section 12 \(Signs\)](#).

- J. **Snow Storage.** Snow storage areas must be provided on or adjacent to all off-street parking facilities.
1. **Obstructions.** Snow must be stored in a manner that does not restrict access or circulation for pedestrians or vehicles.
 2. **Storage in Landscape Areas.** Landscape areas must not be used for snow storage unless designed for that purpose with non-compacted soils and plantings selected for salt-tolerance and durability.
 3. **Storage in Stormwater Management Facilities.** Snow should not be stored on top of storm drain catch basins or within stormwater management facilities.

4. Off-Site Snow Storage. If snow storage cannot be accommodated on-site, the applicant must make arrangements for off-site snow storage with approval from the Zoning Officer.

10.05 Pedestrian Circulation Systems

- A. Applicability. Off-street parking areas require pedestrian circulation systems to ensure the safety of pedestrian, bicyclists, and motorists in accordance with the applicability standards of [Section 10.01.B.1-3](#). Refer to [Figure 10.05.1 On-Site Pedestrian Circulation](#).
- B. Required Connections. The pedestrian circulation system must connect all buildings on the site to one another and provide walkway connections to vehicle parking facilities, bicycle parking facilities, adjacent public rights-of-way, and to adjacent properties along a shared street frontage. The Zoning Officer may waive this requirement upon determining that such connection would not be feasible or if it would create a safety hazard.

Figure 10.05.1 On-Site Pedestrian Circulation

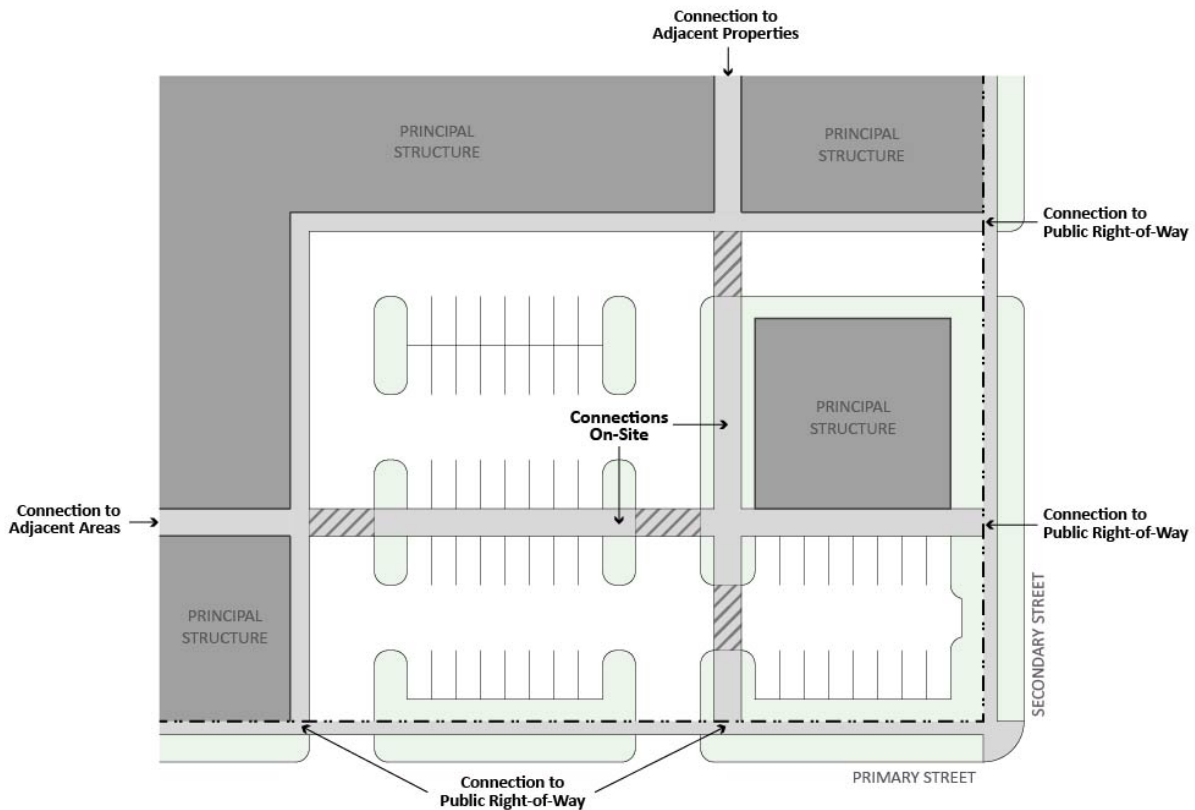

- C. Design Standards for On-Site Pedestrian Circulation Systems. On-site pedestrian circulation systems must be designed in accordance with the following requirements:

1. Width. The pedestrian circulation system must be paved with a minimum width of five feet.

2. Clear Markings. Where the pedestrian circulation system crosses driveways, drive aisles, or loading areas, it must be clearly marked by a change in grade, a change in materials, special pavers, stamped asphalt or concrete. Painted striping does not meet this requirement.
3. Raised Surface. Where the pedestrian circulation system is parallel to an adjacent driveway or drive aisle, it must be raised at least four inches above the surface of the auto travel lane surface and separated by a raised curb. The pedestrian circulation system may also include landscaping, decorative bollards, or other architectural features.
4. Frontage Sidewalk. A sidewalk with a minimum width of seven feet is required along the full length of any building frontage containing a primary entrance that is directly adjacent to a parking row, driveway, or drive aisle. Refer to [Figure 10.05.2 Frontage Sidewalk](#).
5. Integrated Design. The design of pedestrian circulation systems must be integrated with parking lot landscaping in accordance with [Section 11.05 \(Parking Lot Landscaping\)](#), where appropriate.

Figure 10.05.2 Frontage Sidewalk

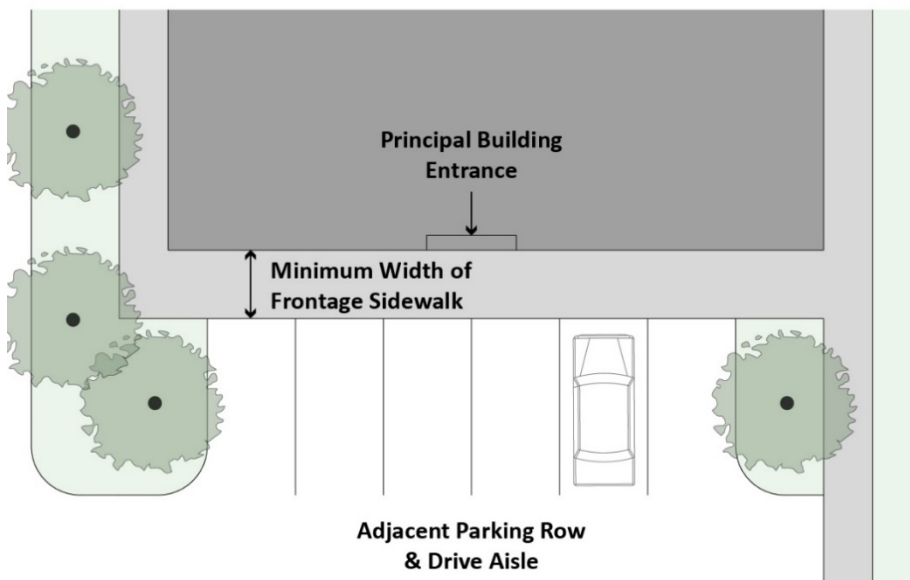

10.06 Driveways

Driveways providing access to a lot from a right-of-way, alley, or other vehicular access point must adhere to the following.

- A. Location. Driveways are permitted to encroach into the required front yard, corner side yard, interior side yard and/or rear yard, but must be at least one foot from the interior side lot line, except when the driveway provides shared access for two adjacent properties. Driveways must be essentially perpendicular to the right-of-way being accessed.

- B. Quantity. One driveway per street frontage is allowed, provided that the minimum frontage requirements established in [Section 8 \(Zoning District Regulations\)](#) are met. Driveways must be located at least 60 feet from a signalized intersection, and 30 feet from all other intersections, measured from edge of pavement. Lots with at least 150 linear feet of frontage per block face may incorporate one additional driveway along that frontage. On properties for which more than one driveway is permitted, the distance between the driveways must be a minimum of 50 feet.
- C. Driveway Width. Driveways must be constructed in compliance with [Table 10.06.1 Maximum Driveway Width](#). Driveway width must be measured at the lot line.

Table 10.06.1 Maximum Driveway Width

Uses*	One-Way Driveway	Two-Way Driveway
Single-Unit	25ft	N/A
Two-Unit Dwellings with Two-Car Garage Door	20 ft	N/A
Two-Unit Dwellings with One-Car Garage Door	12 ft	N/A
Townhouse Dwelling Units	20 ft	N/A
Multiple-Unit Dwellings	12 ft	26 ft
Commercial, Civic, and Institutional	12 ft	26 ft
Industrial	15 ft	35 ft
*Note: See Table 9.02.1 Principal Uses and Structures for more information on uses.		

- D. Visibility. No building, structure, sign, or landscape element may obstruct the area between 2.5 feet and eight feet in height within the sight triangle area on each side of any driveway. Beginning at the intersection of the driveway with the lot line, the sight triangle is formed by measuring 10 feet along the lot line in the opposite direction of the driveway and 10 feet along the driveway in the opposite direction of the lot line, then connecting the endpoints of the lines across the subject lot (refer to [Figure 10.06.1 Visibility at Driveways](#)).

Figure 10.06.1 Visibility at Driveways

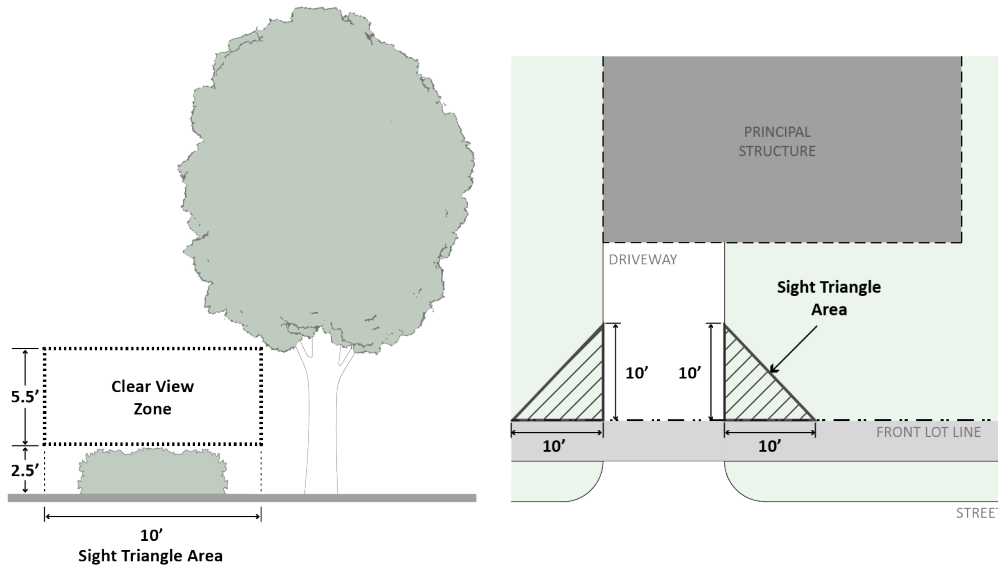

E. Turning Radii.

1. Multiple-Unit Dwellings and Commercial Uses. Entrances to multiple-unit dwellings and commercial uses must have a minimum turning radii of 15 feet and a maximum turning radii of 35 feet.
2. Industrial Uses. Entrances to industrial uses must have a minimum turning radii of 25 feet and a maximum turning radii of 60 feet.

F. Intersection of Sidewalk and Driveway.

1. Sidewalk. In locations where a sidewalk is crossed by a driveway, the sidewalk must be constructed of a permanent, concrete surface with a minimum width of five feet.
2. Driveway Aprons. Driveway aprons must not exceed the width of a driveway by more three feet on each side of the driveway. Driveway aprons must be constructed of asphalt or concrete material as approved by the Village Engineer.
3. Slope. A sidewalk must remain level across the driveway with a running slope not to exceed 8.3 percent if there is a landing, or 5 percent if there are no landings. A landing is an area that is a minimum of five feet by five feet that has a cross slope of two percent or less at the top and bottom of the ramp. The cross slope must not exceed two percent, but a cross slope of 1.5 percent is recommended. Refer to [Figure 10.06.2 Sidewalk and Driveway Intersection Designs.](#)

Figure 10.06.2 Sidewalk and Driveway Intersection Designs

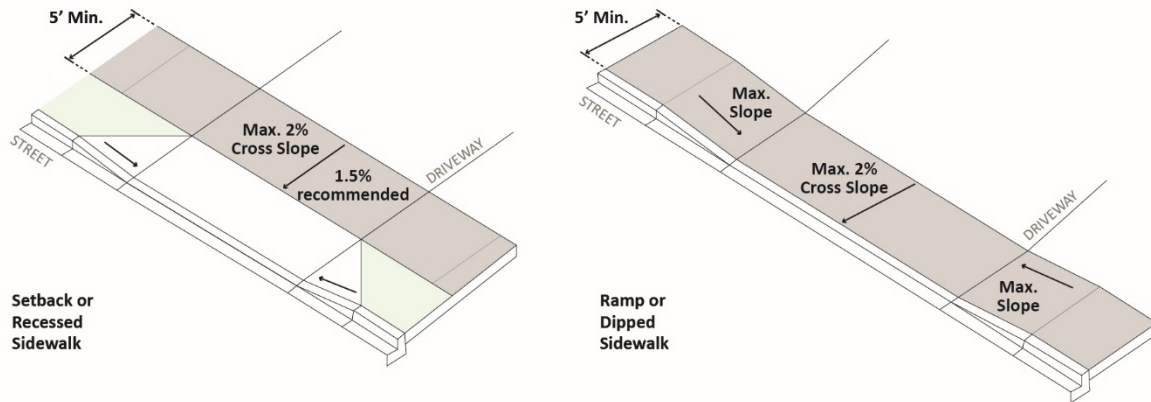

G. Residential Driveways. The following standards apply to driveways for single-unit, two-unit, and townhouse dwellings only.

1. Driveway Parking. Vehicles are permitted to park on driveways provided that the vehicles do not encroach into rights-of-way.
2. Alley Orientation. Where an alley exists adjacent to the side or rear lot line, all motor vehicle access to a garage must occur through the alley in accordance with [Section 9.03.B.16 \(Garage\)](#).
3. Driveway Parking Pad. A parking pad the width of the garage served by the driveway is permitted to extend up to 20 feet in depth from the garage doors before tapering back to the required driveway width, see [Figure 10.06.3 Driveway Parking Pad Width](#).

Figure 10.06.3 Driveway Parking Pad Width

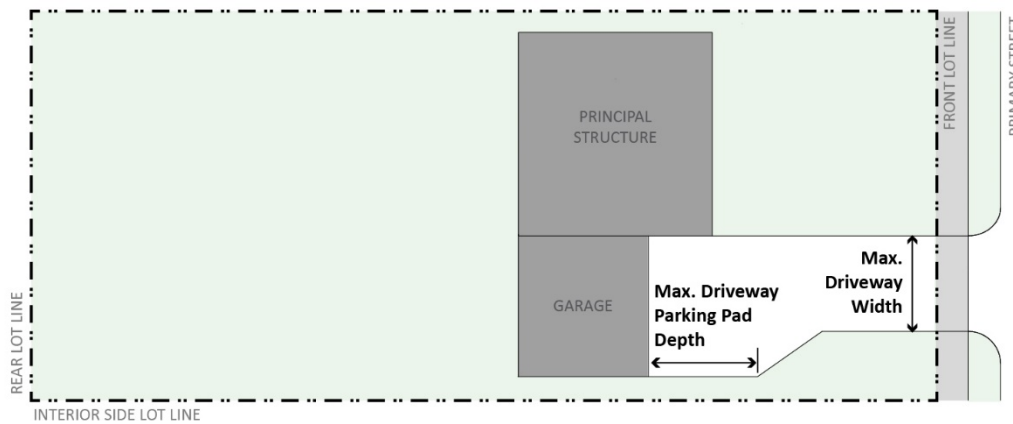

10.07 Vehicular Stacking Requirements

- A. Space Requirements. Restaurant and coffee shop uses must provide a minimum of six stacking spaces per drive-through lane. Car wash uses must provide a minimum of four stacking spaces per drive-through lane. All other uses must provide a minimum of two stacking spaces per drive-through lane.
- B. Dimensions. All stacking spaces must have a minimum width of nine feet, as measured from the edge of the drive-through lane to the outermost edge of the last point of service, such as a drive-through window. Stacking spaces must have a minimum length of 18 feet.
- C. Location. Stacking spaces must be located behind the vehicle parked at the last point of service, such as a drive-through window, and placed in a line within the drive-through lane. Stacking spaces must be located so that they do not obstruct access to the site or to parking and loading spaces. Refer to [Figure 10.07.1 Stacking Spaces](#).
- D. Bailout Lane. Drive through lanes must include a bailout lane, which must run parallel to the drive through lane, have a minimum width of 10 feet, and provide unobstructed exit capability to all vehicles that have entered the drive-through lane. A drive aisle may serve as a bailout lane provided that it meets the requirements of this section.

Figure 10.07.1 Stacking Spaces

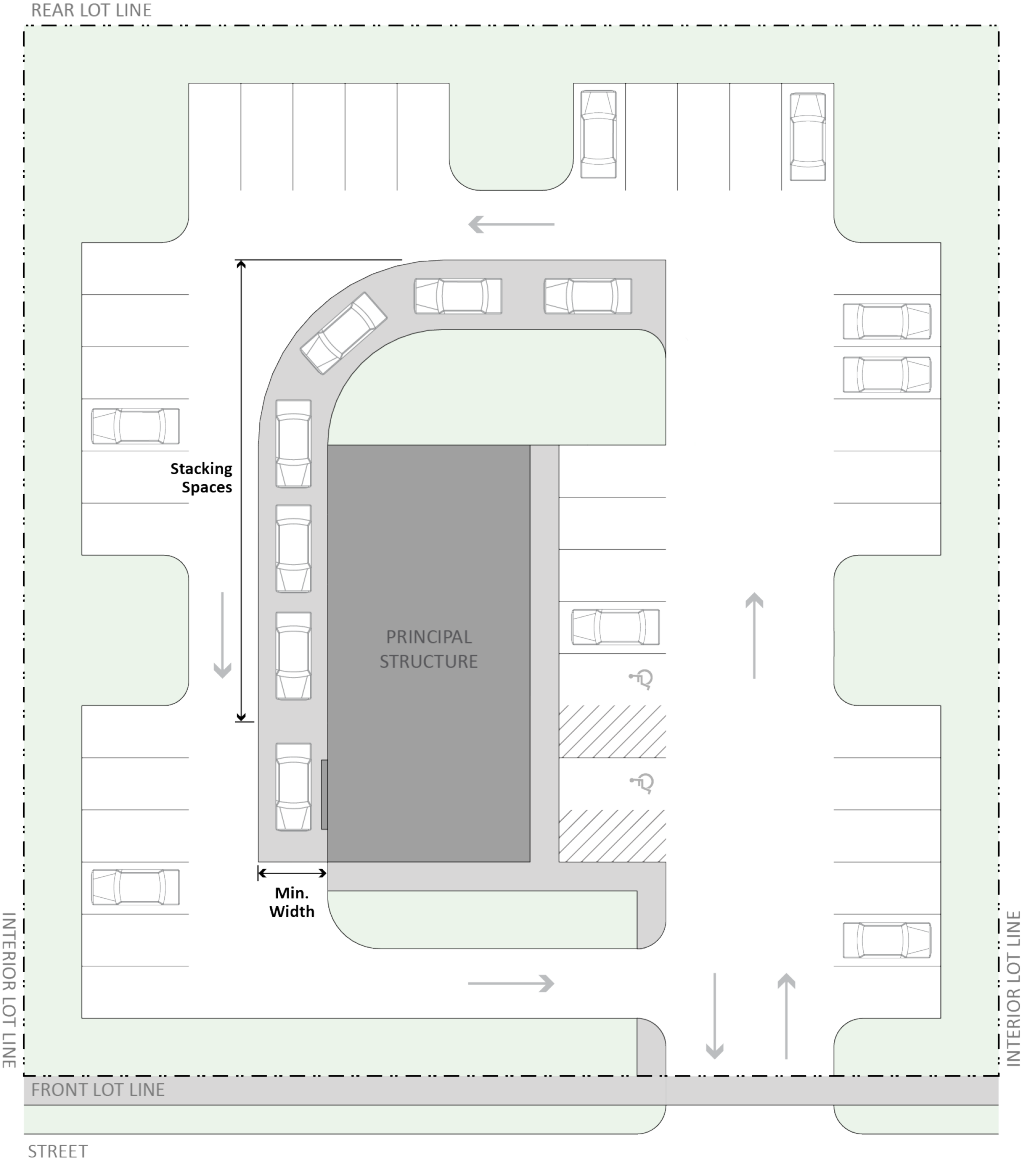

10.08 Recreational Vehicle Parking

- A. Number. No more than one recreational vehicle may be parked outdoors on a lot in any zoning district. Recreational vehicles stored in an enclosed permanent structure are exempt from this standard. A recreational vehicle and the trailer used to convey it must be considered one recreational vehicle. Non-motorized personal watercraft, such as canoes and kayaks, are not included as part of the total number of recreational vehicles allowed on a lot.
- B. Use. Recreational vehicles must not be used for living, sleeping or housekeeping purposes while located within Village boundaries. Recreational vehicles must not be connected to sewer, water, or other utilities for any period of time, except for temporary service connections for basic maintenance.
- C. Principal and Accessory Structures. Recreational vehicles are not permitted on a lot without a principal structure. Recreational vehicles must not be used as accessory structures, but may be kept within an enclosed accessory structure provided that the accessory structure is allowed in accordance with the requirements of [Section 9.03 \(Accessory Structures and Uses\)](#).
- D. Operability. Recreational vehicles must remain operable at all times. Recreational vehicles must not be permanently affixed to the ground in a manner that would prevent timely removal.
- E. Proprietorship. Recreational vehicles must be owned, leased, or rented by the occupant of the lot on which the recreational vehicles are parked.
- F. Location. Recreational vehicles must not be parked on any street within the Village. Recreational vehicle parking is allowed in the interior side yard and/or rear yard. Recreational vehicles in the interior side yard must be parked at least one foot from the interior side lot line, except when the driveway provides shared access for two adjacent properties. Recreational vehicles in the rear yard must be parked at least three feet from the rear lot line. A recreational vehicle may be parked in a driveway in any yard for a period of 48 hours for the purposes of loading and unloading.
- G. Parking Surface and Dimensions. Recreational vehicles must be parked on a hard surface, all-weather, dustless material in accordance with [Section 10.04.B \(Materials\)](#) that is equal or greater in length and width to the recreational vehicles being parked and/or stored.

10.09 Off-Street Loading Facility Requirements

- A. Applicability. This Ordinance does not specify minimum requirements for off-street loading. The maximum number of loading spaces required for any zoning lot is four spaces, but this standard does not apply to warehousing, storage, or distribution facility uses.
- B. Dimensions. Loading spaces must have a minimum width of 10 feet, minimum length of 25 feet, and minimum vertical clearance of 14 feet.
- C. Location. All loading spaces must be located on the same zoning lot as the use served, unless an alternate location has been approved by the Zoning Officer through the site plan review process (see [Section 4.02 \(Site Plan Review\)](#)).

1. Side or Rear Yard. Loading facilities must be located in the interior side and/or rear yard of the lot. A designated loading area may be located within a drive aisle with prior written approval from the Zoning Officer.
 2. Residential Districts. A loading space must not be closer than 50 feet from the lot line of a residential district, unless the space is screened in accordance with [Section 11.7.C \(Off-Street Loading Area Screening Requirements\)](#).
 3. Intersections. Loading spaces must be located at least 50 feet from a signalized intersection, and 25 feet from all other intersections, measured from edge of pavement.
- D. Access. Each required off-street loading space must have appropriate means of vehicular access from a driveway, street, or alley in a manner that minimizes interference with traffic movement. A loading space must not project into or block a street, sidewalk, alley, access drive, or parking area. Loading facilities must be designed to allow the driver to proceed forward into traffic from an access point, rather than backing out.

SECTION 11: LANDSCAPE STANDARDS

[11.01 General Provisions](#)

[11.02 Tree Preservation](#)

[11.03 Design, Installation, and Maintenance](#)

[11.04 Street Trees](#)

[11.05 Parking Lot Landscaping](#)

[11.06 Buffer Yards](#)

[11.07 Screening Requirements](#)

[11.08 Landscaped Setbacks](#)

[11.09 Outdoor Lighting](#)

11.01 General Provisions

- A. Purpose. The purpose of this Section is to establish landscape requirements that will enhance the Village's character and livability, improve water and air quality, mitigate the heat island effect, reduce the amount of stormwater conveyed to storm sewer systems, prevent erosion, expand and improve habitat for native plants and animals, and provide for transitions between zoning districts.
- B. Applicability. The requirements of this Section apply to the following:
1. New developments that require site plan review approval (see [Section 4.02 \(Site Plan Review\)](#)).
 2. Planned unit developments (see [Section 5 \(Planned Unit Developments\)](#)).
 3. The construction, expansion, or reconstruction of any parking lot of 10 spaces or more.
 4. The removal of existing trees from any lot, per the requirements of [Section 11.02 \(Tree Preservation\)](#).
- C. Occupancy Permit. The requirements of this Section must be met and landscape elements must be fully installed in good health and condition, as determined by the Zoning Officer, prior to the issuance of an occupancy permit.
1. Seasonal Conditions. If seasonal conditions preclude the completion of landscape installation, the applicant must provide the Village with a letter of credit, escrow, performance bond, or other surety, as approved by the Zoning Officer, equal to 110 percent of the remaining costs of installation and material as estimated by a qualified landscape architect or similar professional, in order to receive an occupancy permit.
 2. Permit Revocation. Failure to implement the approved landscape plan or maintain installed landscape elements is cause for revocation of the occupancy permit and/or the application of fines and penalties. All landscape elements are subject to periodic inspection for compliance with the approved landscape plan.

D. Landscape Plan. A landscape plan must be submitted to the Village as part of any site improvement that meets the criteria of [Section 11.01.B \(Applicability\)](#), and be approved by the Zoning Officer. The landscape plan will be evaluated and approved based on the standards included in this [Section 11 \(Landscape Standards\)](#).

1. Preparation of Landscape Plan. The landscape plan must be prepared and stamped by a licensed landscape architect registered in the State of Illinois, or another qualified professional, if the project meets the criteria of [Section 11.01.B \(Applicability\)](#).
2. Contents. The landscape plan must contain the following:
 - a. Location and dimensions of all existing and proposed structures, parking spaces, landscape islands, buffer yards, street lights, utilities, easements, and other site elements.
 - b. Location, quantity, size, spacing, and name, both botanical and common, of all existing plants, including trees and plants in the right-of-way. The landscape plan must indicate whether existing plants will be retained or removed, including information on how existing trees will be preserved and protected (see [Section 11.02 \(Tree Preservation\)](#)).
 - c. Location, quantity, size, spacing, and name, both botanical and common, of all proposed plants including the type of tree stock.
 - d. Planting details and best management practices for all plantings, including type, depth and quantity of soil.
 - e. A stormwater basin planting plan following the Village's [Naturalized Stormwater Management Facility Design, Planting and Management Plan Guidelines](#).
 - f. Existing and proposed grading of the site indicating contours at one-foot intervals.
 - g. Elevations of all fences and retaining walls proposed for the site.
 - h. Construction information, including the location of temporary roads, access points for construction equipment, staging areas, material storage areas, and other related information.
 - i. To ensure ongoing compliance with this Section, a landscape plan must include an operations and maintenance plan that includes detailed information on operations and maintenance procedures. The property owner is responsible for the maintenance of all elements of the landscape plan.

E. Credit for Existing Vegetation. The Zoning Officer may credit existing landscape elements toward the requirements of [Section 11.04 \(Street Trees\)](#), [Section 11.05 \(Parking Lot Landscaping\)](#), [Section 11.06 \(Buffer Yards\)](#), and/or [Section 11.07 \(Screening Requirements\)](#). The existing landscape elements must be acceptable species, adequately protected during the construction process, in good health, and must meet all applicable specifications of this Section.

11.02 Tree Preservation

A. Applicability. Existing trees six inches or larger may not be removed from lots within the Village, wholly or in part, without a tree preservation and removal plan approved by the Zoning Officer. This Section does not apply to the removal of trees located on lots for single-unit or two-unit dwellings, unless the tree(s) to be removed have a diameter of 30 inches or more, measured at breast height.

1. Procedure. The tree preservation and removal plan must specify the tree to be removed and must be approved by the Zoning Officer in writing. Such approval is not required if tree removal is performed by Village employees or contractors.

2. Criteria for Removal of Mature Trees. Every reasonable effort must be made to incorporate existing trees into the landscape plan for the proposed development. The Zoning Officer must determine that one of the following criteria apply prior to granting approval to remove a mature tree:
 - a. The tree is dead, dying, diseased, or a threat to public health or safety.
 - b. The tree interferes with the provision of public services or is a hazard to traffic.
 - c. The location of the tree prevents development or redevelopment that cannot be designed to protect the tree.
 - d. The tree is not on the Village of Montgomery Tree Species List for preferred species.
- B. Replacement Standards. Mature trees to be removed must be replaced in accordance with the following standards.
1. Location. Replacement trees must be planted on the zoning lot in question to the greatest extent possible. If the replacement trees cannot be planted on the zoning lot in question then the Zoning Officer will determine a suitable location for the replacement trees or a fee-in-lieu of the replacement trees in accordance with [Section 11.02.B.4 \(Fee-In-Lieu\)](#).
 2. Replacement Rate. The size of a mature tree is measured using its diameter at breast height (refer to [Figure 11.02.1 Tree Measurement](#)). The tree to be removed must be replaced within one year of the date of approval, or the applicant will be required to immediately pay the Village an amount equal to the full value of the tree to be removed.
 - a. Any tree designated for removal on an approved tree preservation and removal plan must be replaced at the rate specified in [Table 11.02.1 Tree Replacement Rates](#).
 - b. In the event that a tree designated for preservation is destroyed, damaged, or removed during the construction process, such tree must be replaced at the applicable rate specified in [Table 11.02.1 Tree Replacement Rates](#).
 3. Tree Valuation. The value of a tree will be determined by the Zoning Officer in accordance with the methods developed by the Council of Tree and Landscape Appraisers in the most recent *Guide for Plant Appraisal* regarding the quality and desirability of the tree.
 4. Fee-In-Lieu. A fee-in-lieu of providing replacement trees may be permitted with written approval of the Zoning Officer in instances where the Zoning Officer determines that the planting of such trees on-site is not practical. The fee required will be based upon a uniform fee per replacement tree established as a one-time fee by the Village Board. Such payment must be placed into a fund to be used by the Village for the acquisition, installation, and maintenance of replacement trees in the public right-of-way, or on Village owned property within the same zoning district as the subject use or within adjacent zoning districts of reasonable proximity to the subject use. The lot granted the fee-in-lieu of replacement trees must be credited permanently by ordinance or resolution identifying the number of trees for which payment was received by the Village.

Figure 11.02.1 Tree Measurement

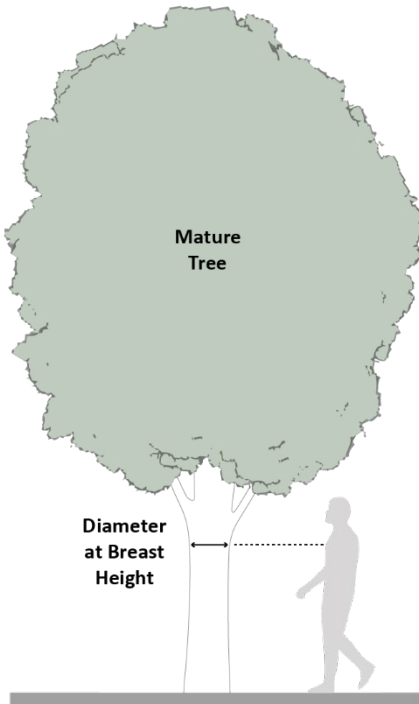

Table 11.02.1 Tree Replacement Rates

Caliper of Tree to be Removed	Number of Replacement Trees Required
6 to 12 inches	2
13 to 29 inches	4
30 inches or greater	6

11.03 Design, Installation, and Maintenance

A. Design and Installation.

1. National Standards. All landscape elements must be installed in accordance with the practices and procedures established by Illinois Landscape Contractors Association. Landscape elements must be healthy and hardy upon installation, and must be planted with appropriate space and soils to ensure sustained growth.
2. Soil Requirements. A minimum soil depth of 36 inches and minimum planting bed width of six feet is required for all tree planting areas. Refer to [Figure 11.03.1 Minimum Soil Depth](#) and [Figure 11.03.2 Minimum Planting Bed Width](#). In order to accommodate subsurface root expansion, a minimum volume of 1,000 cubic feet of structural soil is required per large shade tree or evergreen tree, and a minimum volume of 750 cubic feet of structural soil is required per medium shade tree. Whenever possible, tree plantings should be located to connect subsurface root spaces.

Figure 11.03.1 Minimum Soil Depth

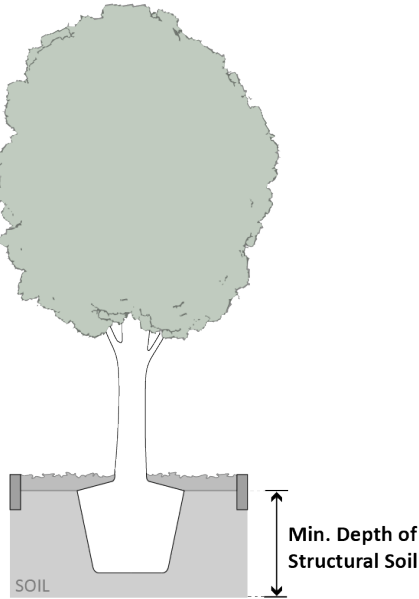
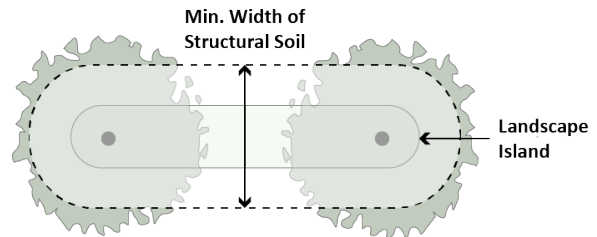

Figure 11.03.2 Minimum Planting Bed Width



3. Plant Size Requirements. Landscape elements must be installed in accordance with [Table 11.03.1 Required Landscape Size at Installation](#), unless otherwise noted in this Ordinance.

Table 11.03.1 Required Landscape Size at Installation

Type	Minimum Size	Maximum Size
Shrubs	18 in height	36 in height
Ornamental Tree	1.5 in caliper	2.5 in caliper
Deciduous Shade Tree, Single Trunk	1.5 in caliper	2.5 in caliper
Deciduous Shade Tree, Multiple Trunks	6 ft height	10 ft height
Evergreen Tree	6 ft height	10 ft height

4. Tree Species Permitted and Species Diversity. Tree and plant species that are native or naturalized to northeastern Illinois, and drought- and salt-tolerant, are required, except for single-unit and two-unit dwellings. Refer to the most recent Village of Montgomery Tree Species List for preferred species and [Table 11.03.2 Species Diversity Requirements](#) for specifications.

Table 11.03.2 Species Diversity Requirements

Lot Size	Minimum Percent Drought- and Salt-Tolerant Species	Tree Species Diversity Requirement*	
Lot under 0.5 acres	50%	None	
Lot between 0.5 and 5 acres	60%	Species	20%
		Genus	40%
		Family	60%
Lot over 5 acres	75%	Species	5%
		Genus	10%
		Family	15%

* Trees from the genus *Quercus* (oaks) are exempt from these restrictions.

5. **Runoff Infiltration.** All required parking lot landscape areas must be designed to accept and facilitate stormwater runoff infiltration through curb design, adequate soil depth, appropriate plant selection, and site grading to convey stormwater to the landscaped areas in accordance with the Stormwater Ordinance. Landscaped areas must include depressed planters with bioretention and infiltration areas to assist in water quality protection and facilitate groundwater recharge.
6. **Curb Design.** Landscape areas must be protected with concrete curbing and have a minimum height of six inches as measured from the parking lot surface. Curbing must contain inlets to accept drainage, unless it is determined by the Zoning Officer that inlets would result in greater runoff volume inflow than could be supported by the landscape island. Refer to [Figure 11.03.3 Curb Inlet Design](#). Wheel stops and other alternate landscape protections may be approved by the Zoning Officer to facilitate certain stormwater management facilities.

Figure 11.03.3 Curb Inlet Design

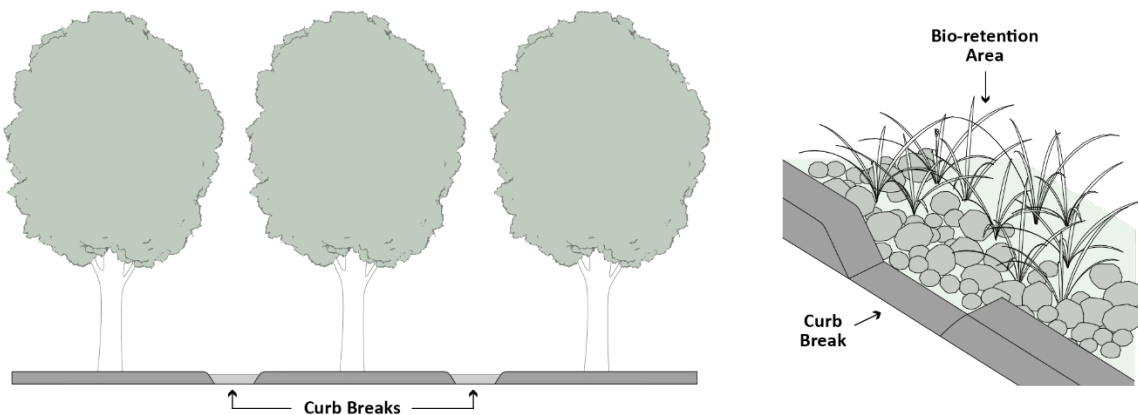

7. **Irrigation.** Permanent irrigation systems are not required but may be installed as recommended by a landscape architect or the Zoning Officer. All irrigation systems that are installed must be designed to minimize the use of water, and require certification that the system is water efficient (e.g. EPA WaterSense certified). Irrigation systems are not allowed in the right-of-way.
 8. **Utility Easements.** Landscape elements may be installed within utility easements, but shade trees are not permitted under overhead utilities. Existing shade trees located beneath overhead utilities must not be counted as existing vegetation in a Landscape Plan. If it is not practical to locate shade trees away from overhead utilities, the property owner will be responsible for maintaining the trees in such a manner that will not interfere with the overhead utilities and for replacing any trees that are damaged during utility repairs.
- B. **Planting Location and Visibility.** All landscape elements must be located in compliance with the visibility standards of [Section 8.05.C \(Visibility Obstruction\)](#) and [Section 10.06.D \(Visibility\)](#). Where practical, deciduous trees, shrubs and vines should be planted along the south and west sides of buildings to provide shade during the summer. Where practical, evergreens and other plant materials

should be concentrated on the north side of buildings in a manner which dissipates the effect of winter winds.

- C. Maintenance. All landscape elements must be maintained in good condition at all times to ensure healthy vegetation and an orderly appearance.
 - 1. Maintenance Responsibility. Landscape elements, such as vegetation and trees, irrigation systems, fences, and walls, must be properly maintained. The property owner is responsible for the maintenance, repair, and replacement of landscape elements to keep them in good condition for the lifespan of the development and/or parking lot.
 - 2. Surety. A letter of credit, escrow, performance bond, or other surety as approved by the Zoning Officer and subject to periodic inspection, equal to 110 percent of the value to purchase, plant, and maintain landscaping must remain in place for two years after installation to ensure proper maintenance in accordance with this Section.
 - 3. Establishment of Landscape Elements. All installed landscape elements must be watered, mulched, and replaced as needed until fully established.
 - 4. Ongoing Maintenance. All landscape elements must be maintained in good condition in perpetuity and must have a healthy, neat, and orderly appearance. Any landscape element that is removed due to disease, damage, death, or any other reason must be replaced within 30 days after the beginning of the growing season, in accordance with the requirements of this Section and the approved landscape plan.

11.04 Street Trees

- A. Applicability. Street trees aid in beautifying and shading the Village by providing consistent and appropriately spaced trees. The requirements of this Section apply to existing and proposed parkway areas adjacent to new developments that require approval of site plan review (see [Section 4.02 \(Site Plan Review\)](#)) or planned unit development (see [Section 5 \(Planned Unit Developments\)](#)).
- B. Street Tree Requirements.
 - 1. Frequency. Street trees must be installed at a minimum rate of one large shade tree per 40 linear feet of parkway. Trees must be selected for appropriate size at maturity for the subject parkway width, as determined by the Zoning Officer in consultation with the Village Engineer and Village Arborist. Trees must be spaced on center, or at a rate that matches the existing tree spacing pattern on adjacent parkways, whichever results in a greater density of tree plantings. Spacing may be adjusted to ensure adequate room for streetlights, signs, and utilities, with prior written approval by the Zoning Officer.
 - 2. Tree Wells. Tree wells must be utilized in locations where the sidewalk extends from the back of the curb to the lot line and there is no parkway present. Tree wells in sidewalks must provide a continuous trench with a depth of at least three feet to allow for better root growth and healthier trees. Tree wells must meet the standards of the Americans With Disabilities Act.

3. Jurisdictional Control. If a County or State has jurisdiction over a public right-of-way which prevents the installation of the required number of street trees, then the trees must instead be planted within the front yard of the adjacent zoning lots. These street trees are required in addition to other applicable landscape requirements.

11.05 Parking Lot Landscaping

A. Tree Canopy Coverage. Tree canopy coverage requirements must be met through tree plantings located within perimeter yards ([Section 11.05.B \(Parking Lot Perimeter Landscape\)](#)) and interior landscape islands ([Section 11.05.C \(Parking Lot Interior Landscape Islands\)](#)) such that shade canopy is provided for a minimum of 40 percent of the parking area hardscape, including all parking spaces, travel lanes, and other impervious areas not exempted by this Section. Refer to [Figure 11.05.1 Tree Canopy Coverage](#).

1. Calculation. Coverage credit for each tree must be calculated using the projected full canopy width of the tree at maturity. Coverage credit for trees planted in perimeter landscape or buffer yards will be credited in the amount that such plantings cover the parking area hardscape. Refer to the most recent Village of Montgomery Tree Species List for canopy coverage estimates.
2. Truck Parking, Storage, and Loading Area Exemption. Designated truck parking, storage and loading areas are exempt from the minimum tree canopy coverage requirement.
3. Solar Energy Systems. Any portion of the tree canopy coverage requirement may be met through installation of solar energy systems that comply with the standards of this Ordinance and provide shade to the parking area, with the approval of the Zoning Officer.
4. Modification of Requirements. The Zoning Officer may modify shading requirements for sites located under power lines or other obstructions that prohibit strict compliance, and grant credit for new off-site trees provided in lieu of required on-site plantings, where appropriate.

Figure 11.05.1 Tree Canopy Coverage

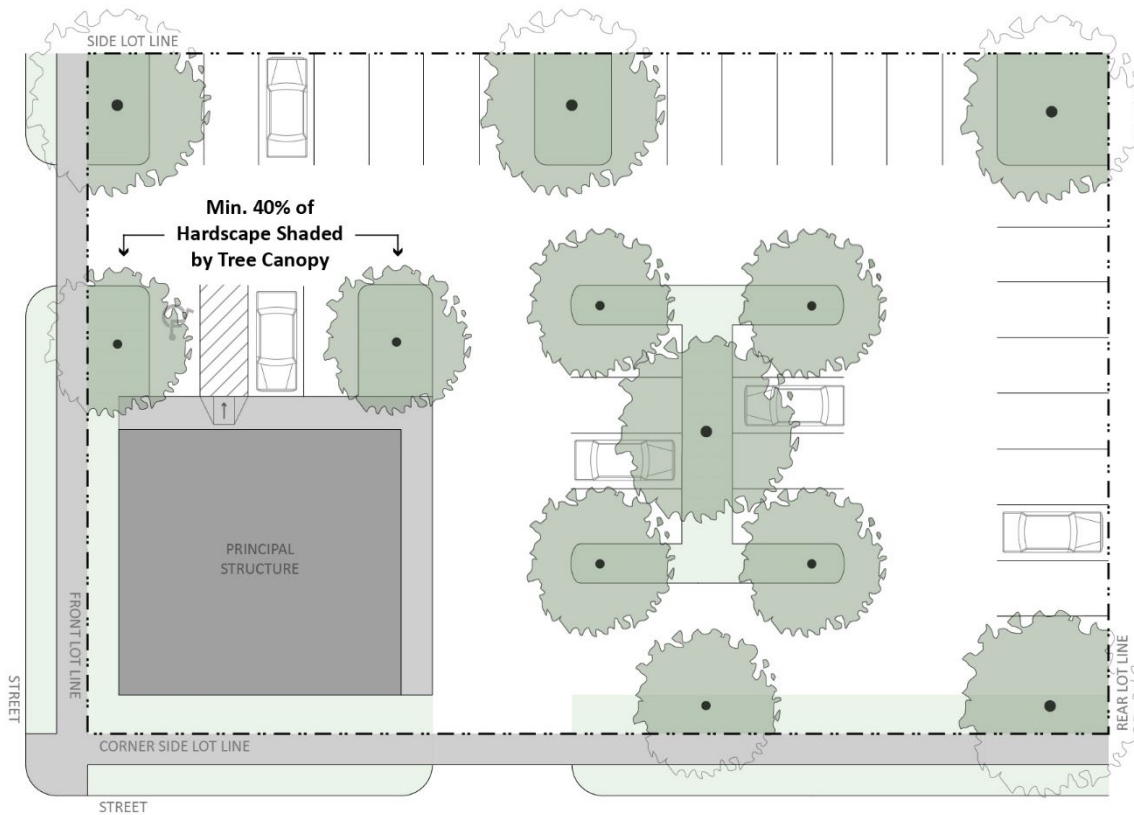

B. Parking Lot Perimeter Landscape. Refer to [Figure 11.05.2. Location of Landscape Requirements](#) and [Figure 11.05.3. Parking Lot Perimeter Landscape](#).

1. Location. Parking lot perimeter landscape requirements apply to lots in all zoning districts in which parking facilities are located adjacent to a lot line. Parking lot perimeter landscape must be located directly adjacent to the lot line.
2. Minimum Parking Lot Perimeter Landscape. A parking lot perimeter landscape with a minimum depth of eight feet is required along the length of the parking lot that abuts the lot line, excluding any driveways.
3. Landscape Elements. The parking lot perimeter landscape must meet all of the standards of [Section 11.03 \(Design, Installation, and Maintenance\)](#) and include the following:
 - a. Parking lot perimeter landscaping must provide seventy-five percent coverage along the adjacent lot lines and may include berms, ornamental trees, evergreen trees, shrubs, hedges, groundcovers, and perennials in clusters of seven plantings at a minimum.
 - b. One large shade tree per 30 linear feet of perimeter area, or one medium shade tree per 25 linear feet of perimeter area, or any combination thereof. Trees may be spaced evenly or grouped.
 - c. Any portion of the parking lot perimeter landscape not covered by hedges and trees must be planted with turf, clump or no-mow grasses, other perennial groundcover, or mulch.

4. Fence. Parking lot fencing may be installed to further screen the parking lot from view of the street and is subject to the following. Fences must be installed in accordance with [Section 9.03.C.14.c \(Construction, Design, and Appearance\)](#), unless otherwise specified in this section.
 - a. The fence must be located a minimum of two feet from the back of the parking lot curb to allow for vehicle overhang. The required parking lot perimeter landscape must be located between the fence and sidewalk to provide visual interest from the street.
 - b. The fence must be a minimum height of three feet and maximum height of four feet.
 - c. A paved opening with a minimum width of three feet must be provided at least every 50 feet to allow pedestrian access to the parking lot.
 - d. Ornamental metal, masonry, and wood are permitted fence materials. Chain link fences are prohibited.

5. Foundation Planting.
 - a. Location. Foundation planting must be installed for all multiple-unit dwellings and for non-residential development in the MD, B-1, B-2, M-1, and M-2 Districts. Foundation planting must be installed along the front and corner side facades of all buildings, except entrances and other areas where it may be impractical.
 - b. Size. Foundation planting must have a minimum depth of five feet.
 - c. Landscaping Materials. Foundation planting may include shade or ornamental trees, native or ornamental grasses, shrubs, perennials, turf, or other live groundcover.

Figure 11.05.2 Location of Landscape Requirements

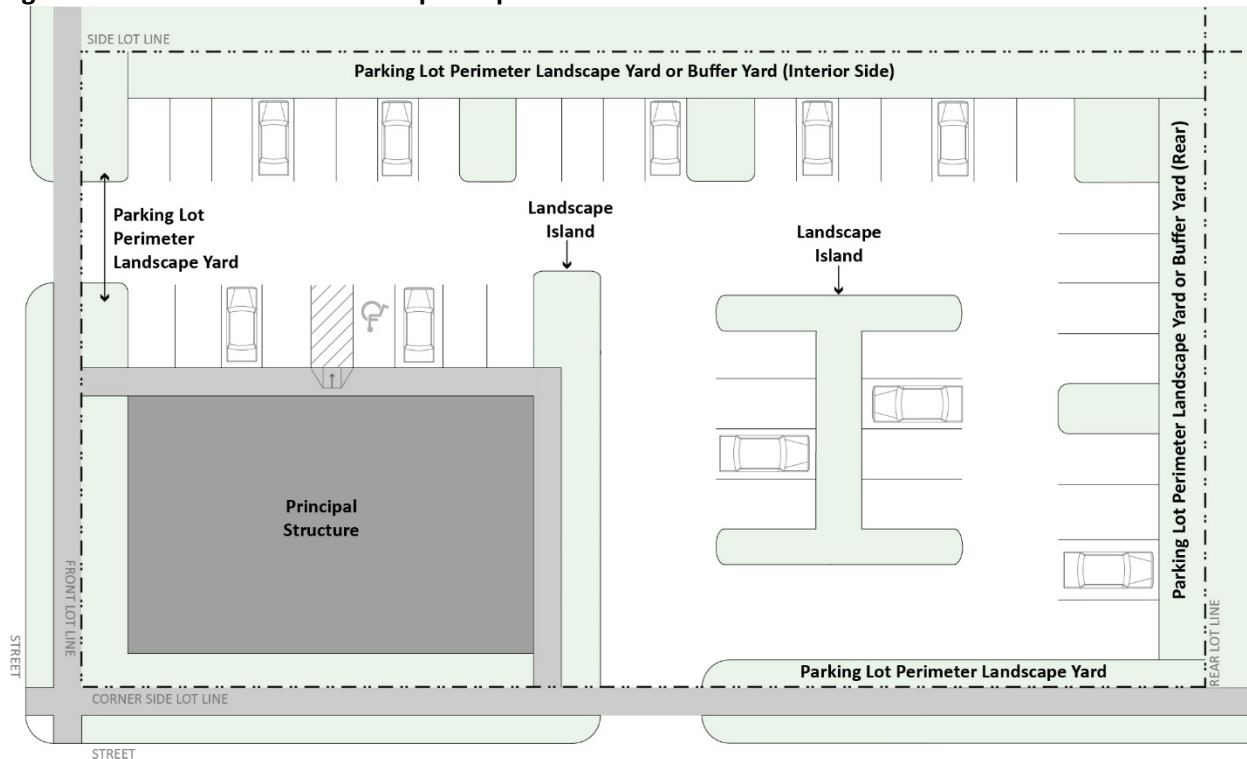
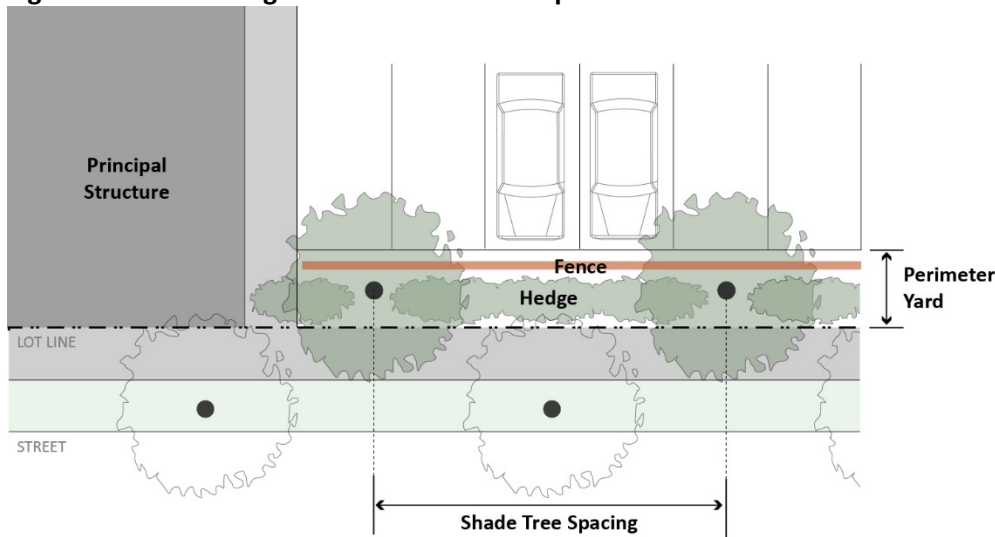

Figure 11.05.3 Parking Lot Perimeter Landscape



C. Parking Lot Interior Landscape Islands. Refer to [Figure 11.05.4 Parking Lot Interior Landscape Islands](#) and [Figure 11.05.2 Location of Landscape Requirements](#).

1. Spacing. All rows of parking must be terminated by an end landscape island or landscape area. Parking islands are required every 15 spaces between end landscape islands or landscape areas.
2. Size. For a single parking row, the landscape island must have a minimum length equal to the length of the adjacent parking space and a minimum area of 100 square feet. When double rows of parking are provided, the required landscape islands must have a minimum length equal to the total length of the adjacent parking spaces and a minimum area of 200 square feet.
3. Alternate Configuration. In conjunction with landscape plan approval (see [Section 11.01.D \(Landscape Plan\)](#)), the Zoning Officer may permit a different configuration of landscape islands to allow for more efficient site design or to permit larger landscape areas. Regardless, the overall area and number of plantings required for landscape islands pursuant to this Section must be met.
4. Trees. A minimum of one shade tree must be provided per landscape island. Landscape islands provided for double rows of parking must include a minimum of two shade trees.
5. Groundcover. A minimum of 80 percent of each landscape island must be planted with ornamental or native grasses, perennials, turf, or other live groundcover. Shrubs are not permitted in landscape islands.

Figure 11.05.4 Parking Lot Interior Landscape Islands

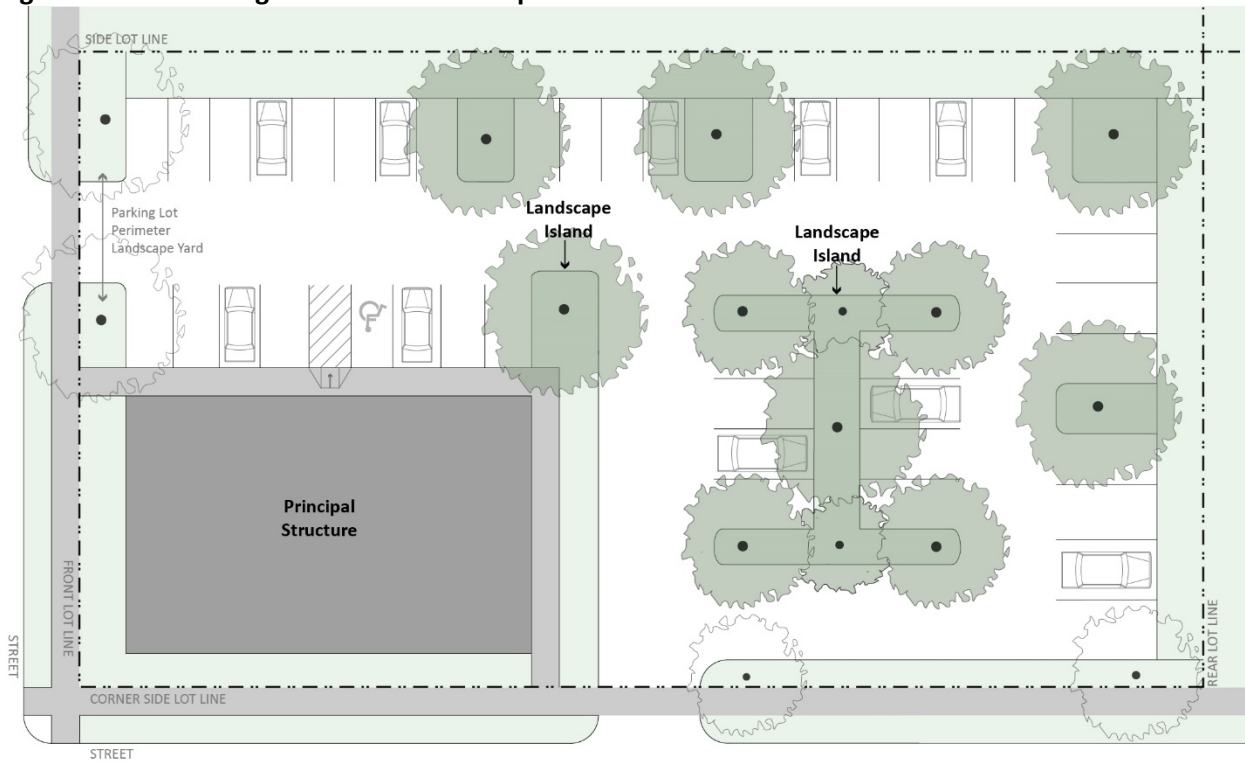

11.06 Buffer Yards

A. Applicability. Buffer yards are used to separate more intensive zoning districts and uses from less intensive zoning districts and uses. A buffer yard is required adjacent to lot lines where the proposed development meets one or more of the following criteria. For the purposes of this Section, lots are not considered directly adjacent to one another if an alley or other right-of-way separates the lots. Any reconstruction of existing parking lots of less than 15 parking spaces is exempt from buffer yard requirements. Refer to [Figure 11.05.2 Location of Landscape Requirements](#) and [Figure 11.06.1 Buffer Yards](#).

1. Non-Residential District. A buffer yard is required if the lot is located in the B-1, B-2, M-1, or M-2 District and is directly adjacent to a lot located in the R-1, R-2, R-3, R-4, or R-5 District.
2. Non-Residential Use in Residential Districts. A buffer yard is required for lots located in the R-1, R-2, R-3, or R-4 District if the lot contains a non-residential use and is adjacent to a residential use. Parks are exempt from this requirement.
3. R-4 and R-5 Districts. A buffer yard is required for lots with multiple unit dwellings in the R-4 and R-5 District if the lot is located adjacent to a single-unit dwelling or a two-unit dwelling.

B. Buffer Yard Requirements.

1. Location. The buffer yard must be located directly adjacent to the affected interior side and/or rear lot line, along the entire length of the lot line.

2. Minimum Buffer Yard depth. A buffer yard must have a minimum depth of 10 feet. Landscape that is provided as part of required parking lot perimeter landscape, see [Section 11.05.B \(Parking Lot Perimeter Landscape\)](#), may count towards the minimum buffer yard requirement.
3. Landscape Elements. The buffer yard must include the following:
 - a. A continuous hedge comprised of individual small shrubs that are adaptable to being grown as a hedge, with a minimum width of 24 inches, spaced 36 inches on center.
 - b. One evergreen tree for every 10 linear feet of buffer area. Trees may be spaced evenly or grouped.
 - c. Any portion of the buffer yard not covered by hedges and trees must be planted with turf, clump, or no-mow grasses, perennial groundcover, or mulch.
 - d. In residential and commercial zoning districts, a continuous hedge of individual shrubs may be allowed instead of providing evergreen trees within a buffer yard with prior written Zoning Officer approval, provided that the hedge height at maturity is taller than 42 inches.
4. Fence. Fences in buffer yards are required in the M-1 and M-2 District when the subject lot is directly adjacent to a lot located in the R-1, R-2, R-3, R-4, or R-5 District. Fences in buffer yards are optional in all residential and business zoning districts, and in manufacturing zoning districts when the subject lot is not adjacent to a lot located in a residential district. Fences must be installed in accordance with [Section 9.03.C.14.c \(Construction, Design, and Appearance\)](#), unless otherwise specified in this Section.
 - a. Location. The fence must be located along the entire length of the affected interior side or rear lot line.
 - b. Height. Buffer yard fences must be eight feet in height.
 - c. Type. Solid fences are required for buffer yards.

Figure 11.06.1 Buffer Yards

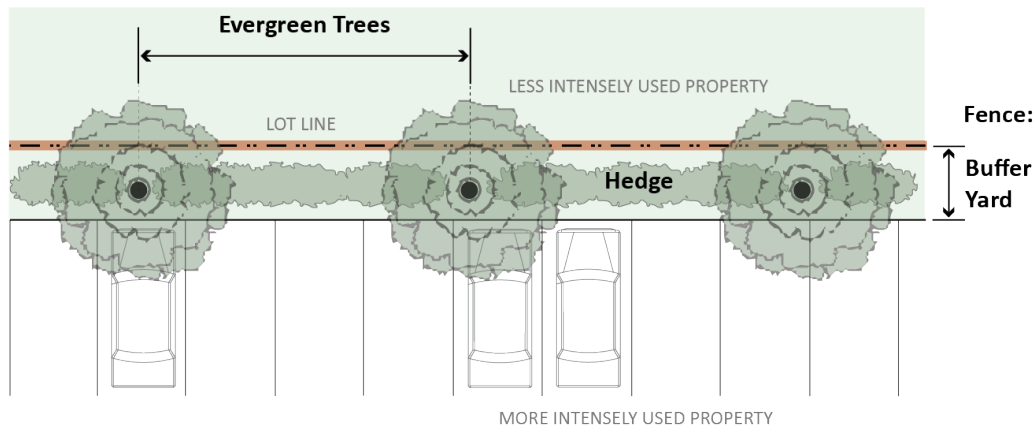

11.07 Screening Requirements¹¹

- A. Applicability. The requirements of this Section apply to refuse areas, ground-mounted mechanical equipment, ground-mounted utilities, outdoor storage areas, and off-street loading areas to screen them from view of the street and adjacent lots.
- B. Refuse Area, Ground-Mounted Mechanical Equipment, Ground-Mounted Utility, and Outdoor Storage Area Screening Requirements. Refer to [Figure 11.07.1 Refuse Area, Ground-Mounted Mechanical Equipment, Ground-Mounted Utility, and Outdoor Storage Area Screening](#).
1. Location. Refuse areas must be located in the interior side yard or rear yard. Refer to [Section 9.02.B.21 \(Outdoor Storage Area\)](#) and [Section 9.03.C.22 \(Mechanical Equipment\)](#) for location requirements for outdoor storage and ground-mounted mechanical equipment standards.
 2. Walls and Fences. The refuse area or outdoor storage area must be screened by walls or fence as specified in this section.
 - a. Refuse Areas: Refuse areas must be completely screened by a masonry wall on three sides, and an opaque gate on the fourth side. The wall of a principal structure may serve as a screening wall.
 - i. Height. The fence or wall must be a minimum of six feet (6') in height, but must not exceed eight feet (8') in height.
 - ii. Complementary Design. Screening elements must complement the architectural style of the primary building on site and use building materials similar to those used for the primary building.
 - iii. Gate. The enclosure of the refuse area must be gated, and remain closed except during times off refuse deposit or collection.
 - b. Outdoor Storage Areas: Outdoor storage areas must be completely enclosed by a wall or fence a minimum of six feet (6') in height. The fence shall be a solid fence with no more than 25% open spaces. Fences must be installed in accordance with [Section 9.03.C.14.c \(Construction, Design, and Appearance\)](#), unless otherwise specified in this section.
 - c. Ground Mounted Utility: Ground mounted utility must be enclosed by a wall or fence a minimum of six feet (6') in height. Fences must be installed in accordance with [Section 9.03.C.14.c \(Construction, Design, and Appearance\)](#).
 3. Landscape Elements. Landscaping shall be installed as outlined in this section to provide screening and to soften the aesthetic impact of these areas on adjacent property and from adjacent public rights-of-way.
 - a. Refuse Areas: Landscape shrubs or native grasses must be installed on two sides of the area, with plantings located between the wall and back of curb, and screening the full length of each side. Installed shrubs must form a continuous hedge comprised of individual small shrubs of an appropriate species that are adaptable to being grown as a hedge, with a minimum width of 24 inches, spaced 36 inches on center.
 - b. Outdoor Storage Areas: Landscaping shall be provided along the exterior perimeter of the required fence or wall consisting of evergreen and deciduous shrubs. If materials to be stored outdoors are in excess of eight feet (8') in height, then landscape screening shall be provided along the outside perimeter of the fence or wall, equal to or exceeding the

¹¹ Amended per Ordinance 1929.

height of the materials to be stored outdoors to provide 75% coverage along the perimeter of the storage area. Landscaping must include a mix of evergreen trees, shade trees and ornamental trees. Outdoor storage areas with a line of sight from the public right-of-way shall be required to be bermed and to provide additional evergreen screening to provide 50% coverage along the perimeter visible from the public right-of-way.

- c. Ground Mounted Mechanical Equipment or Ground Mounted Utility: Ground mounted mechanical equipment or ground mounted utility shall be screened with appropriate plantings to soften the aesthetic impact of these areas on adjacent property and from adjacent public rights-of-way. The Zoning Officer shall decide the acceptable amount of screening during the site plan review process.
- C. Off-Street Loading Area Screening Requirements. The area adjacent to any off-street loading areas must include buffering and landscaping in accordance with [Section 11.05.B \(Parking Lot Perimeter Landscape\)](#).

Figure 11.07.1 Refuse Area, Ground-Mounted Mechanical Equipment, Ground-Mounted Utility, and Outdoor Storage Area Screening

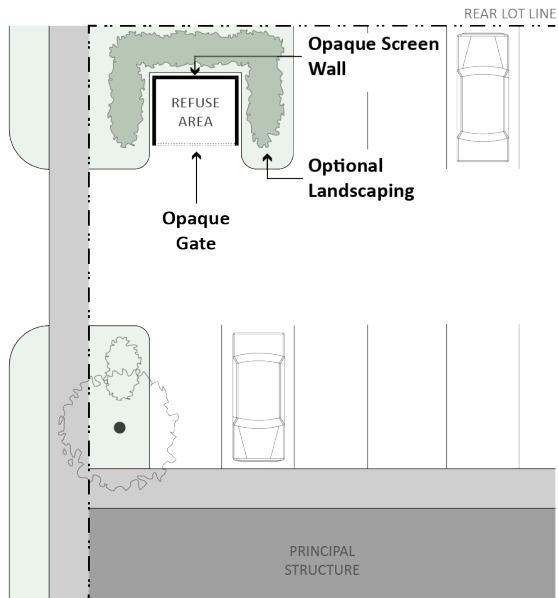

11.08 Landscaped Setbacks

- A. **Applicability.** Landscaped setbacks must be provided in accordance with [Table 11.08.1 Landscaped Setbacks](#), to improve the safety, appearance and environment along major transportation arterials and collector streets in the Village. Landscaped setbacks must be provided and maintained on all zoning lots except those used for single-family dwellings.
- B. **County and State Roadways.** The landscaped setbacks must meet the requirements of Kane and Kendall Counties for setbacks from county and state roadways.
- C. **Zoning District Setbacks.** In cases where a greater setback is required by the zoning district regulations of [Section 8 \(Zoning District Regulations\)](#), the greater setback requirement applies.
- D. **Landscaping Requirements.** The landscaped setback must comply with the following standards.
 1. **Live Landscaping.** The landscaped area must consist of at least seventy-five percent live landscaping, such as shade trees, evergreen trees, ornamental trees, shrubs, ornamental grasses, perennials, turf, and other live ground cover.
 2. **Landscaped Setback.** No buildings, structures, parking areas, or fences over four feet in height are permitted within the landscaped setback. The landscaped setback may include signs, sidewalks, and driveways.

Table 11.08.1 Landscaped Setbacks

Street Name	Minimum Depth of Landscaped Setback
Ashland Avenue	10 feet
Aucutt Road	20 feet
Dickson Road	30 feet
Douglas Road	20 feet
Galena Road	50 feet
Hill Avenue	20 Feet
Illinois Route 25	30 feet
Illinois Route 31	30 feet
Jericho Road	35 feet
Montgomery Road	10 feet
Orchard Road	35 feet
U.S. Route 30 (east of Orchard Road)	30 feet
U.S. Route 30 (west of Orchard Road)	50 feet
U.S. Route 34	30 feet
Newly Designated Collectors	20 feet

11.09 Outdoor Lighting

- A. Applicability. Outdoor lighting standards prevent light trespass, promote energy efficiency, minimize light pollution, and enhance public safety. The requirements of this Section apply to all new or replacement outdoor lighting, with the exception of unshielded lighting for holiday decorations or permitted temporary uses as established in [Section 9.04 \(Temporary Structures and Uses\)](#). The Zoning Officer may impose reasonable restrictions on the use of such lighting for temporary uses as necessary to protect the health, safety, and welfare of the public.
- B. General Requirements.
1. Photometric Plan. A photometric plan prepared by a professional must be approved by the Zoning Officer prior to installation of outdoor light fixtures for non-residential uses.
 2. Prohibited Lighting. Any outdoor lighting that may be confused with a traffic control device is prohibited except if it is authorized by federal, state, county, or local government. Flashing lights, strobe lights, and laser lights are prohibited.
 3. Design That Prevents Glare. All lighting must be designed to prevent glare and interference with residential lots and motor vehicle, bicycle, and pedestrian traffic.
 4. Fixtures. All new and replacement outdoor lighting must employ full cut-off or fully shielded fixtures.
 5. Façade Illumination. Building façade illumination must be limited to fully shielded fixtures directed towards the façade. All light from such fixtures must be concentrated on the exterior wall surface of the building being illuminated.

6. Automatic Lighting Controls. All outdoor lighting on non-residential lots must be controlled by a photo sensor, occupancy sensor, or timer to automatically reduce outdoor lighting when sufficient daylight is available, and to automatically extinguish lights no more than one hour following the close of business, excluding security lighting.
7. Energy-Efficient Technology. The use of Light Emitting Diodes (LED) or similar technology is encouraged.

C. Illumination Standards.

1. Illumination.
 - a. Non-Residential Uses. Outdoor lighting must not exceed one foot-candle at any point on a lot line for a lot containing a non-residential use, unless otherwise specified in this Ordinance. Manufacturing uses that operate overnight may exceed one foot-candle of illumination with prior approval of the Zoning Officer. Outdoor lighting must not exceed one-half foot-candle at any point on a lot line for a lot adjacent to a residential use, in accordance with [Section 11.09.C.1.b \(Residential Uses\)](#), unless otherwise specified in this Ordinance.
 - b. Residential Uses. Outdoor lighting must not exceed one-half foot-candle at any point on a lot line for a lot containing a residential use, unless otherwise specified in this Ordinance.
 - c. Recreational Facilities. The average outdoor lighting level for recreational uses must not exceed 50 foot-candles, with the exception of golf-related facilities, which are limited to a maximum average lighting level of five foot-candles for courses and 20 foot-candles for driving ranges.
 - d. Sign Illumination. Sign illumination must conform to the provisions of [Section 12 \(Signs\)](#).
2. Height. The maximum height of light poles and building-mounted lighting is established in this Section unless otherwise required by [Chapter 6 \(Building and Construction\) of the Municipal Code](#).
 - a. Non-Residential Uses. Light poles and building-mounted fixtures must not exceed 20 feet in height in business districts and 30 feet in manufacturing districts. Light poles for educational facilities or outdoor recreational facilities must not exceed 60 feet in height. Outdoor lighting for all outdoor recreation areas is subject to review of building permit and photometric plan.
 - b. Residential Uses. Light poles must not exceed 20 feet in height for residential uses. Building-mounted fixtures, including under-soffit lighting, must not exceed 10 feet in height.

SECTION 12: SIGNS

[12.01 Purpose](#)

[12.02 General Construction and Design Standards](#)

[12.03 Sign Measurement Standards](#)

[12.04 Master Sign Plan](#)

[12.05 Permanent Signs](#)

[12.06 Temporary Signs](#)

[12.07 Prohibited Signs](#)

12.01 Purpose

- A. Purpose. The purpose of this Section is to establish regulations to govern the display, design, construction, installation, maintenance, alteration, and removal of signs. The regulations in this Section:
1. Promote and protect the health, safety, and general welfare of the Village from signs that are unsafe, conflict with traffic control devices, or distract motorists, bicyclists, or pedestrians.
 2. Enhance economic development and community activities by promoting the reasonable, orderly, and effective display of signs, and encouraging better communication with the public.
 3. Improve the appearance of signs to create a more attractive economic climate in the Village.
 4. Ensure that signs are compatible with surrounding land uses and architecture.
 5. Discourage signs that are unsightly, inappropriate, or excessive in area or number.
 6. Ensure that the right to free speech is protected through the display of signs that are content-neutral to greatest degree possible.

12.02 General Construction and Design Standards

- A. General Requirements. All signs must meet the construction and design standards of this Section and of [Chapter 6 \(Buildings and Construction\) of the Municipal Code](#).
- B. Unlisted Similar Sign. If a sign is not listed in this Section, but is similar in nature and impact to a sign permitted within a zoning district, the Zoning Officer may interpret the unlisted sign as a permitted sign.
- C. Installation. All signs must be installed so that necessary supports and braces are an integral part of the sign design.

D. Location. All signs must comply with the following standards.

1. Public Property. Signs may only be placed on public property by a government agency, as authorized by this Section, or by the Zoning Officer. Any sign placed on public property without authorization may be removed without notice.
2. Private Property. Signs may only be placed on private property with prior consent of the property owner and, if applicable, pursuant to an approved sign permit issued by the Village in accordance with [Section 4.09 \(Sign Permit\)](#).
3. Building Exterior. A sign mounted on the exterior of a building must not conceal any windows, doors, fire escapes, or unique architectural features. This standard does not apply to window signs.
4. Visibility Obstruction. Minimum clear sight distance at all intersections must be in accordance with [Section 8.05.C \(Visibility Obstruction\)](#) and other applicable guidelines, whichever is greater.

E. Illumination. All signs must comply with the following illumination standards.

1. Electrical Components. All electrical components used in the construction of a sign must be installed and maintained as required by [Chapter 6 \(Buildings and Construction\) of the Village Code](#).
2. Light Level.
 - a. LED Lighting. The light level of an illuminated sign lit with LED bulbs must be no greater than 5,000 nits of luminance from dawn to dusk, and no greater than 500 nits of luminance from dusk to dawn.
 - b. Non-LED Lighting. The light level of an illuminated sign lit with bulbs other than LED bulbs must be no greater than one foot-candle at any time of day as measured at the curb line.
3. Direct Light and Glare. All sign illumination must be located, shielded, and directed to illuminate only the sign face and to prevent direct light or glare from being cast upon adjacent rights-of-way and surrounding properties. Neon tubing for neon signs and bare bulbs for marquee signs must be exempt from this requirement. No sign illumination may be combined with reflective materials, such as mirrors, polished metal, or highly-glazed tiles, which would increase glare.
4. Steady Illumination. Illuminated signs must be illuminated by steady, stationary, fully shielded light sources concentrated on the face of the sign so as not to cause glare.
5. Neon Signs. Marquee signs and window signs may be illuminated with neon. Window signs that are illuminated with neon are allowed in accordance with the standards of [Section 12.05.B.12 \(Window Signs\)](#). Neon tubing must not be used to trim windows or architectural features.

F. Maintenance, Inspection, and Removal.

1. Maintenance. All signs, support structures, background, anchors, wiring systems, and the area immediately adjacent to signs must be regularly maintained, including cleaning, painting, and repairs to prevent rusting, rotting, illegible text, or other deterioration. All broken or missing parts must be promptly replaced. No sign may be constructed, erected, or maintained in a manner that is unsafe or a danger to the public.
2. Inspection. The Village may inspect any sign regulated by this Section at any time to determine whether the sign is in need of repair or removal, or whether it is in conformance with the provisions of this Section.
3. Removal of Unsafe Signs. Any sign that is an immediate peril to people or property may be removed by the Village without prior notice to the owner thereof. The cost of removal will be billed to the property owner.
4. Removal of Signs. When a use ceases to operate for 15 consecutive days, any sign associated with the use must be removed or replaced within 30 days after the initial 15-day period.
 - a. When a wall sign is removed, all surfaces of the wall must be restored to match the existing wall surface.
 - b. When a manually changeable copy sign is removed, a blank panel must be installed until a new sign panel is installed.

12.03 Sign Measurement Standards

The following standards control the measurement of sign area and sign height.

A. Measurement of Sign Area. Refer to [Figure 12.03.1 Sign Area Measurement](#).

1. Signs with Backgrounds. For signs mounted upon a background, sign area is measured as the entire area of the sign face or background of the sign used to distinguish the sign from the structure upon which it is placed, unless otherwise noted in this Section. Sign area does not include any supporting framework or bracing, unless such framework or bracing is part of the message or sign face.
2. Signs with Freestanding Letters and/or Logos. For signs consisting of freestanding letters and/or logos, sign area is measured as the total area of the smallest geometric shapes that will enclose each word and graphic in the display. Sign area does not include any supporting framework or bracing, unless the framework or bracing is part of the message or sign face.

Figure 12.3.1. Sign Area Measurement



Measuring a Sign on a Background

Measuring a Sign with Freestanding Letters and/or Logos

B. Measurement of Sign Height.

1. **Ground-Mounted Signs.** The height of a ground-mounted sign is the vertical distance measured from grade to the highest point of the sign.
2. **Building-Mounted Signs.** The height of a building-mounted sign is the vertical distance from the base of the sign face to the highest point of the sign face, unless otherwise noted in this Section.

12.04 Master Sign Plan

- A. **Applicability.** A master sign plan approved by the Zoning Officer is required for signs installed in non-residential developments with three or more tenants. A sign permit will not be issued for a sign in a multi-tenant development unless it conforms to the approved master sign plan in accordance with [Section 4.09 \(Sign Permit\)](#). For existing multi-tenant developments, a master sign plan is required if the applicant proposes to modify 50 percent or more of the existing signs within a 12-month period.
- B. **Contents.** The master sign plan must indicate the type, number, location, materials, and dimensions of all signs in the development. The master sign plan must also include any other information necessary to determine whether the proposed signs comply with the sign regulations of this [Section 12 \(Signs\)](#).
- C. **Design Standards.** The master sign plan must describe and illustrate a consistent pattern of signage in the development. All signs within the development must have the following design elements in common:
 1. Mounting height on the building for wall signs.
 2. Materials.
 3. Sign type.
- D. **Master Sign Plan Approval and Amendments.** The Zoning Officer is authorized to approve master sign plans and amendments to master sign plans. Amendments to master sign plans may be approved by the Zoning Officer only if all signs approved under the existing master sign plan are in conformance, or are brought into conformance, with the provisions of the amended master sign plan.

12.05 Permanent Signs

- A. Permanent Signs Allowed Without Sign Permit. The following types of permanent signs are allowed without a sign permit and are allowed in all zoning districts provided that they comply with the following standards.
1. Entry Door Signs.
 2. Flags. Flags must not exceed 40 square feet in area with a maximum of three flags per zoning lot.
 3. Government Signs.
 4. Hanging Signs. One hanging sign is allowed per zoning lot in the MD, B-1, and B-2 Districts. Hanging signs must not exceed four square feet in area. Hanging signs must be located at least seven feet above grade.
 5. Headstones.
 6. Historical Markers. Historical markers must be constructed of bronze or other similar materials, and must not exceed five square feet in area per sign.
 7. Parking Lot Signs. Parking lot signs must not exceed six square feet in area per sign.
 8. Residential Signs. One wall or window sign is allowed per lot in a residential zoning district. Residential signs must not exceed two square feet in area and must not be illuminated.
 9. Street Address Signs. Street address signs must not be internally-illuminated. Street address signs must not exceed two square feet in area in the R-1, R-2, and R-3 Districts, three square feet in area in the R-4 and R-5 Districts and six square feet in area in non-residential zoning districts.
 10. Warning Signs. Two warning signs are allowed per zoning lot. Warning signs must not exceed two square feet in area per sign in residential zoning districts and six square feet in area in all other zoning districts.
- B. Permanent Signs with Permit Requirement. The following permanent signs require a sign permit, in accordance with [Section 4.09 \(Sign Permit\)](#), and must comply with the following standards. [Table 12.05.1 Permanent Signs Permitted by District](#) establishes the permitted districts for the listed sign types.

Table 12.05.1 Permanent Signs Permitted by District

Sign Type	District							
	A	R-1, R-2, R-3	R-4, R-5	MD	B-1	B-2	M-1	M-2
A-Frame and T-Frame Signs (Section 12.05.B.1)		•	•	•	•	•	•	•
Awning Signs (Section 12.05.B.2)		•	•	•	•	•	•	•
Canopy-Mounted Signs (Section 12.05.B.3)		•	•	•	•	•	•	•
Drive-Through Signs (Section 12.05.B.4)						•		
Driveway Access Signs (Section 12.05.B.5)						•	•	•
Electronic Message Signs (Section 12.05.B.6)		•	•			•		
Manually Changeable Copy Signs (Section 12.05.B.7)		•	•	•	•	•	•	•
Marquee Signs (Section 12.05.B.8)				•	•	•		
Monument Signs (Section 12.05.B.9)	•	•	•	•	•	•	•	•
Projecting Signs (Section 12.05.B.10)				•	•	•		
Wall Signs (Section 12.05.B.11)		•	•	•	•	•	•	•
Window Signs (Section 12.05.B.12)		•	•	•	•	•	•	•
• = Permitted subject to the requirements of this Section 12 (Signs) .								

1. A-Frame and T-Frame Signs. Refer to [Figure 12.05.1 A-Frame Sign](#) and [Figure 12.05.2 T-Frame Sign](#).
 - a. Location.
 - (1) A-Frame and T-Frame signs are allowed in the MD, B-1, B-2, M-1, M-2 Districts, and in all residential districts for non-residential uses and multiple-unit dwelling uses.
 - (2) A-Frame and T-Frame signs are permitted on a public sidewalk in the Mill District in locations where the sign provides at least four feet of unobstructed sidewalk.
 - b. Quantity. One A-Frame or T-Frame sign is permitted per building tenant per street frontage.
 - c. Size.
 - (1) Area. The total area must not exceed 12 square feet per sign face.
 - (2) Height. The total height must not exceed four feet in height.
 - d. Illumination. Illumination of A-Frame and T-Frame signs is prohibited.
 - e. Display Standards. A-Frame and T-Frame signs must be movable and shall only be displayed during hours of operation of the establishment.

Figure 12.05.1 A-Frame Sign

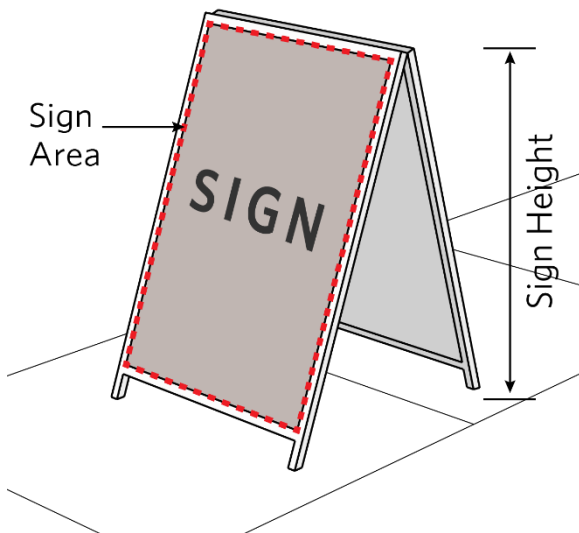

A-Frame Sign

Figure 12.05.2 T-Frame Sign

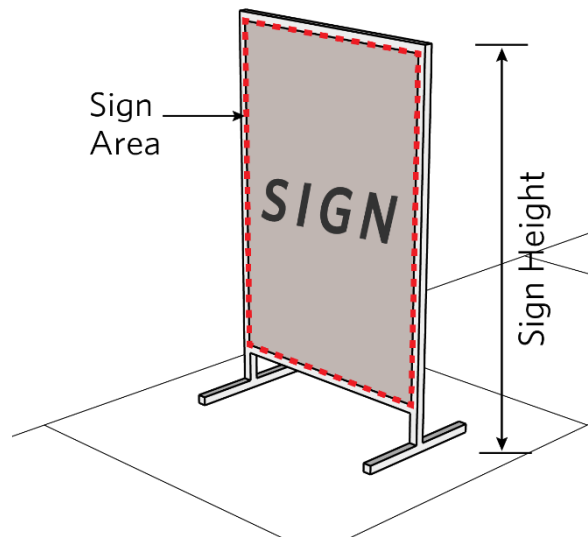

T-Frame Sign

2. Awning Signs. Awnings that do not display signs are not subject to the regulations of this Section. Refer to [Figure 12.05.3. Awning Signs](#).
 - a. Location.
 - (1) Awning signs are allowed in the MD, B-1, B-2, M-1, M-2 Districts, and in all residential districts for non-residential uses and multiple-unit dwelling uses.
 - (2) An awning sign may project from the front, side, rear, or corner side façade of the building to which it is attached.
 - (3) An awning sign may project over the lot line, but must not project more than eight feet from the façade of the building to which it is attached and must be at least two feet from the curb of a street or the edge of a driveway.
 - (4) No portion of the awning on which the awning sign is attached may be located lower than seven feet above grade.
 - (5) The height of an awning containing an awning sign must not exceed 16 feet as measured from grade to the highest point of the awning.
 - (6) Awning signs must be generally aligned with awning signs that are attached to adjacent buildings to maintain a sense of visual continuity.
 - b. Quantity. One awning sign is allowed per awning face and per awning apron.
 - c. Size. An awning sign must not exceed six feet in height. An awning sign must not exceed 75 percent of the area of the awning face or the awning apron for the awning on which it is located. For awnings extending across the building frontage of more than one ground floor tenant, the awning area for each tenant is measured from the limits of each building frontage. Awning signs are exempt from the measurement standard of [Section 12.03.A.1 \(Signs with Backgrounds\)](#) and follow the measurement standard of [Section 12.03.A.2 \(Signs with Freestanding Letters and/or Logos\)](#).
 - d. Illumination. Externally illuminated awning signs are allowed only in accordance with [Section 12.02.E \(Illumination\)](#). Awning signs must not be back-lit.
 - e. Display Standards.
 - (1) Awning signs must be displayed on awnings constructed out of durable, weather-resistant material such as canvas, nylon, vinyl-coated fabric, or metal.
 - (2) Awning signs must not be displayed on round, arched, bubble, box, or waterfall awnings.

Figure 12.05.3 Awning Signs



3. Canopy-Mounted Signs. Refer to [Figure 12.05.4 Canopy-Mounted Signs](#).
- a. Location.
 - (1) Canopy-mounted signs are allowed in the MD, B-1, B-2, M-1, M-2 Districts, and in all residential districts for non-residential uses and multiple-unit dwelling uses.
 - (2) The canopy upon which the canopy-mounted sign is displayed may project from the front, side, rear, or corner side façade of the building to which it is attached.
 - (3) A canopy-mounted sign may project over the lot line, but must not project more than four feet from the façade of the building to which it is attached.
 - (4) The canopy upon which the canopy-mounted sign is displayed must be located at least eight feet above grade, and the canopy-mounted sign must not extend below the lowest point of the canopy on which it is displayed.
 - (5) Canopy-mounted signs must be generally aligned with canopy-mounted signs that are attached to adjacent buildings to maintain a sense of visual continuity.
 - b. Quantity. One canopy-mounted sign is allowed per tenant entrance.
 - c. Size.
 - (1) Area. The total area of canopy-mounted signs must not exceed one square foot of sign area per linear foot of the building façade to which the sign will be affixed.
 - (2) Height. Canopy-mounted signs must not exceed two feet in height as measured from the top of the canopy.
 - d. Illumination. Internally and externally illuminated canopy-mounted signs are allowed only in accordance with [Section 12.02.E \(Illumination\)](#).
 - e. Gas Station Canopies. Gas station canopies may have one sign per canopy façade, the total area of which must not exceed 40 square feet in area per sign. Gas station canopy signs must not exceed four feet in height and must not project above or below the canopy. Externally illuminated gas station canopy signs are allowed only in accordance with [Section 12.02.E \(Illumination\)](#).

Figure 12.05.4 Canopy-Mounted Signs

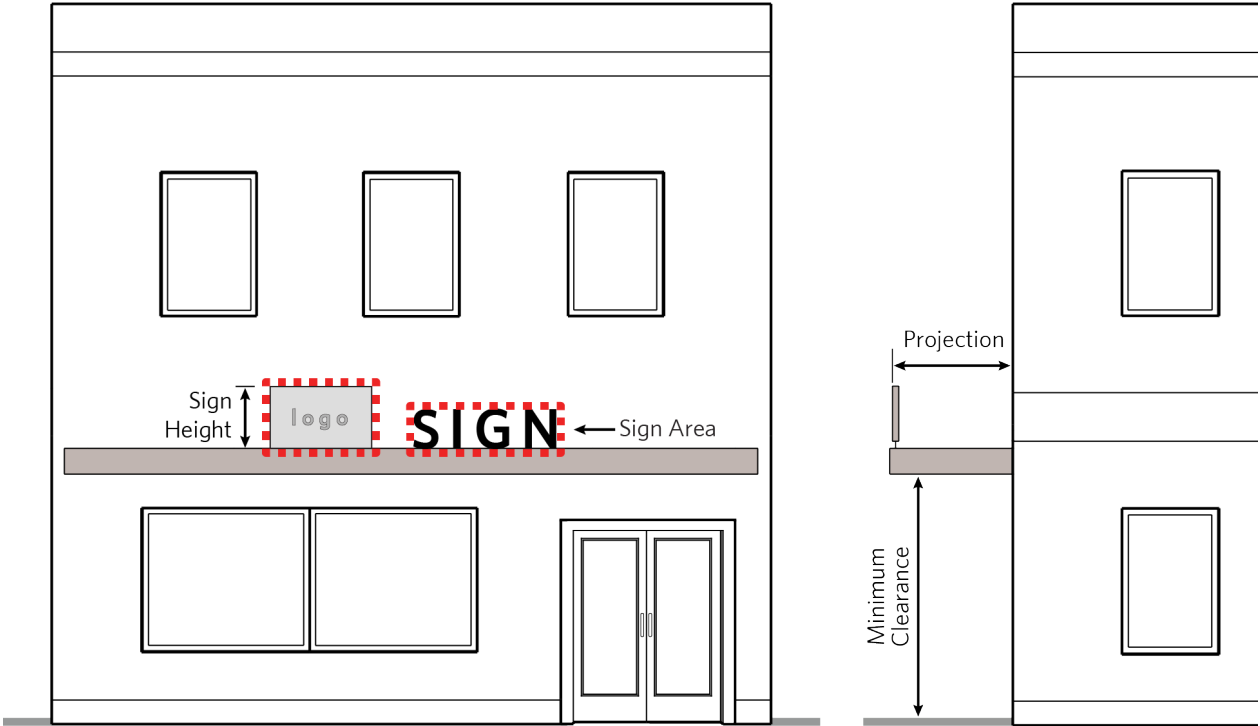

Front View

Side View

4. Drive-Through Signs. Refer to [Figure 12.05.5 Drive-Through Signs](#).
- a. Location.
 - (1) Drive-through signs are allowed for drive-through establishments located in the B-2 District.
 - (2) Drive-through signs must be located a minimum of 15 feet from the lot line of any lot in a residential zoning district.
 - b. Quantity. One primary drive-through sign and one secondary drive-through sign is allowed per drive-through lane.
 - c. Size. Together, the primary and secondary drive-through signs must not exceed 50 square feet in area and six feet in height.
 - d. Illumination.
 - (1) Internally illuminated drive-through signs are allowed only in accordance with [Section 12.02.E \(Illumination\)](#).
 - (2) Drive-through signs may include a speaker and an electronic screen to display information to customers.
 - e. Display Standards. Drive-through signs must be displayed as wall signs or monument signs. In the event of a conflict between the provisions of [Section 12.05.B.4 \(Drive-Through Signs\)](#) and the applicable provisions of [Section 12.05.B.9 \(Monument Signs\)](#), the provisions of this [Section 12.05.B.4 \(Drive-Through Signs\)](#) control.

Figure 12.05.5 Drive-Through Signs

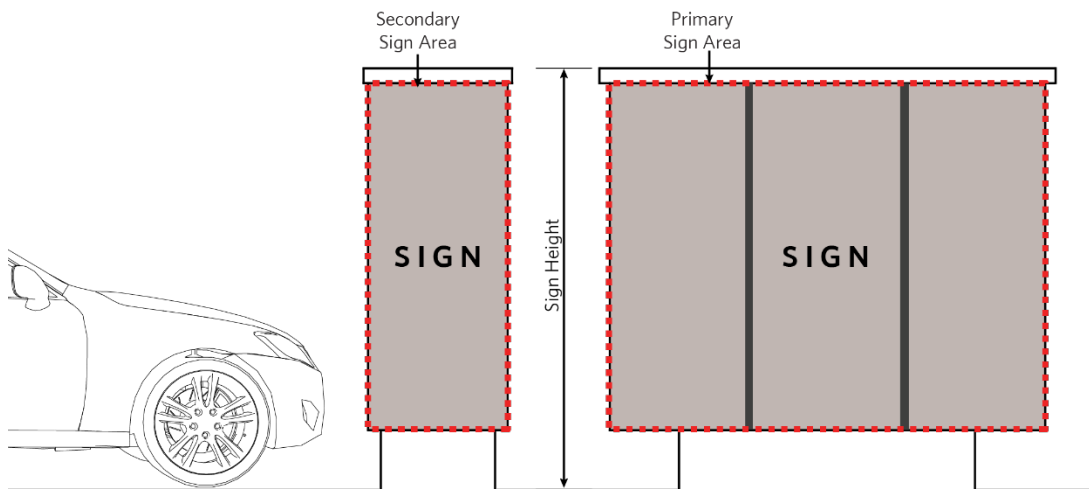

5. Driveway Access Signs. Refer to [Figure 12.05.6 Driveway Access Signs](#).

f. Location.

- (1) Driveway access signs are allowed in the B-2, M-1, and M-2 Districts.
- (2) Driveway access signs may be placed on an off-site zoning lot that is a maximum of 1,250 feet from a driveway in accordance with [Section 12.02.D.2 \(Private Property\)](#).

g. Quantity.

- (1) Two on-site driveway access signs are allowed per driveway accessed from a public street.
- (2) One off-site driveway access signs is allowed per driveway accessed from a public street.
- (3) One driveway access sign is allowed per intersection of internal driveways.

h. Size.

- (1) On-site driveway access signs must not exceed four square feet in area and four feet in height per sign.
- (2) Off-site driveway access signs must not exceed 32 square feet in area and six feet in height per sign.

i. Illumination. Illumination of driveway access signs is prohibited.

Figure 12.05.6 Driveway Access Signs

On-Site Driveway Access Sign

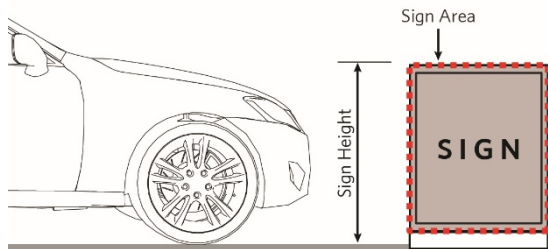

Off-Site Driveway Access Sign

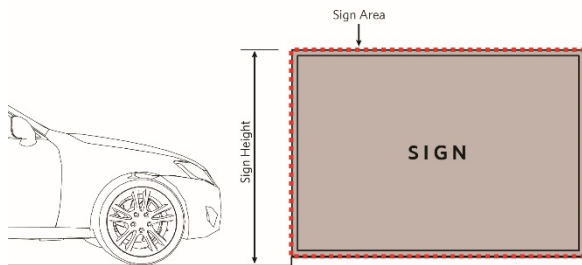

6. Electronic Message Signs. Refer to [Figure 12.05.7 Electronic Message Signs.](#)

a. Location.

- (1) Electronic message signs are allowed in the B-2 District and in all districts for parks, schools, libraries, government facilities, places of worship, or similar uses as determined by the Zoning Officer.
- (2) Electronic message signs are allowed as components of marquee signs or the lower portion of monument signs. An electronic message sign is subject to the regulations pertaining to the sign type upon which it is located.

b. Quantity. One electronic message sign is allowed per zoning lot.

c. Size. An electronic message sign must not occupy more than 30 percent of the total sign area of the marquee or monument sign on which it is displayed.

d. Illumination.

- (1) Internally illuminated electronic message signs are allowed only in accordance with section [Section 12.02.E \(Illumination\).](#)
- (2) Electronic message signs are allowed to change their message once every 5 seconds, and the transitions between messages must be instantaneous.
- (3) Electronic message signs must display static messages that do not contain a light source that flashes, blinks, strobes, travels, chases, rotates, or changes in intensity, brightness, or color.
- (4) Electronic message signs must be designed to default to a static display in the event of mechanical failure.

Figure 12.05.7 Electronic Message Signs

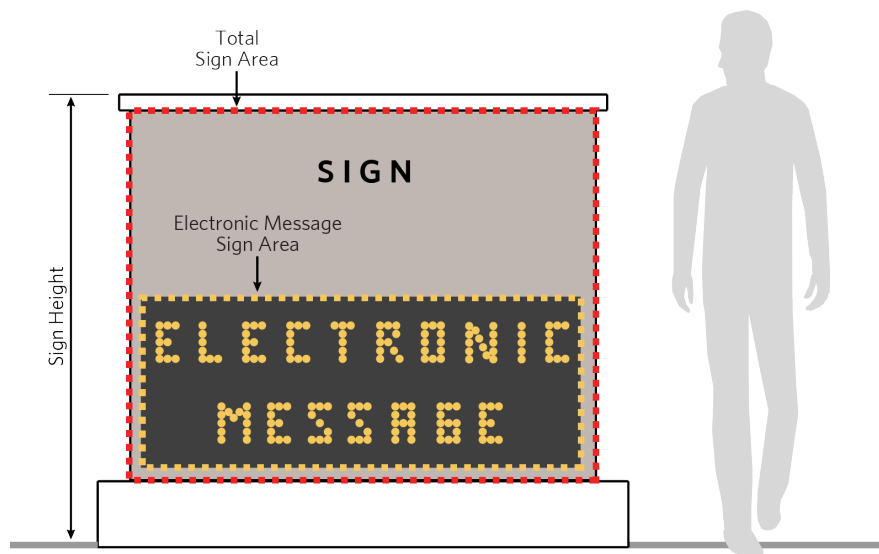

7. Manually Changeable Copy Signs. Refer to [Figure 12.05.8. Manually Changeable Copy Signs.](#)
- a. Location.
 - (1) Manually changeable copy signs are allowed in the MD, B-1, B-2, M-1, M-2 Districts, and in all residential districts for non-residential uses.
 - (2) Manually changeable copy signs are allowed as components of marquee or monument signs. A manually changeable copy sign is subject to the regulations pertaining to the sign type upon which it is located.
 - b. Quantity. One manually changeable copy sign is allowed per zoning lot.
 - c. Size. A manually changeable copy sign must not occupy more than 30 percent of the total sign area of the marquee, monument, or wall sign on which it is displayed.
 - d. Illumination. Internally illuminated manually changeable copy signs are allowed only in accordance with [Section 12.02.E \(Illumination\).](#)

Figure 12.05.8 Manually Changeable Copy Signs

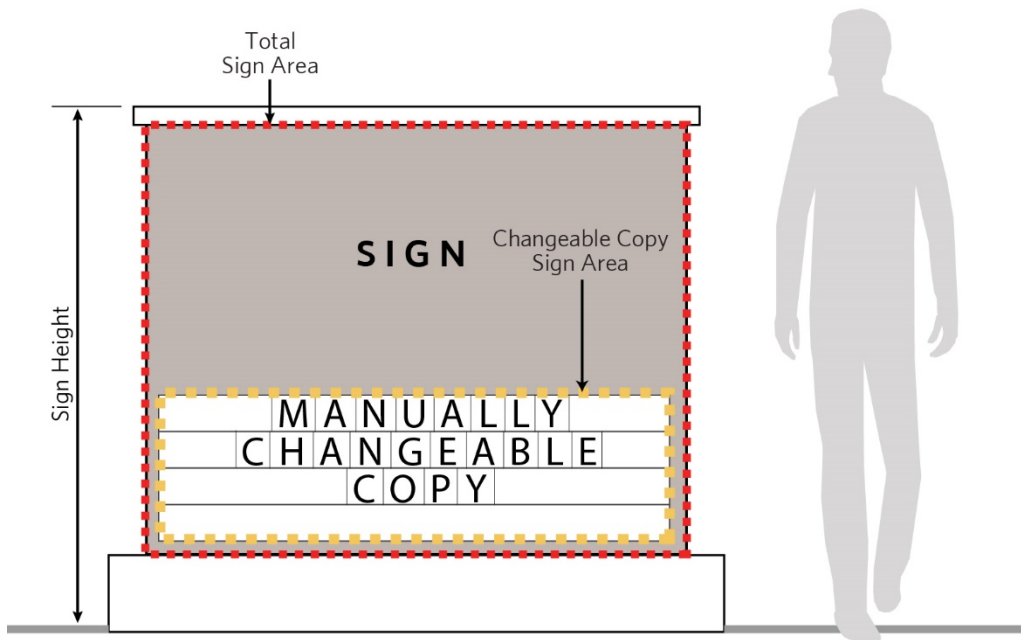

8. Marquee Signs. Refer to [Figure 12.05.9. Marquee Signs.](#)
- e. Location.
 - (1) Marquee signs are allowed in the MD, B-1, and B-2 Districts.
 - (2) A marquee sign may project from the front or corner side façade of the building to which it is attached, but must not project beyond the curb line.
 - (3) A marquee sign must be located a minimum of one foot from the edges of the façade to which it is attached, except for marquee signs that wrap around a building corner.
 - (4) Marquee signs must be located at least eight feet above grade.
 - f. Quantity. One marquee sign is allowed per frontage containing a primary tenant entrance.
 - g. Size. Marquee signs must not exceed three square feet of sign area per one linear foot of building frontage, including any individual letters, logos, and/or representation mounted on top of the roof of the marquee.
 - h. Components. An electronic message sign or manually changeable copy sign is allowed as a component of a marquee sign, in accordance with [Section 12.05.B.6 \(Electronic Message Signs\)](#) and [Section 12.05.B.7 \(Manually Changeable Copy Signs\)](#).
 - i. Illumination. Internally illuminated marquee signs are allowed in accordance with [Section 12.02.E \(Illumination\)](#).
 - j. Display Standards. A marquee sign must be supported solely by the building to which it is attached, and cannot be supported by ground-mounted columns or posts.

Figure 12.05.9 Marquee Signs

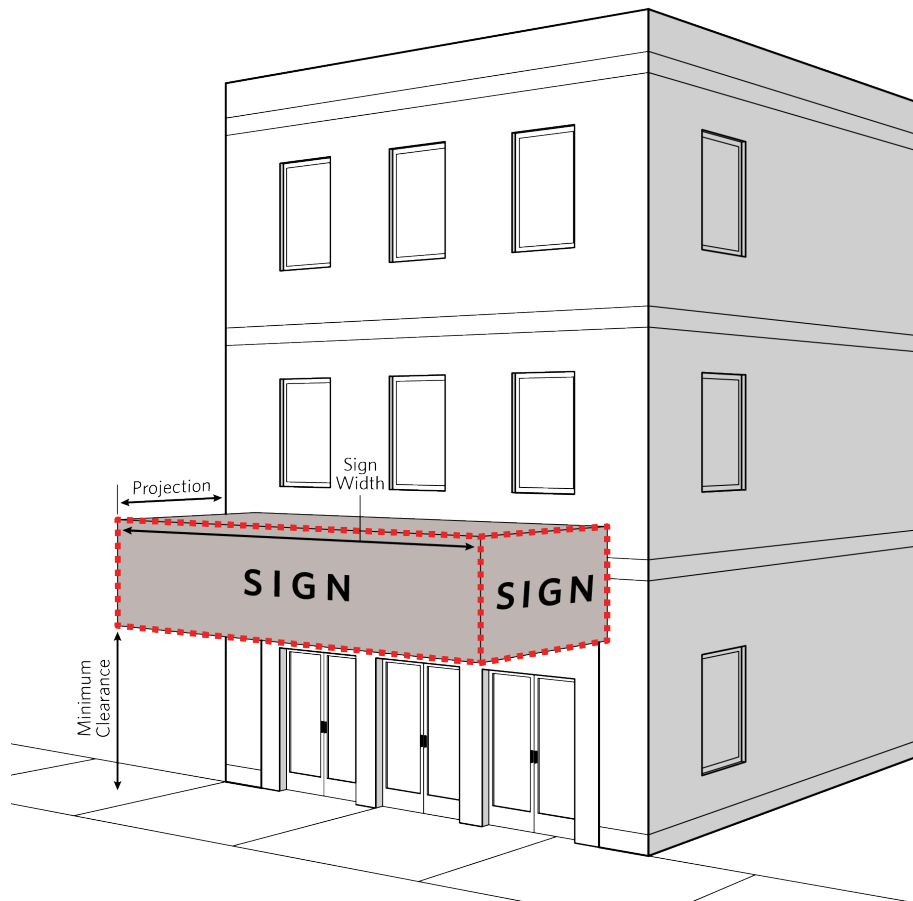

9. Monument Signs. Refer to [Figure 12.05.10. Monument Signs.](#)
- a. Location.
 - (1) Monument signs are allowed in the A, MD, B-1, B-2, M-1, M-2 Districts, and in all residential districts for residential development identification and non-residential uses.
 - (2) Monument signs must be located a minimum of five feet from any lot line.
 - b. Quantity.
 - (3) One monument sign is allowed per street frontage on a zoning lot except in residential subdivisions where one monument sign is allowed for every 500 linear feet of the subdivision.
 - c. Size.
 - (4) In residential districts, monument signs must not exceed 80 square feet in area per sign and 8 feet in height.
 - (5) In non-residential districts, multi-tenant monument signs for developments with five tenants or more in two or more buildings must not exceed 240 square feet in area per sign and 20 feet in height. In non-residential districts, multi-tenant monument signs for developments with two tenants or more in one building must not exceed 140 square feet in area per sign and 14 feet in height. In non-residential districts, single-tenant monument signs must not exceed 80 square feet in area per sign and 8 feet in height.
 - (6) If grade at the sign location is below the grade of the adjacent street, then grade at the sign location may be elevated to the same height as the grade of the adjacent street.
 - d. Components. An electronic message sign or manually changeable copy sign is allowed as a component of a monument sign, in accordance with [12.05.B.6 \(Electronic Message Signs\)](#) and [Section 12.05.B.7 \(Manually Changeable Copy Signs\).](#)
 - e. Illumination. Internally and externally illuminated monument signs are allowed only in accordance with [Section 12.02.E \(Illumination\).](#)
 - f. Landscape. The area surrounding the base of all monument signs must be landscaped. The landscape area must extend a minimum of three feet in width on all sides of the sign base and consist of shrubs, perennials, and/or other vegetative groundcover. A landscape plan must be submitted as part of any sign permit application (see [Section 4.09 \(Sign Permit\)](#)), and approved by the Zoning Officer. The Zoning Officer may approve alternative landscape designs when soil conditions, space constraints, or other factors beyond reasonable control of the applicant preclude the applicant from meeting the requirements set forth in this Section.
 - g. Materials. Monument signs must have a continuous base and must be constructed of masonry, finished split face block, stone, hardwood, polymer material with a wood appearance, metal, or other sturdy material that matches or complements the face of the sign. If the primary building on-site uses decorative masonry, the sign base should use the same material.

Figure 12.05.10 Monument Signs

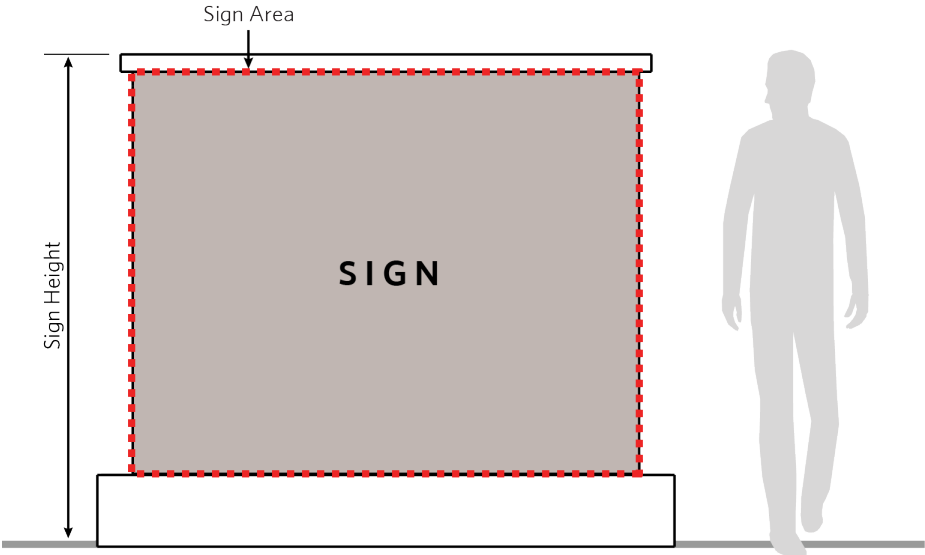

10. Projecting Signs. Refer to [Figure 12.05.11 Projecting Signs](#).

a. Location.

(7) Projecting signs are allowed in the MD, B-1, and B-2 Districts.

(8) A projecting sign must not project more than six feet from the face of the building to which it is attached, including the area between the sign and the face of the building. Projecting signs must be at least two feet from the curb of a street or the edge of a driveway.

(9) Projecting signs must be located at least seven feet above grade. Projecting signs must not be located more than 14 feet above grade.

(10) A projecting sign must not project above the roof of the building to which the sign is attached. All structural supports must be attached to the façade of the building, and must not be attached to the roof.

b. Quantity. One projecting sign is allowed per street frontage per tenant located on the ground floor. Projecting signs are allowed on façades that do not display wall signs.

c. Size. Projecting signs must not exceed 12 square feet in area per sign.

d. Illumination. Internally illuminated projecting signs are allowed in the B-2 District and externally illuminated projecting signs are allowed in the MD and B-1 Districts only in accordance with [Section 12.02.E \(Illumination\)](#).

e. Material. Projecting signs must be constructed of wood, wood composite, or metal.

Figure 12.05.11 Projecting Signs

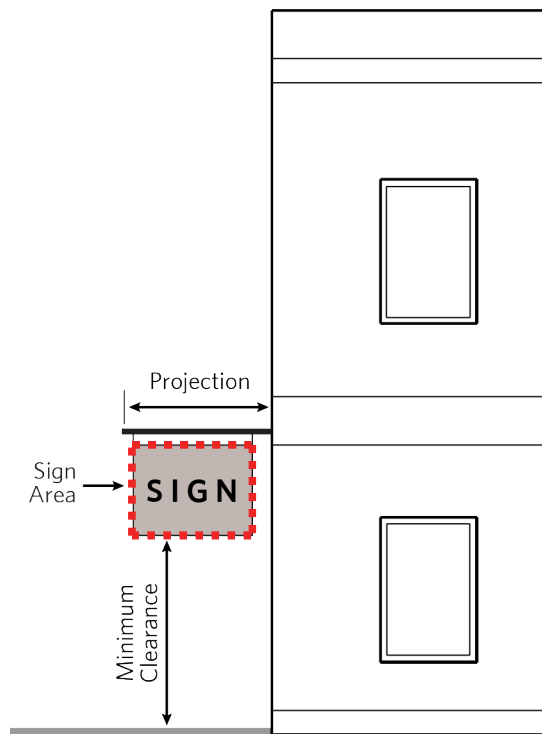

Side View

11. Wall Signs. Refer to [Figure 12.05.12 Wall Signs](#).
 - a. Location.
 - (11) Wall signs are allowed in the MD, B-1, B-2, M-1, M-2 Districts, and in all residential districts for non-residential uses and multiple-unit dwelling uses.
 - (12) Wall signs must be installed on the building façade and must not project more than 18 inches from the face of the building.
 - (13) Wall signs must be located at a generally uniform height throughout multi-tenant commercial developments.
 - (14) A wall sign must not project above the top of the wall to which it is attached.
 - b. Quantity.
 - (15) One wall sign is allowed per street frontage per tenant with an exterior building entrance.
 - (16) One additional wall sign is allowed per tenant on the side or rear façade of the building if the tenant has frontage on a corner side lot line, interior side lot line, or rear lot line.
 - c. Size.
 - (17) The total area of wall signs on the front or corner side façade must not exceed one square foot of sign area per linear foot of the building façade to which the sign will be affixed, as measured along the front or corner side façade, or 40 square feet, whichever is greater.
 - (18) The total area of wall signs on the rear or interior side façade must not exceed one-half square foot of sign area per linear foot of the building façade to which the sign will be affixed.
 - (19) The allowable wall sign area measured for any façade must only be applicable for use on that façade, and is not transferable to other façades.
 - (20) The height of a wall sign must not exceed 10 feet.
 - d. Illumination. Internally and externally illuminated wall signs are allowed only in accordance with [Section 12.02.E \(Illumination\)](#).
 - e. Painted Wall Signs. Painted wall signs displaying a business name, products, or services may be displayed on building façades facing a corner side, interior side, or rear yard, if such signs are professionally painted.

Figure 12.05.12 Wall Signs

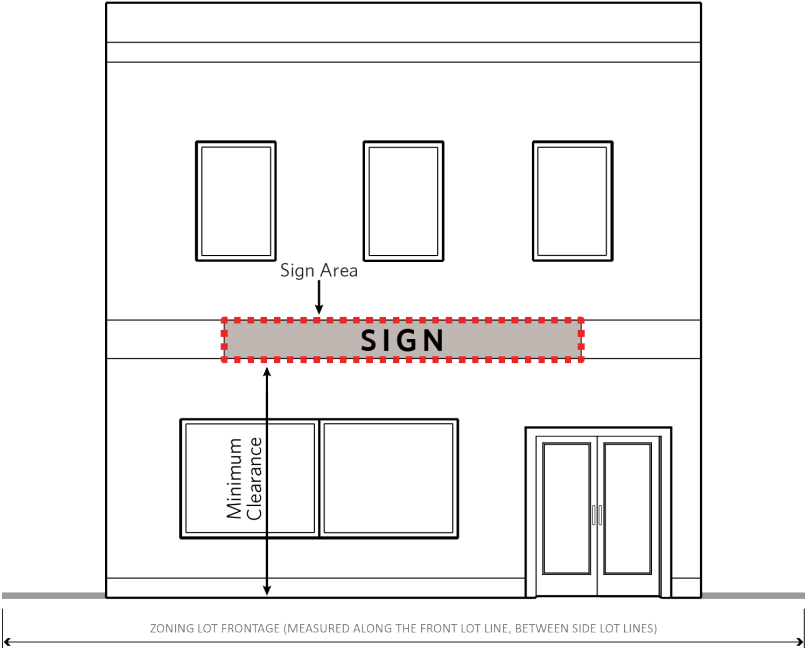

12. Window Signs. Refer to [Figure 12.05.13 Window Signs](#).
- a. Location. Window signs are allowed in the MD, B-1, B-2, M-1, M-2 Districts, and in all residential districts for non-residential uses and multiple-unit dwelling uses, for establishments facing a public street or on a public entrance.
 - b. Size. Window signs must not occupy more than 50 percent of the total ground floor window area of each building façade. Window signs located in stories above the ground floor must not occupy more than 50 percent of the total window area of that story on each building façade.
 - c. Illumination. Internally illuminated window signs, including neon signs, are allowed only in accordance with [Section 12.02.E \(Illumination\)](#). One neon sign is allowed for uses in the MD, B-1, and B-2 Districts and must not exceed 10 square feet in area.

Figure 12.05.13 Window Signs

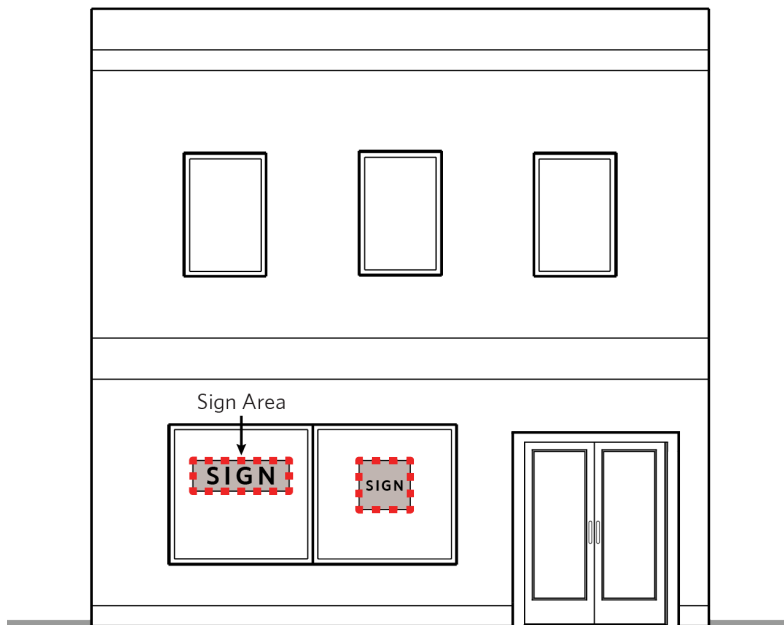

12.06 Temporary Signs

Temporary signs are allowed in accordance with the provisions of this Section, except where other sections of this Section regulate such signs, the more restrictive regulation applies.

A. General Provision. All temporary signs must comply with the following standards.

1. Illumination. Temporary signs must not be illuminated.
2. Relation to Products or Services. Temporary commercial signs must be related to the products or services sold on the premises. This regulation does not apply to temporary residential signs.
3. Location. Temporary signs must be located a minimum of one foot from any lot line unless otherwise noted in this Section.

B. Temporary Signs Allowed Without Sign Permit. The following types of temporary signs are allowed without a sign permit and must comply with the following standards.

1. Temporary Window Signs.

- a. Location. Temporary window signs are allowed in all zoning districts on the ground floor.
- b. Size. Temporary window signs must not occupy more than 50 percent of the total ground floor window area on each building façade.
- c. Display Period. Temporary window signs are limited to a display period of four weeks per calendar year.

2. Vehicle for Sale Signs.

- a. Location. Vehicle for sale signs are allowed in the B-1 and B-2 Districts for motor vehicle sales uses on vehicles that are parked legally.
- b. Quantity. One vehicle for sale sign is allowed per vehicle.

3. Yard Signs.

- a. Location. Yard signs are allowed in all zoning districts.
- b. Quantity. Two yard signs are allowed per street frontage. Additionally, one yard sign is allowed per street frontage for each of the following qualifying conditions, limited to the display period and maximum sign area listed for each in this Section:
 - (1) The applicant has an active, approved building permit for activities on the property on which the sign is located. Such yard sign must be removed no later than 10 days after expiration of the building permit, or issuance of an occupancy permit, whichever occurs first.
 - (2) The applicant is conducting a garage or yard sale on the property on which the sign is located. Such yard sign may be installed two days prior to the garage or yard sale and must be removed on the final day of the garage or yard sale.
 - (3) The subject property, or buildings therein, are currently for sale, lease, or rent. Such yard sign must be removed no later than one day after the sale, rental, or lease agreement signing for the subject property.
 - (4) This Ordinance does not limit the number of yard signs allowed prior to or following an election, but the display of such signs is limited by the aggregate area of all yard signs in accordance with [Section 12.06.B.3.c \(Size\)](#).

c. Size.

- (1) In residential districts, individual yard signs must not exceed six square feet in area per sign and six feet in height. In residential districts, the aggregate area of all yard signs must not exceed 18 square feet.
- (2) In non-residential districts, individual yard signs must not exceed 20 square feet in area per sign and eight feet in height. In non-residential districts, the aggregate area of all yard signs must not exceed 40 square feet.

C. Temporary Signs with Permit Requirement. The following temporary signs require a Temporary Sign Permit, per [Section 4.09 \(Sign Permit\)](#), and must comply with the following standards.

1. Banner Signs and Banner Flag Sign.

a. Location.

(1) Banner signs and banner flag signs are allowed for non-residential uses in all zoning districts. Uses that have an electronic message sign or a manually changeable copy sign must not have a banner sign or a banner flag sign.

(2) Banner signs must not project above the roof of the building to which it is attached.

b. Quantity. One banner sign or banner flag sign is allowed per business. A banner sign may be displayed as a monument sign, wall sign, window sign, or staked to the ground.

c. Size. Banner signs must not exceed 40 square feet in area. Banner flags must not exceed 10 feet in height.

d. Display Period. Banner signs and banner flag signs are limited to a display period of 15 days per sign permit period. A maximum of 12 banner sign or banner flag sign permits are allowed per year. Banner sign and banner flag sign permits may run consecutively.

2. Developer-Erected Signs.

a. Location.

(1) Developer-erected signs must be located a minimum of five feet from any lot line.

(2) A developer-erected sign must be located a minimum of one-quarter mile from another developer-erected sign.

(3) Developer-erected signs must be located a minimum of 100 feet from an existing residential dwelling unit.

b. Quantity. One developer-erected sign is allowed per entrance to the development.

c. Size. Developer erected signs must not exceed 120 square feet in area and 15 feet in height.

d. Display Period.

(1) In residential zoning districts, developer-erected signs are limited to a display period of 12 months.

(2) In non-residential zoning districts, developer-erected signs are limited to a display period of six months.

(3) In both residential and non-residential zoning districts, the applicant may extend the expiration date of a developer-erected sign by means of a written request filed with the Zoning Officer at least 30 days prior to the expiration date.

e. Materials. The construction materials of a developer-erected sign will be approved by the Zoning Officer as part of sign permit approval.

12.07 Prohibited Signs

It is unlawful to erect the following prohibited signs or devices in any zoning district.

- A. Bench Signs.
- B. Flashing Signs.
- C. Inflatable Devices
- D. Moving Signs. No sign or other advertising device may have moving, revolving, or rotating parts. Moving signs does not include barber poles, electronic message signs, flags, inflatable devices, pennant signs, and signs displaying time and temperature, street clocks, and other signs as established by this Section.
- E. Obscene Signs.
- F. Off-Premises Signs.
- G. Pole Signs.
- H. Portable Sign.
- I. Signs that Interfere with Traffic. No sign or other advertising device may interfere with, obstruct the view of, or be confused with any traffic sign, signal, or device because of its position, shape, illumination, or color.
- J. Snipe Signs.
- K. Roof Signs.
- L. Vehicle Signs. Signs mounted on trailers or motor vehicles where the primary use is to display signage rather than the operation of personal or business transportation uses.
- M. Video Display Signs.

SECTION 13: DEFINITIONS

[13.01 Purpose](#)

[13.02 Definition of Terms](#)

13.01 Purpose

The purpose of this Section is to define the terms used throughout this Ordinance.

13.02 Definition of Terms

A-Frame Sign: A movable sign placed on the ground and constructed in the shape of an “A” or some variation thereof.

Accessibility Ramp: An inclined structure that allows increased access to a building or structure.

Accessory Dwelling Unit (ADU): A small, self-contained residential dwelling unit that is secondary to a larger residential dwelling unit located on the same lot.

Accessory Structure: A structure located on the same lot as a principal structure that is subordinate in structure and use to the principal structure.

Accessory Use: A use located on the same zoning lot as a principal use that is subordinate to the principal use.

Addition: Construction that increases the size of a building or structure in terms of height, length, depth, width, floor area, or impervious coverage.

Adjacent: Property or a right-of-way that touches a lot line of the subject property or is separated by a public alley. Properties are not be considered adjacent to one another if a street separates the properties.

Administrative Adjustment: Authorization granted by the Zoning Officer to allow development that deviates from the specific regulations of this Ordinance within a narrowly defined set of circumstances.

Adult Cabaret: An establishment that features any of the following: people who appear nude or seminude; live performances that are distinguished or characterized by an emphasis on the exposure, depiction, or description of “Specified Anatomical Areas” or the conduct or simulation of “Specified Sexual Activities”; or films, motion pictures, videos, slides, computer displays, or other visual representations or recordings that emphasize “Specified Anatomical Areas” or “Specified Sexual Activities.”

Adult Store: An establishment having a substantial or significant portion of its sales or stock in trade devoted to books, magazines, periodicals, other printed matter, instruments, novelties, devices, paraphernalia, films, motion pictures, videos, digital materials, or other visual representations that are distinguished or characterized by their emphasis on matter depicting, describing, or relating to “Specified Sexual Activities” or “Specified Anatomical Areas.” This includes any establishment with a

segment or section devoted to the sale or display of such materials, or an establishment that publicly claims itself as a purveyor of such materials based upon its signage, advertising, displays, actual sales, presence of booths, or any other factors showing the establishment's primary purpose is to purvey such material.

Adult Theater: An establishment that, as a substantial or significant portion of its business, presents films, motion pictures, videos, digital materials, or other visual representations that are distinguished or characterized by an emphasis on matter depicting, describing, or relating to "Specified Sexual Activities" or "Specified Anatomical Areas."

Adult Use: "Adult Use" includes "Adult Cabarets," "Adult Stores," "Adult Theaters," and other similar uses.

Agricultural Use: The use of land for farming, including, but not limited to animal husbandry, dairying, pasturage, horticulture, floriculture, viticulture, apiculture, aquaculture, hydroponics, tree farms, and sod farms, where these uses are the principal use of the land. Agriculture does not include "Garden Center."

Alley: A narrow right-of-way that provides a means of access to adjacent properties typically located at the side or rear of a lot.

Alteration: A change in the supporting members of a building or structure, such as bearing walls, partitions, columns, beams, or girders, or a substantial change to the roof or exterior walls.

Animal Boarding, Hospital, or Shelter: An establishment where pet animals are temporarily boarded, treated for illness or injury, and/or temporarily cared for while permanent homes are found for them.

Antenna: A linear antenna designed to send and/or receive television, radio, communication, data, or other similar signals from other antennas. "Antenna" does not include "Satellite Dish," "Wireless Telecommunication Antenna," or "Wireless Telecommunication Small Cell."

Arbor: A freestanding structure that serves to support climbing plants, often used to define an access point to a garden.

Assisted Living Facility: A residential facility that provides daily assistance and long-term residence for three or more disabled and/or elderly individuals, but does not provide regular in-patient medical or nursing care. Such facilities provide a combination of housing, supportive services, personalized assistance, and health care designed to respond to the individuals who need help with common daily activities, such as dressing, grooming, and bathing. An "Assisted Living Facility" does not include "Community Residence," "Independent Living Facility," or "Nursing Home."

Awning: A roof-like cover, often constructed of flexible fabric and/or metal, which projects from the wall of a structure over a window, sidewalk, or door and is designed for protection from the weather or as a decorative element.

Awning Sign: A sign that is displayed on an awning.

Balcony: A platform that projects from the exterior wall of a building, which is exposed to the open air, has direct access to the interior of a building, and is not supported by columns extending to the ground.

Banner Flag Sign: A sign typically made of lightweight fabric or other flexible material that is mounted to a pole and designed to move in the wind. Refer to [Figure 13.02.1 Banner Flag Sign](#).

Figure 13.02.1 Banner Flag Signs

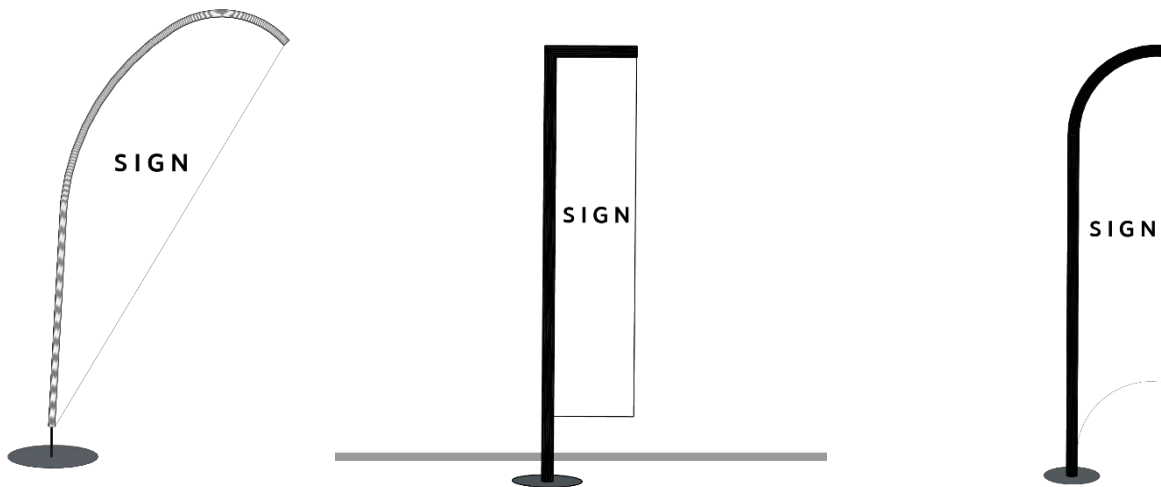

Banner Sign: A sign typically made of lightweight fabric or other flexible material with or without a frame. “

Basement: A portion of a building located underground. A basement is counted as a story for the purpose of measuring building height if more than half of its height is above grade.

Bay Window: A window built to project outward from an exterior wall, often with a flat front and angled sides.

Ball Court: A paved area used to play sports and/or games.

Banquet Hall: An establishment that provides accommodations for private functions, such as weddings, anniversaries, or other similar celebrations. Such use may include facilities for the preparation of food, sale of alcoholic beverages for on-premises consumption, and outdoor reception facilities.

Bar/Tavern: An establishment that sells alcoholic beverages for consumption on the premises, and may serve food for consumption on the premises in a manner that is incidental to the sale of alcoholic beverages.

Bee Colony: An enclosure used to house bees.

Bench Sign: A sign located on a bench, seat, or similar structure which directs attention to a business, product, or service.

Bicycle Lane: A portion of the roadway that has been designated for the use of bicyclists.

Bicycle Parking Sign: A sign indicating the location of bicycle parking facilities.

Bicycle Parking Space: An area used to park a bicycle that may or may not be located on a right-of-way.

Bioretention: The process of utilizing a shallow vegetated basin to collect and absorb stormwater runoff as part of systems such as bioretention cells, bioretention curb extensions, and bioretention planters.

Block: Land bounded on all sides by street rights-of-way, utility rights-of-way, and/or physical barriers such as bodies of water or public open spaces.

Blue Roof: A roof that is designed to store and discharge rainfall.

Body Art Establishment: An establishment that provides physical body adornment, alteration or modification that may include, but is not limited to, tattooing, piercing, branding, braiding, implantation, or scarification.

Building: A structure with substantial walls and a substantial roof that is securely affixed to land and separated on all sides from similar structures by space or by walls that do not have communicating doors, windows, or similar openings.

Building Height: The vertical distance measured from the mean average elevation of finished grade at the front building line to the highest point of a building. The following projections are not included when determining building height: chimneys, towers, spires, steeples, parapet walls, staircase enclosures, elevator enclosures, tanks, cooling towers, green roofs, blue roofs, mechanical equipment, and similar projections.

Building Line: A line measured at the building wall of a structure that is parallel or nearly parallel to a lot line. For the purposes of establishing a building line, the building wall does not include permitted encroachments of architectural features, such as bay windows, eaves, stairs, and stoops.

Buffer Yard: A yard or landscape component used to separate uses or structures, provide a visual barrier, diminish light trespass, or for other similar purposes.

Bulk: The size and shape of a building or structure as defined by its lot area, lot width, height, and proportion of impervious coverage.

Cabana: A portable or semi-permanent structure often used as a changing room for a swimming pool or other recreational use.

Candela: The base unit of measuring luminous intensity according to the International System of Units. A typical candle emits light with a luminous intensity of approximately one candela.

Cannabis Business: "Cannabis Business" includes "Cannabis Craft Grower," "Cannabis Cultivation Center," "Cannabis Dispensary," "Cannabis Infuser," "Cannabis Processor," or "Cannabis Transporter."

Cannabis Craft Grower: An establishment licensed, certified, or accredited by the appropriate local and state agencies that cultivates, dries, cures, packages, and/or performs activities to produce cannabis products to provide to “Cannabis Dispensaries” or “Cannabis Processors.”

Cannabis Cultivation Center: An establishment licensed, certified, or accredited by the appropriate local and state agencies that cultivates, processes, transports, and /or performs activities to produce cannabis products to provide to other “Cannabis Businesses.”

Cannabis Dispensary: A commercial establishment licensed, certified, or accredited by the appropriate local and state agencies that provides cannabis products, paraphernalia, and/or related supplies directly to the consumer for purchase and removal from the premises by the purchaser.

Cannabis Infuser: An establishment licensed, certified, or accredited by the appropriate local and state agencies that incorporates cannabis into products to provide to other “Cannabis Businesses.”

Cannabis Processor: An establishment licensed, certified, or accredited by the appropriate local and state agencies that produces cannabis concentrate or incorporates cannabis into products to provide to other “Cannabis Businesses.”

Cannabis Transporter: An establishment licensed, certified, or accredited by the appropriate local and state agencies that transports cannabis to provide to other “Cannabis Businesses” or licensed “College or University” under the Cannabis Vocational Training Program.

Canopy: A rigid roof-like cover, often constructed of metal and/or glass, which projects from the wall of a structure over a window, sidewalk, or door and is designed for protection from the weather or as a decorative element. A canopy may include ground-mounted support posts.

Canopy-Mounted Sign: A sign that is mounted on top of a canopy.

Car Wash: An establishment engaged in the cleaning or detailing of motor vehicles, recreational vehicles, and/or other similar vehicles whether automatic or by hand.

Cemetery: Land used for the burial of the deceased, which may include offices, structures for performing religious ceremonies related to the entombment of the deceased, and related accessory structures for the storage of maintenance equipment.

Chimney: A vertical structure used to remove smoke and combustion gases from a building that is often of masonry construction.

Club, Lodge, or Hall: A meeting, recreational, or social facility established for the use of the members and guests of a non-profit or private organization.

Cluster Subdivision Design: A subdivision process that allows for groupings of smaller lots that do not increase the overall density of lots within a development as compared to conventional subdivision layout. Cluster subdivision design is intended to promote environmentally sensitive development, preserve common open space, and achieve a balance between well-designed neighborhoods and natural resource protection.

College or University: A facility for post-secondary higher learning that grants associate or bachelor degrees. The institution may also have research facilities and/or professional schools that grant master and doctoral degrees. "College or University" includes ancillary uses such as dormitories, cafeterias, restaurants, retail sales, indoor or outdoor recreational facilities, and similar uses.

Commercial Vehicle: A motor vehicle operated for the transportation of people or material as part of a commercial enterprise.

Community Bee Colony: A bee colony that is collectively cultivated and maintained by a group of people.

Community Garden: Land that is collectively cultivated and maintained by a group of people.

Community Library Kiosk: A small, freestanding structure used for exchanging books and reference materials within a community.

Community Residence: A group residence consisting of a group home or specialized residential care home serving people with disabilities that is licensed, certified, or accredited by the appropriate state or federal agencies. Such residence serves as a single housekeeping unit for the housing of unrelated people with functional disabilities who share responsibilities, meals, social activities, and other aspects of residential living. A "Community Residence (Large)" provides living accommodations for nine or more residents while a "Community Residence (Small)" provides living accommodations for eight or fewer residents. "Community Residence" does not include "Assisted Living Facility," "Independent Living Facility," "Nursing Home," or "Residential Care Facility" and does not include "Transitional Treatment Facility, or a residence that serves as an alternative to incarceration for a criminal offense.

Compost Bin: A container used to store and break down organic matter to produce material that facilitates fertilizing and conditioning soil.

Comprehensive Plan: The comprehensive plan of the Village of Montgomery.

Conforming Structure: A structure that complies with the bulk and setback regulations of this Ordinance for the zoning district in which the structure is located.

Conforming Use: A use that complies with the use regulations of this Ordinance for the zoning district in which such use is located.

Conservation Subdivision Design: A subdivision process that requires a percentage of open space to be conserved while allowing for an increase in the density of lots in a development as compared to conventional subdivision design. Conservation subdivision design is intended to promote environmentally sensitive development, preserve common open space, and achieve a balance between well-designed neighborhoods and natural resource protection.

Construction Trailer: A portable building or structure that may include office space and/or facilities for equipment storage for a construction project.

Corner Lot: A parcel of land located at the intersection of two or more streets that has more than one street frontage, or a lot located at the bend of one street that has an interior angle no greater than 135 degrees. See [Figure 13.02.2 Lot Types](#).

Figure 13.02.2 Lot Types

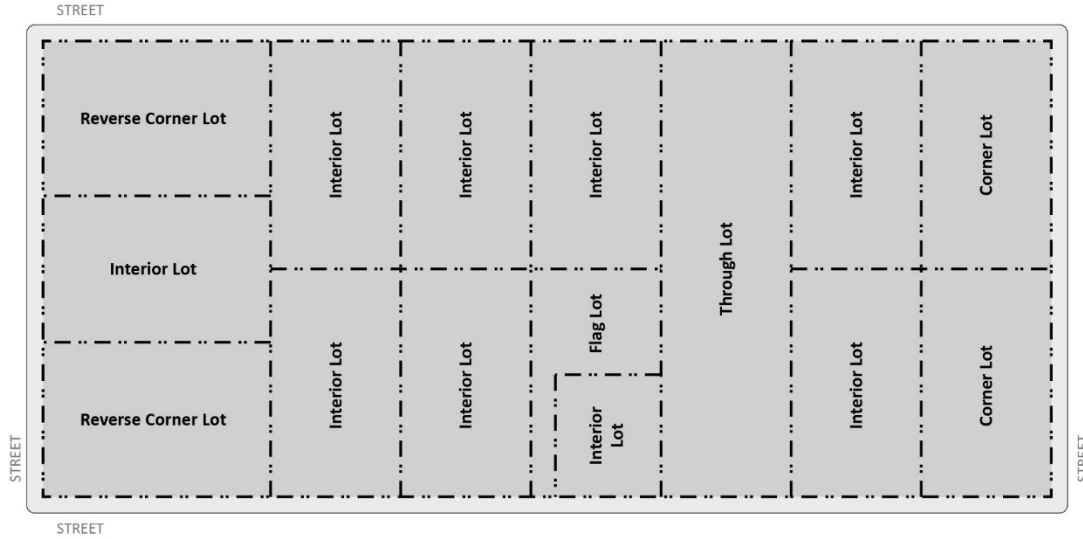

Corner Side Façade: Any façade that faces and is most closely parallel to the corner side lot line.

Corner Side Lot Line: The boundary of a lot that is approximately perpendicular to the front and rear lot lines, which separates the longest street right-of-way frontage of a corner lot from the street right-of-way. Refer to [Figure 13.02.3 Lot Lines and Yards](#).

Figure 13.02.3 Lot Lines and Yards

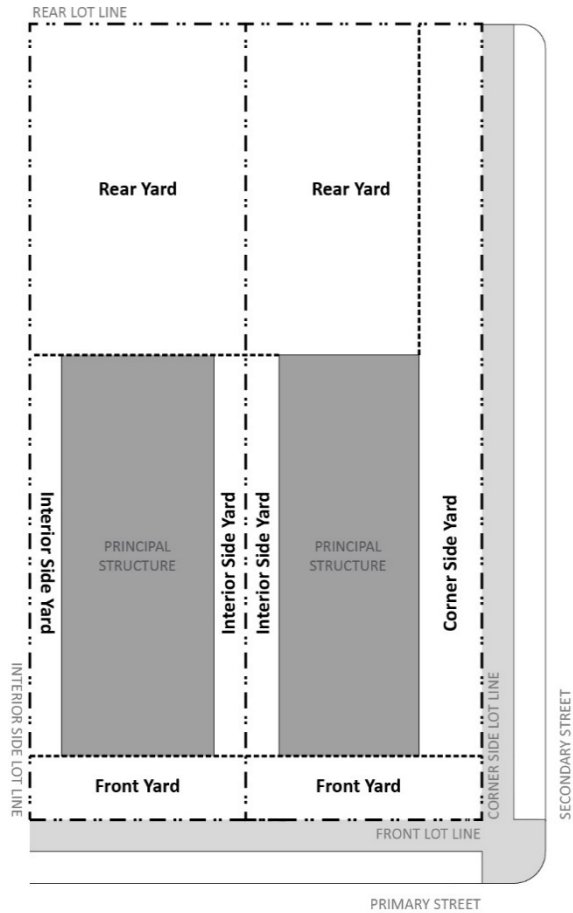

Corner Side Yard: The area on a lot extending from the corner side façade of a building to the corner side lot line between the front yard and the rear lot line. Refer to [Figure 13.02.3 Lot Lines and Yards](#).

Cornice: A projecting horizontal architectural feature, often located on the wall of a building or structure below the roofline.

Cross-Access: A vehicular and/or pedestrian connection between adjacent properties that allows circulation between the sites without using the sidewalk or street.

Cross Slope: The incline of a path perpendicular to the direction of travel.

Cultural Facility: A use that provides cultural services including, but not limited to, museums, cultural centers, historical societies, and libraries.

Currency Exchange: An establishment engaged in providing services to cash checks, issue money orders, and prepare cashier’s checks for a fee. “Currency Exchange” does not include “Financial Institution” or “Payday or Title Loan Establishment.”

Day Care Center: An establishment providing care for more than three adults or children in a protective setting for less than 24 hours per day that is not located within a residential dwelling unit. “Day Care Center” does not include day care programs operated by an “Elementary, Middle, or High School,” “Park,” or “Place of Worship.”

Day Care Home: A facility within a residential dwelling unit that provides care for adults or children, including the family’s children, in a protective setting for less than 24 hours per day.

Deck: A roofless outdoor platform often constructed of wood or composite wood that is elevated from the ground and connects to the exterior wall of a building.

Developer-Erected Sign: A temporary monument sign located at the entrance to a subdivision or similar unified improvement of land

Development: Any human-made change to improved or unimproved real estate, including, but not limited to construction of, or substantial improvements to, buildings or other structures.

Dog Run: An enclosed area located within a yard that provides space for a dog to exercise.

Drive-Through Facility: A facility used to provide products or services through a window, attendant, or automated machine to people in motor vehicles. A “Drive-Through Facility” may be established in combination with other uses, such as a “Financial Institution,” “Personal Services Establishment,” “Restaurant,” or “Retail Goods Establishment.” A “Drive-Through Facility” is not considered to be established in combination with a “Car Wash,” “Gas Station,” or “Motor Vehicle Repair and/or Service.”

Drive-Through Sign: A sign that is located adjacent to a drive through lane that accompanies an establishment with “Drive-Through Facilities.”

Driveway: An unobstructed area that provides access to a parking or loading space.

Driveway Access Sign: A sign that guides the circulation of motorists, bicyclists, and pedestrians to or through a site, such as signs indicating parking lot entrances and exits, loading zones, and restrooms.

Driveway Apron: The portion of a driveway that passes through the sidewalk, parkway, and curb into the adjacent street.

Driveway Parking Pad: A portion of a driveway used to park a motor vehicle that is generally wider than the portion of the driveway used to access the lot.

Dwelling Above the Ground Floor: A dwelling unit located on the upper floor of a building that contains non-residential uses on its ground floor.

Dwelling Unit: A structure, or portion thereof, designed for residential purposes as a single housekeeping unit that provides independent living facilities for one or more people, including permanent provisions for living, sleeping, eating, cooking, and sanitation. “Dwelling Unit” does not include “Hotel/Motel,” “Model Unit,” “Recreational Vehicle,” or tent.

Easement: Land that has been designated by lawful agreement between the owner of the land and another entity for a specified use by such entity.

Eave: The projecting lower edge of a roof that overhangs the wall of a building.

Electrical Generator: A device that generates electrical power.

Electric Vehicle Charging Station: A location used to supply energy to electric vehicles.

Electronic Message Sign: A sign that displays a changeable message with text, or simple images using an electronic display. "Electronic Message Signs" does not include "Video Display Signs."

Elementary, Middle, or High School: A public or private educational facility offering instruction to preschool, elementary school, middle school, junior high school, and/or high school students with a full range of curricular programs.

Encroachment: The location of a structure within a required setback.

Entry Door Sign: A sign that appears on or adjacent to entry doors or in display windows, which may display information such as hours of operation, credit cards accepted, open/closed signs, and push/pull signs.

Environmental Performance Standards: Criteria established to regulate noise, odor, dust, air pollution, glare, heat, vibration, fire, explosion hazards, or hazardous materials generated by the use of land or buildings.

Externally Illuminated Sign: A sign that is lit by a source of light located outside the sign so that light shines onto the sign face.

Façade: The exterior face of a building, including, but not limited to, the walls, windows, windowsills, doorways, and design elements.

Fence: A barrier typically constructed of treated wood, simulated wood, PVC, steel, or a combination of materials, that is erected to separate, screen, or enclose an area.

Farmers Market: An outdoor market located in a designated area for the sale of agricultural products, such as fruits, vegetables, juices, flowers, plants, herbs, spices, dairy goods, and meats, by the vendors who typically produce such items. "Farmers Markets" typically offer for sale items such as baked goods, arts and crafts, and other value-added goods.

Fill: Soil or other solid material that has been added to a portion of the ground surface.

Financial Institution: A bank, credit union, or savings and loan office, or an automated teller machine established by such an entity. "Financial Institution" does not include "Currency Exchange" or "Payday or Title Loan Establishment."

Finished Grade: The final elevation and contour of the ground surface after cut or fill has been added.

Flag: A sign made of flexible material which is mounted on a pole and symbolizes any governmental, political, civic, educational, religious, or corporate organization.

Flag Lot: A lot where the vast majority of the lot can only be accessed from the right-of-way by means of a narrow strip of land between adjacent lots. See [Figure 13.02.2 Lot Types](#).

Flagpole: A ground-mounted or building-mounted structure used to display a flag.

Flashing Sign: A sign which contains an intermittent or sequential light source that may flash, blink, strobe, travel, chase, rotate, or change in intensity, brightness, or color. "Flashing Signs" do not include "Electronic Message Signs," or "Video Display Signs."

Flat Roof: A flat roof structure with no visible slope, which is located on all street-facing façades and may or may not have overhanging eaves.

Foot-Candle: A measure of the illuminance cast upon a surface that is one foot from a uniform light source of one candela, and which is equal to one lumen per square foot.

Front Façade: Any façade that faces and is most closely parallel to the front lot line.

Front Lot Line: The boundary of a lot that is adjacent to a street right-of-way. For corner lots, the front lot line is the shortest street frontage of the lot. For irregular lots, the front lot line is the entire length of the lot line that is adjacent to a street right-of-way. Refer to [Figure 13.02.3 Lot Lines and Yards](#).

Front Yard: The area on a lot extending from the front façade of a building to the front lot line between the side lot lines. Refer to [Figure 13.02.3 Lot Lines and Yards](#).

Fully Shielded Lighting: A fixture that prevents light from being emitted above a horizontal plane running from the lowest point of the fixture that emits light.

Funeral Home/Crematory: An establishment where services are conducted for the deceased, including facilities to prepare the deceased for display, burial, and/or cremation.

Garage: A building, either attached or detached, which is used or designed for the parking and storage of motor vehicles, and the storage of various equipment.

Garage or Yard Sale: The sale of a variety of used household items, which is typically held in the garage or front yard of a residential dwelling unit.

Garden: An area dedicated to the cultivation of plants.

Garden Center: An establishment that sells plants grown or stored on site.

Gas Station: An establishment where motor vehicle fuel, including non-petroleum fuel, is stored and dispensed from fixed equipment into motor vehicles. A "Gas Station" may also include accessory activities such as restaurants, car washes, and convenience retail stores. "Gas Station" does not include "Motor Vehicle Repair and/or Service."

Gazebo: A freestanding open-sided structure, often hexagonal or octagonal in shape, that provides shade and shelter in outdoor areas.

Golf Course: A tract of land designed with at least nine holes for playing a game of golf and improved with tees, greens, fairways, and hazards. A golf course may include a clubhouse, driving range, restrooms, and related accessory structures for the storage of maintenance equipment.

Government Facility: A building or structure owned, operated, and/or occupied by a governmental agency to provide services to the public. "Government Facility" includes public safety facilities, public works facilities, post offices, and administrative offices, but does not include "Park," "Elementary, Middle, or High School."

Government Sign: A sign, such as a traffic control sign, public safety sign, emergency sign, or public notice that is erected by a governmental body or under the direction of such body.

Grade: The level of the finished surface of the ground adjacent to the exterior wall of a building or structure.

Grading: Altering the shape of the ground surface to a predetermined condition, which may include stripping, cutting, filling, stockpiling, and shaping or any combination of these practices.

Greenhouse: A building for the cultivation and protection of plants, which is typically constructed of transparent glass, metal, and/or plastic.

Green Roof: A roof that is partially or completely covered with vegetation, a growing medium, and a waterproof membrane, that absorbs rainwater and reduces the heat absorbed by a building or structure.

Gross Floor Area: The total horizontal area of the floors of a building as measured from the exterior face of the exterior walls, or from the centerline of a party wall to the exterior face of the exterior walls.

Gutter: A structure used to convey stormwater that is located at the eave of a roof.

Half Story: The portion of a building located under a pitched roof.

Hanging Sign: A sign suspended from an architectural feature of a building, such as an awning, canopy, or marquee, which is typically oriented perpendicular to the façade of the building.

Headstone: A non-commercial sign in the form of a tombstone, tablet, grave marker, statuary, or memorial, that offers a remembrance of people or events.

Heavy Manufacturing: A use engaged in manufacturing, assembly, fabrication, packaging, storage, handling, or other industrial processing of products from unprocessed or raw materials, which may include the use of highly flammable material, or toxic matter. "Heavy Manufacturing" uses may be engaged in processes that are likely to have a substantial impact on the environment or on adjacent properties. Typical "Heavy Manufacturing" uses include, but are not limited to, chemical processing, grain milling, metal casting, metal smelting, motor vehicle assembly, motor vehicle wrecking, petroleum

refining, rendering, tire assembly, and asphalt, brick, concrete, or tile manufacturing. “Heavy Manufacturing” does not include “Cannabis Cultivation or Processing Center.”

Historical Marker: A sign displaying information of historic significance such as a building’s name, date of erection, or location.

Home-Based Business: An occupation carried on in a dwelling unit by a resident, which is accessory to the residential use of the dwelling unit.

Hoophouse: A structure used to extend the growing season of agricultural crops that is generally made of plastic and semicircular in shape.

Hospital: An institution that provides healthcare and medical services for the sick and injured, which may include, but are not limited to, in-patient facilities, out-patient facilities, training facilities, offices, and laboratories.

Hot Tub: An in-ground or aboveground basin of water that includes an air-injection system and/or water heating system that is intended for soaking.

Hotel/Motel: An establishment that provides sleeping accommodations and lodging services on a short-term basis for a fee and amenities which may include, but are not limited to, restaurants, meeting rooms, health clubs, and swimming pools.

Illegal Structure: A structure that did not legally exist prior to the adoption of this ordinance and does not conform with the current ordinance requirements for the district in which it is located.

Illegal Use: An activity or facility that does not enjoy a legal conforming or legal nonconforming status, as defined in this ordinance.

Impervious Coverage: The proportion of the area of a zoning lot occupied by surfaces that do not allow stormwater infiltration to the lot area of the zoning lot. Surfaces that do not allow stormwater infiltration may include, but are not limited to, principal structures, accessory structures, walkways, paved parking lots, and paved driveways.

Improved Surface: An area that is covered by a permanent hard surface, such as concrete or asphalt, designed to support the weight of the items placed on top of the surface.

Independent Living Facility: A residential facility that contains dwelling units where at least one of the residents occupying a unit is 55 years or older. Such facilities do not provide regular in-patient medical or nursing care but may provide common areas for meals or socializing and limited convenience services. An “Independent Living Facility” does not include “Assisted Living Facility,” “Community Residence,” or “Nursing Home.”

Indoor Entertainment: An enclosed building where spectator uses are conducted by a for-profit entity that typically charges patrons a fee to enter. Typical “Indoor Entertainment” uses include, but are not limited to, indoor theaters, indoor music venues, and indoor sports arenas. “Indoor Entertainment” uses may include refreshment stands that provide products for consumption on the premises. “Indoor Entertainment” does not include “Adult Use” or “Indoor Recreation.”

Indoor Recreation: An enclosed building where recreational activities are conducted by a for-profit entity that typically charges patrons a fee to enter. Typical “Indoor Recreation” uses may include, but are not limited to, health clubs, bowling alleys, pool halls, children’s play facilities, sporting or training facilities, arcades, indoor miniature golf courses, indoor swimming pools, indoor tennis courts, and indoor skating facilities. “Indoor Recreation” uses may include refreshment stands that provide products for consumption on the premises. “Indoor Recreation” does not include “Indoor Entertainment,” “Park,” or “Elementary, Middle, or High School.”

Inflatable Device: An advertising display that consists of flexible fabric or similar material that can be filled with air or gas and that may or may not be tethered to a specific location, and may move using a fan.

Interior Lot: A parcel of land that has street frontage along at least one lot line and is flanked by lots along its side lot lines. See [Figure 13.02.2 Lot Types](#).

Interior Side Façade: Any façade that faces and is most closely parallel to the interior side lot line.

Interior Side Lot Line: The boundary of a lot that is approximately perpendicular to the front and rear lot lines and is not adjacent to the street right-of-way. Refer to [Figure 13.02.3 Lot Lines and Yards](#).

Interior Side Yard: The area on a lot extending from the interior side façade of a building to the interior side lot line between the front yard and the rear yard. Refer to [Figure 13.02.3 Lot Lines and Yards](#).

Internally Illuminated Sign: A sign that is lit by a source of light located inside the sign so that light shines outward from within the sign.

Irregular Lot: A lot whose opposing lot lines are generally not parallel, such as a pie-shaped lot, or where one or more lot lines are curvilinear.

Landscaped Setback: A planted area used to improve the safety, appearance and environment of major transportation arterials and collector streets.

Laundromat: An establishment that provides washing, drying, and/or ironing machines for use by customers on the premises.

Light Manufacturing: A use engaged in manufacturing, assembly, fabrication, packaging, storage, handling, or other industrial processing of products primarily from prepared materials or finished products, which does not include the use of highly flammable material, or toxic matter. “Light Manufacturing” uses may be engaged in processes that have a minimal impact on the environment and adjacent properties. Typical “Light Manufacturing” uses include, but are not limited to contractors, equipment suppliers, and commercial printing. “Light Manufacturing” does not include “Cannabis Cultivation or Processing Center.”

Live/Work Dwelling: A dwelling unit that has both residential and commercial components.

Loading Space: An unobstructed area provided and maintained for the temporary parking of motor vehicles in order to load and unload materials.

Long-Term Bicycle Parking: Bicycle parking intended for long-term or overnight storage, typically provided for employees, residents, or others requiring storage of a bicycle for a substantial portion of the day.

Lot: A parcel or tract of land intended to be separately owned, developed, or otherwise used.

Lot Area: The area of a zoning lot contained within its lot lines.

Lot Depth: The mean distance between the front and rear lot lines of a lot.

Lot Line: The boundary line of any lot.

Lot of Record: A legally created lot established by plat, deed, or contract, as recorded by the Kane or Kendall County Recorder of Deeds.

Lot Width: The minimum horizontal distance between the side lot lines of a lot measured at the narrowest width within the buildable area. See [Figure 13.02.4 Lot Width](#).

Figure 13.02.4 Lot Width

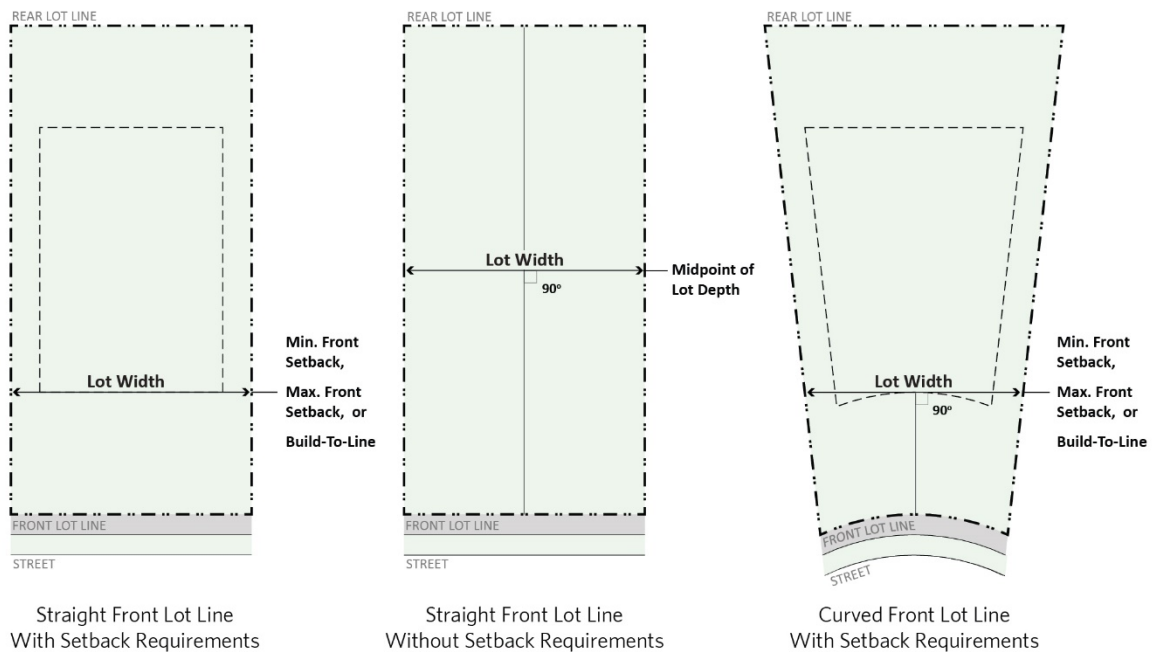

Machinery and Equipment Sales and Rental: Establishments primarily engaged in the sale or rental of tools, trucks, tractors, construction equipment, and similar industrial equipment. “Machinery and Equipment Sales and Rental” includes the incidental storage, maintenance, and servicing of such equipment.

Manually Changeable Copy Sign: A sign designed to allow modifications of messages, letters, characters, illustrations, or other symbols by hand. “Manually Changeable Copy Signs” do not include “Electronic Message Signs.”

Marquee Sign: A sign with two or three sign faces that is mounted to a permanent roof-like structure extending from the façade of a building.

Maximum Corner Side Setback: The maximum distance that a building or structure is located from a corner side lot line, as required by the zoning district regulations.

Maximum Front Setback: The maximum distance that a building or structure is located from a front lot line, as required by the zoning district regulations.

Mechanical Equipment: Ground-mounted and roof-mounted equipment such as heating, ventilating, and air-conditioning (HVAC) units.

Microbrewery or Microdistillery: A facility for the production and packaging of malt beverages of alcoholic content with a capacity of less than 30,000 barrels per year, or a facility for the production and packaging of spirits and liquors with a capacity of less than 50,000 gallons per year. Microbreweries or Microdistilleries include a tasting room, which allows customers to consume products manufactured on site, and/or a retail space for purchase of products manufactured on site and related items. Breweries that exceed a capacity of 30,000 barrels per year, distilleries that exceed a capacity of 50,000 gallons a year, or facilities that only manufacture for distribution are considered either “Light Manufacturing” or “Heavy Manufacturing” depending on capacity.

Minimum Corner Side Setback: The minimum distance that a building or structure is located from a corner side lot line, as required by the zoning district regulations.

Minimum Front Setback: The minimum distance that a building or structure is located from a front lot line, as required by the zoning district regulations.

Minimum Interior Side Setback: The minimum distance that a building or structure is located from an interior side lot line, as required by the zoning district regulations.

Minimum Rear Setback: The minimum distance that a building or structure is located from a rear lot line, as required by the zoning district regulations.

Minimum Setback Adjacent to a Residential District: The minimum distance that a building or structure is located from any lot line shared with a lot located in a residential district, as required by the zoning district regulations.

Minimum Street Frontage: The minimum proportion of a principal building required to be located adjacent to a right-of-way expressed as a percentage of the total length of the lot line adjacent to the right-of-way.

Mobile Food Facility: A motorized vehicle or mobile food unit, such as a pushcart, that is used to sell food items.

Mobile Home Dwelling: A trailer or transportable structure designed for dwelling purposes which includes permanent provisions for living, sleeping, eating, cooking, and sanitation.

Mobile Home Park: A zoning lot with facilities for the long-term occupancy of mobile home dwellings.

Model Unit: A building or structure displayed as an example of the dwelling units available for sale or for rent in a residential development. A "Model Unit" may include sales or rental offices. "Model Unit" does not include "Dwelling Unit."

Monument Sign: A sign mounted to a freestanding base with a width equal to or greater than the width of the sign. A monument sign does not include freestanding poles and is not attached to a building.

Motor Vehicle Operations Facility: A facility for the dispatch, storage, and maintenance of emergency medical vehicles, taxis, school buses, and livery vehicles. "Motor Vehicle Operations Facility" does not include "Motor Vehicle Rental," "Motor Vehicle Repair and/or Service," "Motor Vehicle Sales," or "Government Facilities" that dispatch, store, and maintain fire, police, public works, and other municipal vehicles.

Motor Vehicle Rental: An establishment that rents motor vehicles, including incidental facilities for parking and servicing such vehicles. "Motor Vehicle Rental" does not include "Motor Vehicle Operations Facility."

Motor Vehicle Repair and/or Service: An establishment that provides services to adjust, align, repair, repaint, and/or replace motor vehicle parts and systems. "Motor Vehicle Repair and/or Service" includes facilities that sell motor vehicle parts and supplies in an incidental manner to the establishment's repair facilities. "Motor Vehicle Repair and/or Service" does not include "Gas Station," "Motor Vehicle Rental," "Motor Vehicle Repair and/or Service Body Shop," or "Motor Vehicle Sales."

Motor Vehicle Repair and/or Service Body Shop: An establishment that provides services to adjust, align, repair, repaint, and/or replace motor vehicle parts and systems, including body work. "Motor Vehicle Repair and/or Service Body Shop" includes facilities that sell motor vehicle parts and supplies in an incidental manner to the establishment's repair facilities. "Motor Vehicle Repair and/or Service, Body Shop" does not include "Gas Station," "Motor Vehicle Rental," "Motor Vehicle Repair and/or Service," or "Motor Vehicle Sales."

Motor Vehicle Sales: An establishment that sells or leases new or used motor vehicles, including incidental facilities for parking and servicing such vehicles.

Moving Sign: A sign that moves or gives the appearance of movement, including any sign that revolves, rotates, or in any way alters position by natural or artificial means. "Moving Signs" do not include barber poles, "Electronic Message Signs," "Flags," "Inflatable Devices," "Pennant Signs," signs displaying time and temperature, street clocks, and similar such signs.

Multiple-Unit Dwelling: A building that contains three or more dwelling units where each unit has an individual entrance to a common stairway, hallway, or to the outdoors. "Multiple-Unit Dwelling" does not include "Townhouse Dwelling" or "Two-Unit Dwelling."

Nit: A unit of luminous intensity equal to one candela per square meter.

Nonconforming Lot: A lot of record that at one time conformed to applicable zoning regulations, but no longer conforms due to subsequent amendments to this Ordinance.

Nonconforming Site Element: A site characteristic that at one time conformed to applicable development regulations, but no longer conforms due to subsequent amendments to this Ordinance, including impervious coverage, off-street parking and loading, landscaping, lighting, signs, or other similar characteristics of a site.

Nonconforming Structure: A principal or accessory structure that at one time conformed to applicable zoning regulations, but no longer conforms due to subsequent amendments to this Ordinance.

Nonconforming Use: A use of land or a structure that at one time conformed to applicable zoning regulations, but no longer conforms due to subsequent amendments to this Ordinance.

Nursing Home: A residential facility that provides ongoing medical care and inpatient services for people requiring regular medical attention. Such facilities do not provide emergency medical services, surgical services, or treatment for alcoholism, drug addiction, or mental illness. A “Nursing Home” does not include “Assisted Living Facility,” “Community Residence,” or “Independent Living Facility.”

Obscene Sign: A sign that displays content in which the dominant theme of the material depicts prurient representations of sexual matters that affront contemporary community standards and do not possess redeeming social value.

Off-Premises Parking Facility: A parking facility that is not located on the same premises as the use which it serves.

Off-Premises Sign: A sign that directs attention to a business, product, service, or other commercial activity that is conducted, sold, or offered at a location other than the premises where such sign is located. “Off-Premises Sign” does not include “Driveway Access Sign.”

Off-Street Parking: An area used to park a motor vehicle that is not located within a right-of-way.

Off-Street Loading Facility: An area not located within a right-of-way that is provided and maintained for the temporary parking of motor vehicles in order to load and unload materials for commercial, civic, institutional, industrial, and multiple-unit dwelling uses.

On-Street Parking: An area located within a right-of-way that is used to park a motor vehicle.

Open Fence: A barrier typically constructed of treated wood, simulated wood, PVC, steel, or a combination of materials, that is erected to separate, screen, or enclose an area, which has at least 50 percent open spaces. Refer to Figure 13.02.5 Open Fence.

Figure 13.02.5 Open Fence.

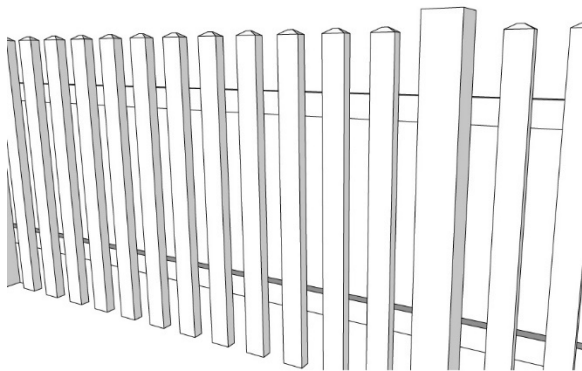

Outdoor Dining: An outdoor seating area that is typically connected to an indoor seating area for a “Restaurant” or “Bar/Tavern.”

Outdoor Entertainment: An open air or partially enclosed structure in which spectator uses are conducted by a for-profit entity that typically charges patrons a fee to enter. Typical “Outdoor Entertainment” uses include, but are not limited to, outdoor theaters, outdoor music venues, outdoor sports arenas, and amusement parks. “Outdoor Entertainment” uses may include refreshment stands that provide products for consumption on the premises. “Outdoor Entertainment” does not include “Outdoor Recreation.”

Outdoor Fireplace or Fire Pit: An outdoor area to burn materials that is equipped with a hearth and chimney, or that is open in design, and is generally constructed of steel, concrete, clay, or other noncombustible material.

Outdoor Recreation: An open air or partially enclosed structure in which recreational activities are conducted by a for-profit entity that typically charges patrons a fee to enter. Typical “Outdoor Recreation” uses may include, but are not limited to, outdoor miniature golf courses, outdoor swimming pools, outdoor tennis courts, and outdoor skating facilities. “Outdoor Recreation” uses may include refreshment stands that provide products for consumption on the premises. “Outdoor Recreation” does not include “Outdoor Entertainment,” “Park,” “Elementary, Middle, or High School.”

Outdoor Sales and Display Area: An area for the sales and display of products and services outside of a building or structure that is accessory to a principal use.

Outdoor Storage Area¹²: An area for the storage of materials, equipment, machinery, or vehicles with a license plate class other than Class A or B used in the conduct of a business.

Owner: The legal or beneficial title-holder of land, or the holder of a written option to contract or purchase the land.

¹² Amended per Ordinance 1929.

Painted Wall Sign: A sign painted directly on the surface of the wall of a building, structure, or environmental feature.

Parapet Roof: A low wall that projects above a roof along the perimeter of a building.

Park: An area for active recreation, passive recreation, and/or resource protection that is open to the public. "Park" may include, but are not limited to, baseball fields, football fields, soccer fields, basketball courts, tennis courts, playgrounds, water parks, and field houses. "Park" does not include "Indoor Recreation" or "Outdoor Recreation."

Parking Lot Perimeter Landscape: A planted area located between the boundary of a parking lot and a right-of-way.

Parking Lot (Primary Use): A paved area not located within a right-of-way that is used to park motor vehicles and is not ancillary to any other use on the same lot. "Parking Lot (Primary Use)" does not include "Outdoor Storage Area."

Parking Lot Sign: A sign regulating a parking lot, with a message such as "No Parking" or "Tow Zone," that is oriented to an off-street parking area.

Patio: A roofless hard surfaced area typically constructed of masonry, brick, or concrete that is attached to the ground adjacent to the wall of a building.

Paved Parking Area: A motor vehicle parking area located adjacent to the entrance to a garage.

Pawn Shop: An establishment licensed, certified, or accredited by the appropriate local and state agencies that lends money in exchange for personal property that is used as collateral. "Pawn Shops" may purchase personal property outright or on the condition of selling it back to a customer with interest. "Pawn Shops" may include cash for gold establishments, which have the primary business of purchasing precious metals, jewelry, watches, and other similar items. "Pawn Shop" does not include "Retail Goods Establishments" such as antique stores and consignment stores.

Payday or Title Loan Establishment: An establishment that provides loans to individuals in exchange for personal checks or titles to motor vehicles. "Payday or Title Loan Establishment" does not include "Currency Exchange" or "Financial Institution."

Pennant Sign: A sign consisting of tapered flags made of lightweight material that are hung in a series and may or may not contain a message. "Pennant Signs" do not include "Banner Flag Signs" or "Flags."

Pergola: A freestanding structure with columns or posts topped with beams and open rafters, which may or may not be connected to the wall of a building.

Permanent Sign: A sign constructed of durable materials that is intended to be displayed for the duration of time that the use or occupant is located on the premises.

Permitted Use: A use that is allowed to be established by-right in a zoning district, and does not require administrative review or approval.

Person: An individual, firm, corporation, partnership, or other similar entity.

Personal Services Establishment: A commercial enterprise primarily engaged in the provision of services of a personal nature. "Personal Service Establishment" uses may include, but are not limited to, dry cleaners, barbershops, beauty salons, animal day care establishments, animal grooming establishments, shoe repair shops, and tailor shops. "Personal Service Establishment" also includes commercial educational facilities, such as driving schools, dance schools, and tutoring facilities. "Personal Service Establishment" includes facilities that sell products and goods in an incidental manner to the establishment's provision of services. "Personal Services Establishment" does not include "Adult Use," "Animal Boarding, Hospital, or Shelter" or "Tattoo Parlor."

Pitched Roof: A pitched or sloped roof, including hipped roofs, gabled roofs, roofs with a combination of hips and gables, gambrel roofs, and mansard roofs.

Place of Worship: An institution maintained by a religious body where people assemble for religious purposes, ceremonies, and other similar events. "Place of Worship" may include housing for members of religious orders, "Day Care Centers," "Preschools," or "Elementary, Middle, or High Schools."

Planned Unit Development: A distinct category of special use permit intended to allow flexibility in the application of the standards of this Ordinance. "Planned Unit Developments" are intended for significant development proposals that provide amenities to the community which are not required from conventional development applications.

Planning and Zoning Commission: The Planning and Zoning Commission of the Village of Montgomery, Illinois.

Plat: A document that displays property lines and other information for the purpose of identifying and/or dividing land.

Pole Sign: A sign mounted to one or more freestanding poles that does not include a freestanding base and is not attached to a building. "Pole Sign" does not include "Driveway Access Sign."

Porch: An unenclosed roofed platform projecting from the exterior wall of a building.

Portable Sign: A sign with a supporting structure that is designed to be moved or relocated for display. Portable signs include, but are not be limited to, signs mounted upon a trailer or other non-motorized mobile structure, which may or may not possess wheels. "Portable Signs" do not include "A-Frame Signs" or "Manually Changeable Copy Signs." Refer to [Figure 13.02.6 Portable Sign](#).

Figure 13.02.6 Portable Sign.

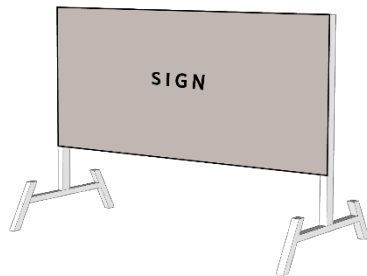

Principal Structure: A structure where the primary use of the lot is conducted.

Principal Use: The primary use of a lot or building as distinguished from an accessory use, which may be designated as a permitted use or a special use.

Professional Office: An establishment that engages in the application, processing, or manipulation of business information or professional expertise, or that offer health-related outpatient treatment by licensed health professionals. A “Professional Office” must not manufacture, assemble, warehouse, or repair goods and products for the retail or wholesale market, or engage in the repair of products or the provision of retail services. “Professional Office” may include, but is not limited to, medical offices, dental offices, law firms, insurance agencies, accounting firms, real estate agencies, investment firms, and non-profit organizations. “Professional Office” does not include “Government Facility.”

Projecting Sign: A sign attached to a building or other structure that extends beyond the surface of the building and is typically oriented perpendicular to the façade of the building. “Projecting Signs” do not include “Awning Signs” or “Marquee Signs.”

Rain Barrel: A container for storing rainwater installed above-grade that generally has a capacity of less than 500 gallons.

Rain Garden: A shallow vegetated basin that collects and absorbs stormwater runoff.

Rainwater Cistern: A container for storing rainwater that may be installed either above or below grade.

Rear Façade: Any façade that faces and is most closely parallel to the rear lot line.

Rear Lot Line: The boundary of a lot that is most distant from and approximately parallel to the front lot line. If the rear lot line is less than 10 feet in length, or if the lot forms a point in the rear, then the rear lot line is considered a line that is 10 feet in length between the side lot lines that is most distant from and approximately parallel to the front lot line. Refer to [Figure 10 13.02.3 Lot Lines and Yards.](#)

Rear Yard: The area on a lot extending from the rear façade of a building to the rear lot line between the side lot lines on an interior lot, and between the side lot line and the corner side yard on a corner lot. Refer to [Figure 13.02.3 Lot Lines and Yards.](#)

Recreation Equipment: Structures typically used for children’s active recreation, which may include, but not be limited to swing sets and jungle gyms. “Recreation Equipment” does not include “Treehouse.”

Recreational Vehicle: Vehicles or trailers for recreational or utilitarian uses that can be driven, towed, hauled, sailed, or flown. “Recreational Vehicle” includes, but is not limited to, snowmobiles, all-terrain vehicles, race cars, off-road vehicles, travel trailers, pull campers, motorhomes, tent trailers, special purpose trailers, cargo trailers, utility trailers, vehicle trailers, power boats, cruisers, jet skis, fishing boats, hunting boats, pontoon boats, personal watercraft, row boats, and sail boats. “Recreational Vehicle” does not include “Dwelling Unit.”

Refuse, Recycling, or Grease Container: A receptacle for the disposal of litter, recyclables, or grease.

Research/Development Facility: A facility in which ideas and technologies are investigated, tested, and refined in industries that may include, but is not limited to, electronics, computer hardware and software, communications, information technology, biotechnology, and pharmaceuticals. “Research/Development Facility” may include the incidental manufacture and/or sale of products developed at the facility.

Residential Care Facility: A group care facility licensed for 24-hour medical or non-medical care of people in need of supervision or assistance essential for daily living, or for the protection of the individual. A “Residential Care Facility” includes “Assisted Living Facility,” “Independent Living Facility,” “Nursing Home,” hospice, and continuum of care facilities. A “Residential Care Facility” does not include “Community Residence.”

Residential Sign: A permanent sign located on a lot in a residential zoning district.

Restaurant: An establishment that prepares and sells food and beverages for consumption on the premises and/or for carry-out. “Restaurant” does not include refreshment stands incidental to “Indoor Entertainment,” “Indoor Recreation,” “Outdoor Entertainment,” or “Outdoor Recreation” uses.

Retail Goods Establishment: A commercial establishment that provides physical goods, products, or merchandise directly to the consumer for purchase and removal from the premises by the purchaser. “Retail Goods Establishment” may include, but is not limited to, grocery stores, clothing stores, jewelry stores, appliance stores, electronics stores, furniture stores, office supply stores, bookstores, and sporting goods stores. “Retail Goods Establishment” does not include “Adult Use,” “Cannabis Dispensary” or “Pawn Shop.”

Reverse Corner Lot: A type of corner lot where the corner side lot line is adjacent to the front lot line of the lot to its rear. See [Figure 13.02.2 Lot Types](#).

Right-of-Way: Land dedicated or utilized for a street, trail, sidewalk, utility, railroad, or other similar purpose.

Roof Sign: A sign erected on the roof of a building that projects above the highest point of the roofline or parapet wall.

Satellite Dish: A parabolic antenna designed to send and/or receive television, radio, communication, data, or other similar signals from satellites and antennas.

Screening: Structures or landscaping elements used to conceal adjacent buildings or structures.

Self-Service Storage: A facility used for the storage of personal property where individuals rent storage spaces of various sizes on an individual basis.

Semi-Pervious Coverage: The proportion of the area of a zoning lot occupied by surfaces that allow at least 50% stormwater infiltration. Semi-pervious surfaces may include, but is not limited to, pervious pavers, permeable asphalt, permeable concrete, green roofs, and blue roofs.

Service Walk. A paved area on a zoning lot connecting the front yard to the rear yard that may or may not be connect to a public right-of-way.

Setback: The minimum or maximum distance that a building or structure is located from a lot line, as required by the zoning district regulations

Shade Tree: A deciduous tree, generally having a single stem, planted primarily for shade. Trees with an expected canopy of over 40 feet are considered large shade trees. Trees with an expected canopy of 30 to 40 feet are considered medium shade trees.

Shared Lane Marking or Sharrow: Road marking used to indicate a shared travel lane for bicycles and motor vehicles.

Shed: A relatively small building typically used to store lawn, garden, and/or swimming pool equipment.

Short-Term Bicycle Parking: Bicycle parking intended primarily for short-term use. Bicycles are typically secured to short-term parking facilities by means of a bicycle lock.

Sign: A message, image, display, or object used to advertise, direct attention to, or promote the interests of a person, business, organization, location, product, service, or activity. "Signs" do not include works of art.

Sill: A projecting horizontal architectural feature, often located below a window or door.

Single-Unit Dwelling: A building that contains one dwelling unit, which is not attached to any other dwelling units.

Small Wind Energy System (Building-Mounted): An energy collection system that converts wind energy into electricity for on-site use. Small wind energy systems generally consist of a turbine, mounting device, and associated control electronics. Building-mounted systems are attached to existing buildings and structures that are constructed for a use other than supporting the small wind energy system.

Small Wind Energy System (Ground-Mounted): An energy collection system that converts wind energy into electricity for on-site use. Small wind energy systems generally consist of a turbine, mounting device, and associated control electronics. Ground-mounted systems are freestanding structures that are directly anchored to the ground.

Snipe Sign: A sign affixed, hung, placed, applied, or posted to any tree, utility pole, hydrant, bench, fence, stake, trash receptacle, sidewalk, curb, parkway, street, median, or similar location, located on either public or private property, without the consent of the property owner.

Solar Energy System (Building-Mounted): An energy collection system that converts sunlight into electric or mechanical power for on-site use. Solar energy systems consist of photovoltaic panels or flat plate collectors, mounting devices, and associated control electronics. Building-mounted systems are attached to existing buildings and structures that are constructed for a use other than supporting the solar energy system.

Solar Energy System (Ground-Mounted): An energy collection system that converts sunlight into electric or mechanical power for on-site use. Solar energy systems consist of photovoltaic panels or flat plate collectors, mounting devices, and associated control electronics. Ground-mounted systems are freestanding structures that are directly anchored to the ground.

Solid Fence: A barrier typically constructed of treated wood, simulated wood, PVC, steel, or a combination of materials, that is erected to separate, screen, or enclose an area, which has less than 50 percent open spaces. Refer to Figure 13.02.7 Solid Fence.

Figure 13.02.7 Solid Fence.

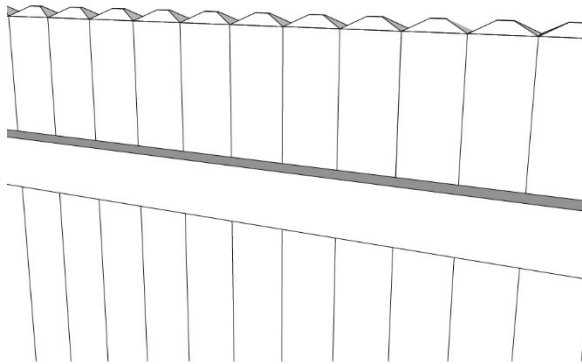

Special Use: A use that has unique characteristics inherent in its operation that may be allowed in a zoning district following administrative review and approval.

Stacking Space: A space designated as a waiting area, or queuing area, for vehicles at a drive-through establishment.

Stairs: A structure made up of a series of steps used to move from one level of a building or structure to another.

Stoop: A structure made up of stairs and a landing used to access a building or structure.

Structure: Anything constructed or erected that requires location on the ground or must be attached to something located on the ground.

Stealth Design: A technique that reduces the visual impact of a structure by enclosing, camouflaging, screening, or obscuring the structure in relation to the architectural features of a larger building or structure.

Story: The portion of a building included between a floor and the floor above it, or if there is no floor above it, the space between the floor and the ceiling above the floor. A basement is counted as a story for the purpose of measuring building height if more than half of its height is above grade.

Street Address Sign: A sign that displays the name or address of the occupant.

Structural Soil: Soil that includes aggregate to support concrete sidewalks and asphalt parking lots while providing nourishment to plant roots.

Swimming Pool: An in-ground or aboveground basin of water constructed for swimming or wading.

T-Frame Sign: A movable sign placed on the ground and constructed in the shape of a “T” or some variation thereof.

Tandem Parking: A parking area consisting of two or more parking spaces placed one behind the other, with the space nearest to the driveway or street serving as the only means of access to the other space.

Temporary Outdoor Entertainment: A live event that is intended to be in place for a limited period of time within an outdoor space. “Temporary Outdoor Entertainment” may include, but is not limited to, animal shows, carnivals, circuses, fireworks shows, live music, outdoor theater, and worship services.

Temporary Outdoor Sale: The outdoor sale and display of merchandise of a seasonal nature, such as pumpkins or Christmas trees.

Temporary Sign: A sign that is intended to be displayed for a limited period of time.

Temporary Storage Container: A temporary, moveable structure that may be used for the storage of possessions or products prior to being transported to a storage facility, or for collecting waste and other material associated with the construction and renovation of a structure.

Temporary Structure: A structure that is intended to be in place for a limited period of time, which is typically constructed without a foundation.

Temporary Window Sign: A sign affixed, hung, placed, applied, or posted on the interior or exterior of a building window or door that is intended to be displayed for a limited period of time.

Temporary Use: A use that is intended to be in place for a limited period of time.

Through Lot: An interior lot having frontage on two generally parallel streets that do not intersect. On a through lot, both lot lines adjacent to the right-of-way are considered front lot lines. See [Figure 13.02.2 Lot Types](#).

Townhouse Dwelling: A building that contains three or more dwelling units where each unit has an individual entrance to the outdoors and each unit is attached vertically using one or more party walls. “Townhouse Dwelling” does not include “Two-Unit Dwelling” or “Multiple-Unit Dwelling.”

Train Station: A facility used for boarding and alighting passenger trains. Train stations may include platforms, station houses, benches, walkways, signaling equipment, and other structures necessary for passenger rail travel. Train stations do not include facilities for storing or repairing railroad vehicles or equipment, or facilities for loading and unloading freight.

Transitional Treatment Facility: A facility that provides supervision, counseling, and therapy for individuals recovering from addiction that is licensed, certified, or accredited by the appropriate state or federal agencies

Tree Canopy Coverage: The proportion of a parking lot that is shaded by trees.

Treehouse: An accessory structure supported by one or more trees. “Treehouse” does not include “Recreation Equipment.”

Trellis: A vertical latticework structure used in a garden to support climbing plants.

Two-Unit Dwelling: A building that contains two dwelling units where each unit has an individual entrance to a common stairway, hallway, or to the outdoors. “Two-Unit Dwelling” does not include “Townhouse Dwelling” or “Multiple-Unit Dwelling.”

Unshielded Lighting: A fixture that allows light to be emitted above a horizontal plane from the lowest point of the fixture that emits light.

Use: The purpose or activity for which a lot, building, or structure is designed, intended, occupied, or maintained.

Utility: The use of land for infrastructure facilities including, but not limited to, services for gas, electricity, water treatment and storage, sewage treatment and storage, telephone, cable television, data, cellular, and fiber-optic cable.

Utility-Scale Solar Energy System: An energy collection system that converts sunlight into electricity for off-site use by utility customers. “Utility-Scale Solar Energy Systems” consist of photovoltaic panels, mounting devices, and associated control electronics to provide electricity to the power grid.

Utility-Scale Wind Energy System: An energy collection system that converts wind energy into electricity for off-site use by utility customers. “Utility-Scale Wind Energy Systems” consist of a turbine, a monopole tower, and associated control electronics to provide electricity to the power grid.

Variation: Authorization granted by the Village to allow development that deviates from the specific regulations of this Ordinance.

Vehicle for Sale Sign: A sign used to sell a new or used vehicle, often placed in the window of the vehicle.

Vehicle Sign: A sign attached to or placed on a vehicle that is prominently visible from the public right-of-way where the primary purpose of the vehicle is to advertise a business, product, or service rather than to be actively used or available for the daily function of the business to which the sign relates. "Vehicle Sign" does not include a vehicle for sale sign advertising a vehicle for lease or sale.

Video Display Sign: A sign that displays a message with text, detailed images, or video using digital screens, LED screens, plasma screens, flat screens, video screens, and holographic displays. "Video Display Sign" does not include "Electronic Message Sign."

Village: The Village of Montgomery, Illinois.

Vocational School: A facility that offers instruction in industrial, clerical, commercial, managerial, building trades, or automotive skills. "Vocational School" does not include "Elementary, Middle, or High School" or "College or University."

Wall: A vertical structure, typically constructed of concrete, stone, brick, masonry, or other similar material, that creates a physical barrier for light and air.

Wall Sign: A sign mounted flat against the wall of a building or structure that is typically oriented parallel to the wall to which it is attached.

Warehousing, Storage, or Distribution Facility: An establishment that stores and transports products or equipment, including, but not limited to warehouses, fulfillment centers, moving companies, storage facilities, freight transportation, and truck terminals.

Warning Sign: A sign that communicates a message of warning, danger, or caution, such as "Private Property," "No Trespassing," or "Beware of Dog."

White Roof: A roof that is white or light in color that provides high levels of solar reflectance and reduces the heat absorbed by a building or structure.

Window Sign: A sign affixed, hung, placed, applied, or posted on the interior or exterior of a window or door which is intended to be viewed from the exterior of a building.

Wireless Telecommunication Antenna: A structure that may be larger than six cubic feet in volume that is used to transmit and/or receive communication, data, or other similar signals in order to facilitate the use of wireless devices. "Wireless Telecommunications Antenna" does not include "Antenna," "Satellite Dish," or "Wireless Telecommunication Small Cell."

Wireless Telecommunication Facility: A structure used to protect the equipment that processes communication, data, or other similar signals in order to facilitate the use of wireless devices.

Wireless Telecommunication Small Cell: A structure that is smaller than six cubic feet in volume that is used to transmit and/or receive communication, data, or other similar signals in order to facilitate the use of wireless devices. "Wireless Telecommunications Small Cell" does not include "Antenna," "Satellite Dish," "Wireless Telecommunication Antenna."

Wireless Telecommunication Tower: A structure designed and constructed to support one or more “Wireless Telecommunications Antennas” and all devices attached to it. “Wireless Telecommunication Towers” are typically freestanding and may be of either lattice or monopole construction.

Yard: The area on a lot between the principal structure and the lot line.

Yard Sign: A temporary freestanding sign that is placed in a yard.

Zoning District: A designation given to each lot within the Village under which certain development regulations and requirements are consistent.

Zoning Lot: One or more lots located within a block that is under single ownership and is designated as a unit of land for development by the owner of such land.

Zoning Map: The map incorporated into this Ordinance, which designates the boundaries of the zoning districts of the Village.

Zoning Officer: The person charged with the responsibility of administering and enforcing the Montgomery Unified Development Ordinance.