

Village of Leonard Oakland County, Michigan



ZONING ORDINANCE #19

TABLE OF CONTENTS

PREAMBLE	i
ARTICLE I SHORT TITLE	1.1
ARTICLE II CONSTRUCTION OF LANGUAGE	2.1
ARTICLE III DEFINITIONS	3.1
ARTICLE IV GENERAL PROVISIONS	4.1
Section 4.01 – Conflicting Regulations	4.1
Section 4.02 – Scope.....	4.1
Section 4.03 – Street, Alley, and Railroad Right-of-Way	4.1
Section 4.04 – Permitted Uses	4.1
Section 4.05 – Permitted Area	4.1
Section 4.06 – Necessity of Continuing Compliance	4.1
Section 4.07 – Exceptions to Height Limitations	4.2
Section 4.08 – One Single-Family Dwelling Per Lot	4.2
Section 4.09 – Reserved.....	4.2
Section 4.10 – Yard Encroachments.....	4.2
Section 4.11 – Frontage	4.3
Section 4.12 – Corner Lot Setbacks in Residential Districts	4.3
Section 4.13 – Obstruction to Vision on Corner Lots.....	4.3
Section 4.14 – Dwelling in Non-Residential Districts.....	4.3
Section 4.15 – Occupancy of Garages, Accessory Buildings and Basement Apartments Prohibited	4.3
Section 4.16 – Accessory Buildings, Structures and Uses in Single Family Residential Districts.....	4.3
Section 4.17 – Accessory Buildings in Other than Single Family Residential Districts	4.4
Section 4.18 – Reserved.....	4.4
Section 4.19 – Grades	4.4
Section 4.20 – Dumpster or Outdoor Trash Receptacles and Fixtures	4.5
Section 4.21 – Storage of Obnoxious Matter in Open Containers Prohibited.....	4.5
Section 4.22 – Use of Yard Spaces and Other Open Areas for Storage	4.6
Section 4.23 – Excavation or Holes	4.6
Section 4.24 – Excavation, Removal and Filling of Land	4.6
Section 4.25 – Sewage Disposal	4.6
Section 4.26 – Government Functions.....	4.7
Section 4.27 – Voting Place.....	4.7
Section 4.28 – Reserved.....	4.7
Section 4.29 – Easements	4.7
Section 4.30 – Regulations of Nuisance Activities.....	4.7
Section 4.31 – Temporary and Portable Buildings, Uses, Structure and Special Events	4.7
Section 4.32 – Construction Begun Prior to Adoption of Ordinance	4.8

Section 4.33 – Buildings to be Moved.....	4.8
Section 4.34 – Restoring Unsafe Buildings	4.8
Section 4.35 – Reserved.....	4.8
Section 4.36 – Keeping of Horses, Livestock and Other Animals	4.8
Section 4.37 – Fence, Wall, and Privacy Screen Regulations	4.9
Section 4.38 – Protective Screening of Non-Residential Areas from Residential Areas	4.9
Section 4.39 – Wall, Brick, Facing	4.10
Section 4.40 – Exterior Lighting – See Article XX – Outdoor Lighting.....	4.10
Section 4.41 – Reserved.....	4.10
Section 4.42 – Commercial Television, Telephone, and Radio Towers.....	4.10
Section 4.43 – Performance Guarantees	4.10
Section 4.44 – Commercial Vehicles in Residential Areas	4.12
Section 4.45 – Adult-Regulated Uses	4.12
Section 4.46 – Home Occupations.....	4.15
Section 4.47 – Reserved.....	4.16
Section 4.48 – Enclosure of Roof Appliances or Accessories.....	4.16
Section 4.49 – Landscaping Requirements and Plant Materials, Buffer Strip and Greenbelt Standards	4.16
Section 4.50 – Parking and Storage of Campers, Travel Trailers and Boats.....	4.18
Section 4.51 – Sidewalks or Bikeways	4.19
Section 4.52 - Reserved	4.19
Section 4.53 – Satellite Dish Antennae.....	4.19
Section 4.54 – Residential Design Standards	4.19
Section 4.55 – Reserved.....	4.23
Section 4.56 – Automobile Service Stations and Public Garages	4.23
Section 4.57 – Outdoor Wood Fired Stove or Furnace.....	4.25
Section 4.58 – Reserved.....	4.27
Section 4.59 – Wind Energy Systems.....	4.27
Section 4.60 – Reserved.....	4.30
Section 4.61 – Reserved.....	4.30
Section 4.62 – Condominium Projects.....	4.30
Section 4.63 – Single Family Cluster Option	4.34
Section 4.64 – Approval of Plats	4.38

ARTICLE V NONCONFORMITIES.....5.1

Section 5.01 – Intent	5.1
Section 5.02 – Nonconforming Uses of Land.....	5.1
Section 5.03 – Nonconforming Uses of Structures.....	5.1
Section 5.04 – Nonconforming Structures	5.2
Section 5.05 – Nonconforming Lots of Record	5.4
Section 5.06 – Reserved.....	5.5
Section 5.07 – Uses under Special Approval Provisions not Nonconforming Uses	5.5
Section 5.08 – Change of Tenancy or Ownership	5.5

Section 5.09 – Certificate of Occupancy for Nonconforming Uses	5.5
Section 5.10 – Record of Nonconforming Uses	5.6
Section 5.11 – Reserved.....	5.6
Section 5.12 – Plans Already Filed.....	5.6
Section 5.13 – Removal of Nonconforming Uses and/or Structures	5.6
Section 5.14 – Nonconforming Use Determinations	5.6
ARTICLE VI OFF-STREET PARKING AND LOADING REQUIREMENTS	6.1
Section 6.01 – Off-Street Parking Required	6.1
Section 6.02 – Off-Street Parking Requirements.....	6.3
Section 6.03 – Reserved.....	6.8
Section 6.04 – Off-Street Parking Space Layout, Standards, Construction and Maintenance	6.8
Section 6.05 – Parking Lot Landscaping and Screening	6.11
Section 6.06 – Reserved.....	6.12
Section 6.07 – Off-Street Loading and Unloading	6.12
Section 6.08 – Parking Layouts	6.12
ARTICLE VII PERFORMANCE STANDARDS	7.1
Section 7.01 – Intent and Scope of Application.	7.1
Section 7.02 – Performance Standards.	7.1
Section 7.03 – Procedures for Determining Compliance.....	7.5
ARTICLE VIII ZONING DISTRICTS AND MAP	8.1
Section 8.01 – Establishment of Districts	8.1
Section 8.02 – Zoning Map.....	8.1
Section 8.03 – Interpretation of Boundaries	8.1
Section 8.04 – Alteration of Zoning Districts.....	8.2
ARTICLE IX R-1 and R-2 - SINGLE FAMILY RESIDENTIAL DISTRICTS	9.1
Section 9.01 – Statement of Purpose	9.1
Section 9.02 – Permitted Principal Uses.....	9.1
Section 9.03 – Permitted Uses after Special Approval	9.2
Section 9.04 – Reserved.....	9.4
Section 9.05 – Area, Height, Bulk and Placement Requirements	9.4
Section 9.06 – Site Plan Review	9.5
Section 9.07 – Environmental Impact Assessment.....	9.5
ARTICLE X M-D - MULTIPLE FAMILY RESIDENTIAL DISTRICT.....	10.1
Section 10.01 – Statement of Purpose	10.1
Section 10.02 – Permitted Principal Uses.....	10.1
Section 10.03 – Permitted Uses after Special Approval	10.1
Section 10.04 – Site Development Standards for Multiple Family Developments	10.5
Section 10.05 – Area, Height, Bulk and Placement Requirements	10.10
Section 10.06 – Site Plan Review	10.10
Section 10.07 – Environmental Impact Assessment.....	10.10

ARTICLE XI MHP - MANUFACTURED HOME PARK DISTRICT11.1

 Section 11.01 – Intent 11.1

 Section 11.02 – Statutory Provisions 11.1

 Section 11.03 – Permitted Uses and Structures 11.1

 Section 11.04 – Permitted Uses after Special Approval 11.2

 Section 11.05 – Reserved..... 11.2

 Section 11.06 – Development Standards 11.2

ARTICLE XII AG - AGRICULTURAL DISTRICT12.1

 Section 12.01 – Statement of Purpose 12.1

 Section 12.02 – Principal Permitted Uses 12.1

 Section 12.03 – Permitted Uses after Special Approval 12.2

 Section 12.04 – Area, Height, Bulk and Placement Requirements 12.6

 Section 12.05 – Site Plan Review 12.6

 Section 12.06 – Environmental Impact Environmental
 Impact Assessment 12.6

ARTICLE XIII R - 1F SMALL FARM DISTRICT13.1

 Section 13.01 – Statement of Purpose 13.1

 Section 13.02 – Permitted Principal Uses 13.1

 Section 13.03 – Permitted Uses after Special Approval 13.2

 Section 13.04 – Area, Height, Bulk and Placement Requirements 13.4

 Section 13.05 – Site Plan Review 13.4

 Section 13.06 – Environmental Impact Assessment..... 13.4

ARTICLE XIV C-1 - VILLAGE COMMERCIAL DISTRICT14.1

 Section 14.01 – Statement of Purpose 14.1

 Section 14.02 – Permitted Principal Uses 14.1

 Section 14.03 – Permitted Uses after Special Approval 14.2

 Section 14.04 – Required Conditions for Village Commercial Uses 14.5

 Section 14.05 – Area, Height, Bulk, and Placement Requirements. 14.6

 Section 14.06 – Site Plan Review 14.6

 Section 14.07 – Environmental Impact Assessment..... 14.6

ARTICLE XV LI - LIMITED INDUSTRIAL DISTRICT15.1

 Section 15.01 – Statement of Purpose 15.1

 Section 15.02 – Permitted Principal Uses 15.1

 Section 15.03 – Permitted Uses after Special Approval 15.2

 Section 15.04 – Required Conditions for Industrial Uses..... 15.7

 Section 15.05 – Area, Height, Bulk and Placement Requirements 15.7

 Section 15.06 – Site Plan Review 15.8

 Section 15.07 – Environmental Impact Assessment..... 15.8

ARTICLE XVI PUD - PLANNED UNIT DEVELOPMENT16.1

 Section 16.01 – Statement of Intent 16.1

 Section 16.02 – Permitted Principal Uses 16.1

 Section 16.03 – Regulations 16.1

Section 16.04 – Reserved.....	16.5
Section 16.05 – Pre-Application Conference (Optional).....	16.5
Section 16.06 – Application Procedures.....	16.5
Section 16.07 – Review and Standards for Approval.....	16.6
Section 16.08 – Enforcement.....	16.9
Section 16.09 – Revision of Approved Plans	16.10
ARTICLE XVII PR – PARKS AND RECREATION DISTRICT	17.1
Section 17.01 – Statement of Purpose	17.1
Section 17.02 – Permitted Principal Uses.....	17.1
Section 17.03 – Permitted Uses after Special Approval.....	17.1
Section 17.04 – Area, Height, Bulk and Placement Requirements	17.1
Section 17.05 – Site Plan Review	17.1
Section 17.06 – Environmental Impact Assessment.....	17.2
ARTICLE XVIII SCHEDULE OF REGULATIONS.....	18.1
Section 18.01 – Area, Height, Bulk and Placement Requirements for all Zoning Districts	18.1
Section 18.02 – Notes to Schedule of Regulations.....	18.2
ARTICLE XIX SIGNS.....	19.1
Section 19.01 – Statement of Purpose	19.1
Section 19.02 – Definitions.....	19.1
Section 19.03 – Exempt Signs	19.3
Section 19.04 – Prohibited Signs.....	19.4
Section 19.05 – General Standards for Permitted Signs.....	19.5
Section 19.06 – Reserved.....	19.7
Section 19.07 – District Regulations	19.7
Section 19.08 – Non – Conforming Signs	19.8
Section 19.09 – Sign Permits.....	19.8
ARTICLE XX OUTDOOR LIGHTING	20.1
Section 20.01 – Statement of Purpose and Intent	20.1
Section 20.02 – Definitions.....	20.1
Section 20.03 – Conflicting Regulations	20.4
Section 20.04 – Reserved.....	20.4
Section 20.05 – Approved Materials and Methods of Construction or Installation/Operation	20.4
Section 20.06 – Preferred Source.....	20.5
Section 20.07 – Lighting Requirements.....	20.5
Section 20.08 – Parking Lot Lighting Standards	20.8
Section 20.09 – Reserved.....	20.8
Section 20.10 – Temporary Lighting Permits.....	20.8
Section 20.11 – Nonconforming Uses	20.8
Section 20.12 – Variances.....	20.9
Section 20.13 – Applicability	20.10

**ARTICLE XXI WIRELESS TELECOMMUNICATION TOWERS
AND ANTENNAS21.1**

Section 21.01 – Purpose..... 21.1
 Section 21.02 – Definitions..... 21.1
 Section 21.03 – Applicability 21.2
 Section 21.04 – Essential Services..... 21.3
 Section 21.05 – Reserved..... 21.3
 Section 21.06 – General Requirements..... 21.3
 Section 21.07 – Cable Micro cell Networks 21.5
 Section 21.08 – Administratively Approved Uses..... 21.6
 Section 21.09 – Special Approvals 21.7
 Section 21.10 – Reserved..... 21.12
 Section 21.11 – Buildings or Other Equipment Storage..... 21.12
 Section 21.12 – Removal of Abandoned Antennas and Towers 21.12
 Section 21.13 – Nonconforming Uses 21.12

ARTICLE XXII ADMINISTRATION AND ENFORCEMENT22.1

Section 22.01 – Enforcement..... 22.1
 Section 22.02 – Duties of Building Department..... 22.1
 Section 22.03 – Building Permits 22.2
 Section 22.04 – Certificate of Occupancy 22.3
 Section 22.05 – Fees 22.4
 Section 22.06 – Tickets..... 22.4
 Section 22.07 – Reserved..... 22.5
 Section 22.08 – Procedure of Notice 22.5

ARTICLE XXIII PLANNING COMMISSION23.1

Section 23.01 – Creation of Planning Commission:..... 23.1
 Section 23.02 – Membership of the Planning Commission:..... 23.1
 Section 23.03 – Officers of the Planning Commission:..... 23.1
 Section 23.04 – Removal of Planning Commission Members: 23.1
 Section 23.05 – Meetings of the Planning Commission:..... 23.2
 Section 23.06 – Bylaws: 23.2

ARTICLE XXIV ZONING BOARD OF APPEALS.....24.1

Section 24.01 – Creation..... 24.1
 Section 24.02 – Membership of the Zoning Board of Appeals 24.1
 Section 24.03 – Alternate Members..... 24.1
 Section 24.04 – Meetings..... 24.2
 Section 24.05 – Powers of Zoning Board of Appeals..... 24.2
 Section 24.06 – Application of the Variance Power..... 24.2
 Section 24.07 – Limitations on the Powers of the
 Zoning Board of Appeals 24.3
 Section 24.08 – Procedure for Appeals to the Board..... 24.3
 Section 24.09 – Appeal to Circuit Court..... 24.5

ARTICLE XXV SITE PLAN REVIEW25.1

Section 25.01 – Statement of Purpose 25.1
Section 25.02 – Site Plan Approval 25.1
Section 25.03 – Pre – Application Conference (Optional) 25.2
Section 25.04 – Application for Site Plan Approval..... 25.2
Section 25.05 – Required Information..... 25.2
Section 25.06 – Criteria for Approval of Site Plans 25.5
Section 25.07 – Reserved..... 25.7
Section 25.08 – Environmental Impact Assessment..... 25.7
Section 25.09 – Review of Site Plans 25.8
Section 25.10 – Site Plan Approval and Record..... 25.8
Section 25.11 – Reserved..... 25.9
Section 25.12 – Construction under Plan..... 25.9
Section 25.13 – Revocation 25.10
Section 25.14 – Certificate of Occupancy 25.10

ARTICLE XXVI SPECIAL APPROVAL PROCEDURES AND STANDARDS26.1

Section 26.01 – Intent 26.1
Section 26.02 – Public Hearings 26.1
Section 26.03 – Procedure of Notice 26.1
Section 26.04 – Planning Commission Hearing,
Review and Recommendations 26.1
Section 26.05 – Decision by Village Council 26.1
Section 26.06 – Reserved§..... 26.1
Section 26.07 – Site Plan Review and Information Required 26.1
Section 26.08 – Performance Guarantees 26.2
Section 26.09 – Standards..... 26.2
Section 26.10 – Record 26.3
Section 26.10 – Expiration..... 26.3

ARTICLE XXVII CONDITIONAL REZONING.....27.1

Section 27.01 – Purpose..... 27.1
Section 27.02 – Option to Offer Condition(s). 27.1
Section 27.03 – Planning Commission Review..... 27.2
Section 27.04 – Village Council Review..... 27.2
Section 27.05 – Approval. 27.2
Section 27.06 – Compliance with Conditions..... 27.3
Section 27.07 – Time Period for Establishing Development or Use. 27.3
Section 27.08 – Reversion of Zoning. 27.4
Section 27.09 – Subsequent Rezoning of Land. 27.4
Section 27.10 – Amendment of Conditions..... 27.4
Section 27.11 – Village Right to Rezone..... 27.4
Section 27.12 – Failure to Offer Conditions..... 27.5
Section 27.13 – Notice of Adoption. 27.5
Section 27.14 – Rezoning Factors 27.5

ARTICLE XXVIII ENFORCEMENT AND PENALTIES	28.1
Section 28.01 – Violations and Penalties.....	28.1
Section 28.02 – Public Nuisance	28.3
ARTICLE XXIX RESERVED	29.1
ARTICLE XXX RESERVED.....	30.1
ARTICLE XXXI RESERVED	31.1
ARTICLE XXXII RESERVED.....	32.1
ARTICLE XXXIII AMENDMENTS AND NOTICES.....	33.1
Section 33.01 – Statement of Intent.....	33.1
Section 33.02 – Amendment Procedure.....	33.1
Section 33.03 – Protests	33.3
ARTICLE XXXIV INTERPRETATION AND VESTED RIGHT.....	34.1
Section 34.01 – Interpretation and Conflict.....	34.1
Section 34.02 – Vested Right.....	34.1
ARTICLE XXXV REPEALER, SEVERABILITY, EFFECTIVE DATE, ADOPTION.....	35.1
Section 35.01 – Repealer.	35.1
Section 35.02 – Severability.	35.1
Section 35.03 – Savings Clause.....	35.1
Section 35.04 – Adoption.	35.1
Section 35.05 – Effective Date.	35.1

THE VILLAGE OF LEONARD

ZONING ORDINANCE

ORDINANCE NO. 19

PREAMBLE

An Ordinance enacted under the authority of Public Act 110 of 2006, as amended, the Michigan Zoning Enabling Act, MCL 125.3101, et seq., to provide for the establishment in the Village of Leonard for districts and zones within which the use of land and structures, the height, the area, the size, and location of buildings may be regulated by ordinance, and within which district regulations shall be established for the light and ventilation of those buildings, and within which districts or zones the density of population may be regulated by ordinance; to provide for environmental quality; to provide for a healthful environment and air quality through the use of landscaping and planting and preserving trees; to designate the use of certain state licensed residential facilities, to provide by ordinance for the acquisition by purchase, condemnation, or otherwise of private property which does not conform to the regulations and restrictions of the various zones or districts provided; to provide for the administering of this Ordinance; to provide for amendments, supplements, or changes hereto; to provide for conformity with the State housing code or other acts, ordinances, or regulations, and to provide penalties for the violation of the terms of this Ordinance.

ENACTING CLAUSE

The Legislative Body of the Village of Leonard may regulate and restrict the use of land and structures to meet the needs of the Village's residents for food, fiber, energy and other natural resources, places of residence, recreation industry, trade, service, and other use of land; to insure that uses of the land shall be situated in appropriate locations and relationships; to promote preservation of the Village's character; to limit the inappropriate overcrowding of land and congestion of population and transportation systems and other public facilities; to facilitate adequate and efficient provision for transportation systems, sewage disposal, water, energy, education, recreation, and other public service and facility needs; to assist in implementing the Village Master Plan; and to promote public health, safety, and welfare, and for those purposes may divide the Village into districts of the number, shape, and area considered best suited to carry out this Ordinance. For each of those district regulations may be imposed designating the uses for which buildings or structures shall or shall not be erected or altered, and designating the trades, industries, and other land uses or activities that shall be permitted or excluded or subjected to special regulations.

The land development regulations and districts authorized by this Ordinance shall be made in accordance with a plan designed to promote and accomplish the objectives of this Ordinance. The Village of Leonard ordains:

ARTICLE I
SHORT TITLE

This Ordinance shall be known and may be cited as “The Village of Leonard Zoning Ordinance.”

Within the following text, it may be referred to as the “Ordinance.”

ARTICLE II

CONSTRUCTION OF LANGUAGE

For the purpose of this Ordinance, certain terms or words used herein shall be interpreted as follows, and the following rules of construction shall apply to the text of this Ordinance:

- a. The particular shall control the general.
- b. In the case of any difference of meaning or implication between the text of this Ordinance and any caption or illustration, the text shall control.
- c. The word “shall” is always mandatory and not discretionary. The word “may” is permissive and discretionary.
- d. Words used in the present tense shall include the future; and words used in the singular number shall include the plural, and the plural the singular, unless the context clearly indicates the contrary.
- e. A “building” or “structure” includes any part thereof.
- f. The phrase “used for” includes; “arranged for”, “designed for”, “intended for”, “maintained for”, or “occupied for”.
- g. The word “person” includes an individual, a corporation (public or private), a partnership, an organization, a public utility, firm, an incorporated association, or any other similar entity recognizable as a “person” under the laws of the State of Michigan.
- h. The word “erected” includes built, constructed, reconstructed, moved upon, or any physical operations on the premises required for the building. Excavations, fill, drainage, and the like shall be considered a part of erection.
- i. Unless the context clearly indicates the contrary, or a regulation involves two or more items, conditions, provisions, or events connected by the conjunction “and”, “or”, “either...or”, the conjunction shall be interpreted as follows:
 1. “And” indicates that all the connected items, conditions, provisions, or events shall apply.
 2. “Or” indicates that the connected items, conditions, provisions, or events may apply singly or in any combination.
 3. “Either....or” indicates that the connected items, conditions, or provisions, or events may apply singly or in any combination.
- j. Terms not herein defined shall have the meaning customarily assigned to them.

- k. Unless otherwise stated, the word “days” shall mean calendar days; “months” shall mean any consecutive period of 30 calendar days; and “year” shall mean any consecutive period of 365 calendar days.

ARTICLE III

DEFINITIONS

Section 3.01 – Definitions

For the purpose of this Ordinance, the terms and words herein are defined as follows:

ACCESS: A means to provide vehicular entrance to or exit from a lot.

ACCESSORY BUILDING: A subordinate building or structure (e.g. garage) on the same lot, not a part of the main building, occupied by or devoted exclusively to an accessory use. A garage or utility area attached to a residence or connected to it by a common roof or covered breezeway is not considered to be an accessory building.

ACCESSORY USE: A use naturally and normally incidental to, subordinate to, customarily found in connection with and auxiliary to the principal use of a lot and located on the same lot with such principal use.

ACT: Shall mean Public Act 110 of 2006, as amended, being the Michigan Zoning Enabling Act, MCL 125.3101, et seq.

ADULT REGULATED USES, DEFINITIONS: As used in this Ordinance, the following definitions shall apply to adult-regulated uses:

- a. **Adult Book Store:** An establishment having as a substantial or significant portion of its stock in trade, books, magazines and other periodicals and/or photographs, drawings, slides, films, video activities, video tapes, recorded tapes, and novelty items which are distinguished or relating to “specified sexual activities” or “specified anatomical areas”, (as defined below), or an establishment with a segment or section devoted to the sale or display of such material. Such establishment or the segment or section devoted to the sale or display of such material in an establishment is customarily not open to the public generally, but only to one or more classes of the public, excluding any minor by reason of age.
- b. **Adult Mini Motion Picture Theater:** An enclosed building with a capacity for less than fifty (50) persons used commercially for presenting material distinguished or characterized by an emphasis on matter depicting, describing or relating to “specified sexual activities” or “specified anatomical areas”, (as defined below), for observation by patrons herein. Such establishment is customarily not open to the public generally, but only to one or more classes of the public, excluding any minor by reason of age.
- c. **Adult Motion Picture Theater:** An enclosed building with a capacity of fifty (50) or more persons used commercially for presenting material distinguished or characterized by an emphasis on matters depicting, describing or relating to “specified sexual activities” or “specified anatomical areas”, (as defined below), for observation by patrons

herein. Such establishment is customarily not open to the public generally, but only to one or more classes of the public, excluding any minor by reason of age.

- d. **Amusement Gallery:** A place where the public is permitted or invited to view live images, motion pictures, video or laser disc pictures, digital media or other products of image producing devices where the images displayed are distinguished or characterized by the depicting or describing of “specified sexual activities” or “specified anatomical areas.”
- e. **Cabaret:** An establishment which features any of the following: topless dancers and/or bottomless dancers, go-go dancers, strippers, males and/or females or similar entertainers or topless and/or bottomless waitresses or employees.
- f. **Massage Parlor:** A building, room, place, or establishment other than a regularly licensed hospital or dispensary where nonmedical and nonsurgical manipulative exercises are practiced on the human body for other than cosmetic or beautifying purposes with or without the use of mechanical or bathing devices by anyone not a physician, surgeon, or similarly registered status.
- g. **Modeling Studio:** An establishment which furnishes facilities to the public to sketch, draw, paint, sculpt, or take photographs of males and/or females with specified anatomical areas (as defined below) exposed or makes such models available for any other purpose.
- h. **Specified Anatomical Areas are defined as:**
 - 1. Less than completely and opaquely covered:
 - (a) Human genitals, pubic region.
 - (b) Buttocks.
 - (c) Female breasts below a point immediately above the top of the areola.
 - 2. Human male genitals in a discernibly turgid state, even if completely and opaquely covered.
- i. **Specified Sexual Activities are defined as:**
 - 1. Human genitals in a state of sexual stimulation or arousal.
 - 2. Acts of human masturbation, sexual intercourse, or sodomy.
 - 3. Fondling or other erotic touching of human genitals, pubic region, buttocks, or female breasts.

AGRICULTURE: The practice of cultivating the soil, producing crops, and the raising of field or tree-crops or animal husbandry as means of income.

ALLEY: A dedicated public way providing a secondary means of ingress to or egress from land or structures thereon, as designated upon the Zoning Map.

ALLOWABLE FUELS: See Article IV, Section 4.57.

ALTERATIONS: Any change, addition or modification in construction or type of occupancy; any change in the structural members of a building such as a wall, partitions, columns, beams, girders, any substantial changes in the roof or exterior walls, any change in the location of a building, any change in the number of off-street parking or loading area, or any change which may be referred to herein as “altered” or “reconstructed” or “change of use”.

AUTOMOBILE DEALERSHIP: A place where automobiles, vans, trucks, and similar vehicles are sold, and where service may be carried out for minor repair and servicing, and where bumping and painting is clearly accessory to the use.

AUTOMOBILE REPAIR GARAGE: A building or structure designed or used for engine or transmission building, rebuilding or reconditioning of motor vehicles; collision service such as body, frame or fender straightening and repair, overall painting, vehicle rust proofing and any related activities.

AUTOMOBILE SERVICE STATION: A building or structure designed or used for the retail sale or supply of fuels, lubricants, air, water and other operating commodities for motor vehicles, aircraft or boats, and convenience stores that sell at retail consumable goods and including the customary space and facilities for the installation of such commodities on or in such vehicles, and including space for facilities for the temporary storage of vehicles not over forty-eight (48) hours, minor repair, or servicing. Automotive Service Station shall not include bumping, painting, refinishing, major repairs and overhauling, steam cleaning, rust proofing, high-volume of motor vehicle washing, or sale of new and used: cars, trucks, motorcycles, or other land vehicle type or sale related to service station use.

AUTOMOBILE WASH ESTABLISHMENT: A building or portion thereof, the primary purpose of which is that of washing motor vehicles.

BANK: An establishment for the custody, loan, exchange, or issue of money, for the extension of credit, and for facilitating the transmission of funds by drafts or bills of exchange.

BASEMENT: That portion of a building wholly or partly below grade, but so constructed that the vertical distance from the average grade to the basement floor is greater than the vertical distance from the average grade to the basement ceiling. A basement shall not be included as a story for height measurement. (See Illustration 1 entitled “basement and story”.)

BED AND BREAKFAST INN: A dwelling in which overnight accommodations are provided or offered for transient guests for compensation, including provision for a morning meal only and for overnight guests only.

BEDROOM: A room in a dwelling unit for or intended to be used for sleeping purposes by human beings.

BERM: A mound or wall of earth, sand or other material shaped and improved with landscaping in such a fashion as to be utilized for visual and/or audible screening purposes.

BIKEWAY: Pedestrian or non-motorized vehicular circulation routes built according to the standards of the Village or other agency with right-of-way jurisdiction, as applicable.

BILLBOARD: Any sign, device, design, words, letters, number, or trademark which directs attention to a business, commodity, service, or entertainment conducted, sold or offered other than on the premises on which the sign is located.

BLOCK: A block is the property abutting one side of a street and lying between the two nearest intersecting streets or between the nearest such streets and un-subdivided acreage, lake, or between any of the foregoing and any other barrier to the continuity of development.

BOARD of ZONING APPEALS: The words “Board of Zoning Appeals” or “Board” shall mean the Board of Zoning Appeals of the Village of Leonard.

BOARDING HOUSE: A single-family dwelling, which provides eating or sleeping accommodations for more than one (1) person who is not a member of the resident family.

BREEZEWAY: A structure connecting the principal building or house on a lot with an accessory building (e.g., garage), and may, in addition to a roof, have enclosed side walls or screening, or be open except for roof supports.

BUILDABLE AREA: The buildable area of a lot is the space remaining after the minimum open space, setback, parking, septic system, or any other requirements of this Ordinance have been complied with.

BUILDING: An independent structure having a roof supported by columns or walls intended and/or used for shelter or enclosure of persons, animals, chattels, or property of any kind. When any portion thereof is completely separated from every other part by division walls from the ground up, and without openings, each portion of such buildings shall be deemed a separate building. This refers to both temporary and permanent structures and includes tents, sheds, garages, stables, greenhouses, or other accessory structures.

BUILDING, MAIN or PRINCIPAL: A building in which is conducted the principal use of the lot upon which it is situated.

BUILDING DEPARTMENT: The Village Clerk’s Office of the Village of Leonard.

BUILDING OFFICIAL: The Building Inspector/Official of the Village of Leonard or other authorized representative of the Building Department.

BUILDING PERMITS: A Building Permit is the written authority issued by the Building Official of the Village of Leonard permitting the construction, removal, repair, moving, alterations, or use of a building in conformity with the provisions of this Ordinance.

BUILDING SETBACK LINE: The line which pertains to and defines those minimum (building) setback lines which are established parallel to the front street or right-of-way line and within which setback area no part of a building shall project and be located, except as otherwise provided for by this Ordinance. Such line when adjacent to a building is normally formed by the junction of the outer surface of the building or enclosure wall with the finish grade or surface of the adjoining ground.

CAMPGROUND: A parcel or tract of land under the control of a person in which sites are offered for the use of the public or members of an organization, either free of charge or for a fee, for the establishment of temporary living quarters for five (5) or more recreational units.

CARETAKER LIVING QUARTERS: An independent residential dwelling unit designed for and occupied by no more than two (2) people, where at least one (1) is employed to look after goods, buildings, or property on the lot on which the living quarters is located.

CARPORT: A structure for the storage, principally for one (1) motor vehicle, at one time, having no public shop or service in connection therewith, and to be designated solely for the private use of the owner or occupant of the principal building on a lot, or his family, and differing from a private garage in that it is not completely enclosed.

CHILD CARE CENTER: A facility, other than a private residence, receiving one (1) or more preschool or school age children for care for periods less than twenty-four (24) hours a day, and where the parents or guardians are not immediately available to the child. Child Care Center or day care center includes a facility which provides care for not less than two (2) consecutive weeks, regardless of the number of hours of care per day. The facility may also be described as a day care center, day nursery, nursery school, parent cooperative preschool, play group, or drop in center.

CHANGE of USE: Any alteration, any expansion of floor area, off street parking area, outdoor storage, service or operational area; land or water occupancy by a different permitted use; land or water occupancy by the same permitted use if a building or site has been unoccupied for a period of six (6) months; the addition of a canopy for vehicles or display area; dredging, filling, excavating, grading or paving which results in an earth change of more than fifteen (15) cubic yards, except gardening or agriculture.

CLERK: The Clerk of the Village of Leonard.

CLINIC: A building or a group of buildings where human patients are admitted, but not lodged overnight, for examination and treatment by more than one (1) professional, such as a physician, dentist, or the like.

CLUB: An organization of persons for special purposes or for the promulgation of agriculture, sports, arts, science, literature, politics, or the like, but not for profit.

COMMERCIAL VEHICLE: A truck or motor vehicle with cab and chassis and with a stake, rack, body, dump body, wrecker body, tanker body or any other body, the mounted height of which exceeds the height of the cab roof more than eight (8) inches. Any truck or motor vehicle that has a commercial license plate and is designed to accommodate a body length in excess of

nine (9) feet. Commercial vehicles shall not include motor homes or recreational vehicles, but shall include construction equipment such as backhoes, power shovels, bulldozers, earth moving equipment, semi-trucks, tractors, and trailers.

CONDOMINIUM: A condominium is a system of separate ownership of individual units in multi-unit projects. In addition to the interest acquired in a particular unit, each unit owner is also a tenant in common in the underlying fee and in the spaces and building parts used in common by all the unit owners. For the purposes of this Ordinance, condominium terms shall be defined as follows:

- a. **Condominium Act:** Shall mean Public Act 59 of 1978, as amended.
- b. **Condominium Lot:** The portion of a site condominium project designed and intended to function similar to a platted subdivision lot for purpose of determining minimum yard setback requirements and other requirements set for in Section 18.01 - Schedule of Regulations.
- c. **Condominium Project:** A plan or project consisting of not less than 2 condominium units established in conformance with the Michigan Condominium Act, Public Act 59 of 1978.
- d. **Condominium Unit:** That portion of the condominium project designed and intended for separate ownership and use, as described in the master deed for the condominium project.
- e. **Common Elements:** Portion of the condominium project other than the condominium units.
- f. **General Common Elements:** Common elements other than the limited common elements intended for the common use of all co-owners.
- g. **Limited Common Elements:** Portion of the common elements reserved in the master deed for the exclusive uses of less than all co-owners.
- h. **Master Deed:** A condominium document recording the condominium project to which are attached as exhibits and incorporated by reference the bylaws for the project and the condominium subdivision plan
- i. **Site Condominium Project:** A condominium project designed to function in a similar manner, or as an alternative to platted subdivision. A residential site condominium project shall be considered as equivalent to platted subdivision for purposes of regulation in the Ordinance.

CONVALESCENT or NURSING HOME: A convalescent home or nursing home is a licensed facility for the care of the aged, impaired, and persons suffering from permanent and/or extended physical disorders and illness, wherein two (2) or more persons receive care.

COUNTY: County of Oakland.

CUBIC CONTENT: The actual space enclosed within the outer surfaces of the outside walls and contained between the outside of roof and bottom of first floor joist or floor slab. Bays, oriels, and dormers are to be taken in full volume. Cubic content shall not include private garages, either attached or detached, parapets, outside steps, terraces, porches, breezeways, light shafts, cornices, footings, piles, caissons, deep foundations, exterior garden walls, outside stairways, fire escapes, fire towers, platforms, balconies, other projections, accessory buildings, or any non-habitable rooms or areas, or any part of a building which is below grade.

DENSITY: The number of dwelling units permitted by this Ordinance on an area of land.

DRIVE-IN ESTABLISHMENT: A business establishment so developed that its principal retail or service character provides a driveway approach or parking spaces for motor vehicles so as to serve patrons while in the motor vehicle (e.g., restaurants, cleaners, banks, theaters).

DRIVE-UP SERVICE: A business activity so developed that its retail or service character is dependent on providing a driveway approach and waiting spaces for motor vehicles so as to serve patrons while in the motor vehicle rather than within a building or structure.

DUMPSTER: A container used for the temporary storage of rubbish, pending collection, having a capacity of at least two (2) cubic yards.

DWELLING UNIT: A dwelling unit is any house, building, or portion thereof having cooking facilities, which is occupied wholly as the home, residence, or sleeping place of one (1) family, either permanently or transiently, but in no case shall an automobile chassis, tent or portable building be considered a dwelling. In case of mixed occupancy, where a building is occupied in part as a dwelling unit, the part so occupied shall be deemed a dwelling unit for the purpose of this Ordinance and shall comply with the provisions thereof relative to dwellings. Garage space, attached or detached, shall not be deemed a part of a dwelling for area requirements.

DWELLING, MULTIPLE FAMILY: A multiple dwelling is a building used as a residence for two (2) or more families living independently of each other and each having their own cooking facilities therein, including apartment houses, townhouses, and apartment hotels, but not including mobile home parks.

DWELLING, SINGLE FAMILY: A detached building containing not more than one dwelling unit designed for residential use of one (1) family only.

DWELLING, ROW, TERRACE or TOWNHOUSE: A row of three (3) or more attached single-family dwellings, not more than two and one-half (2½) stories in height, in which each dwelling has its own front entrance and rear entrance.

DWELLING, TWO-FAMILY: A detached two-family dwelling occupied by two (2) families, each provided with separate facilities for each family for living accommodations; also known as a duplex dwelling.

EFFICIENCY UNIT: An efficiency unit is a dwelling unit consisting of one (1) room, exclusive of bathroom, kitchen, hallway, closets, or dining alcove directly off the principal room providing not less than three hundred and fifty (350) square feet of floor area.

ESSENTIAL SERVICES: The erection, construction, alteration, or maintenance by public utilities or municipal departments or commissions of underground, surface, or overhead gas, electrical, fuel, steam, or water transmission or distribution systems, collection, communication, supply or disposal systems, including mains, drains, sewers, pipes, conduits, wires, cables, fire alarm boxes, traffic signals, hydrants, towers, poles, and other similar equipment, and accessories in connection therewith, as shall be reasonably necessary for the furnishing of adequate service by such public utilities or municipal departments or commissions or for the public health or safety or general welfare, but not including building.

FAMILY: One or more persons related by blood, adoption, or marriage, living and cooking together as a single non-profit housekeeping unit, inclusive of household servants. A number of persons living and cooking together as a single non-profit housekeeping unit having a continuing non-transient domestic character though not related by blood, adoption, or marriage, shall be deemed to constitute a family. This definition should not include any society, club, fraternity, sorority, group of students, association, lodge, combine, federation, group, coterie, or organization which is not a recognized religious order, nor include a group of individuals whose association is temporary and resort/seasonal or similar to a boarding house, motel or hotel, or for an anticipated limited duration of a school term or terms on a similar determinable period.

FAMILY CHILD CARE HOME: Shall mean that term as defined in Section 1 of 1973 Public Act 116, MCL 722.111, and only apply to the bona fide private residence of the operator of the family child care home.

FENCE: An unroofed man-made structure designed as a barrier. It may be made of wood, metal or any other material. It may be ornamental or intended for or capable of: enclosing a piece of land, preventing ingress and egress, dividing, bounding or simply marking a line.

FILLING: The depositing or dumping of any matter onto, or into the ground, except common household gardening and general farm care.

FLOOR AREA, GROSS: The sum of the gross horizontal areas of the several floors of the building measured from the exterior faces of the exterior walls or from the center line of walls separating two (2) buildings. The “floor area” of a building shall include the basement floor area when more than one-half (½) of the basement height is above the established curb level or finished lot grade, whichever is higher (see definition for Basement). Any space devoted to off-street parking or loading shall not be included in “floor area”. Areas of basements, utility rooms, breezeways, unfinished attics, porches (enclosed or unenclosed) or attached garages are not included. (See illustration 5 entitled “floor area terminology”.)

FLOOR AREA, USABLE: The measurement of usable floor area shall include that portion of the floor area, measured from the interior face of the exterior walls, used for or intended to be used for services to the public or customers, patrons, clients, or patients; including areas occupied by fixture or equipment used for display or sale of goods or merchandise, excluding kitchens, utility or mechanical equipment rooms, sanitary facilities, or strictly storage rooms. In the case of a half-story, the usable floor area shall be considered to be only that portion having a clear height above it of five (5) feet or more.

FOSTER CARE FACILITY: Shall be further defined as one of the following:

- a. **Large Group Home:** An adult foster care facility with the approved capacity to receive at least thirteen (13) but not more than twenty (20) adults who shall be provided with foster care. Beginning four (4) years after the effective date of Act 218, Public Acts 1979 (approved January 16, 1980), an Adult Foster Care Large Group Home which is licensed by the Department of Health to provide foster care in each respective category may receive only those adults in the category whose primary need for services is based upon not more than one (1) of the following categories:
 1. Aged condition.
 2. Mental illness, developmental disability, or physical handicap, or a combination of mental illness, disability, or physical handicap.
- b. **Small Group Home:** An adult foster care facility with the approved capacity of not more than twelve (12) adults who shall be provided with foster care.

GARAGE, COMMERCIAL: Any premises, except private residential accessory garages or community garages, available to the public, used principally for the storage of automobiles or motor driven vehicles, for remuneration, hire or sale, where any such vehicle or engine may also be equipped for operation, repaired, rebuilt or reconstructed, or where vehicles may be greased, washed, or serviced.

GARAGE, COMMUNITY: A community garage is a space, structure, or series of structures for the storage of motor vehicles having no public repair, shop, or service operated in connection therewith, for the use of two (2) or more owners or occupants of property in the vicinity.

GARAGE, PRIVATE: A portion of a main residential building designated or used solely for the storage of motor driven vehicles, boats and similar vehicles owned and operated by the occupants, and miscellaneous items generally associated with a residential occupancy.

GARBAGE: The word “garbage” shall be held to include every refuse, accumulation of all waste, animal, fish, fowl, fruit or vegetable matter incident to the preparation, use, cooking, dealing in or storing of meat, fish, fowl, fruit and vegetable, including spoiled food, dead animals, animal manure and fowl manure.

GRADE: Grade is the average level of the finished surface of the ground at the exterior walls of the building or structure. The grade shall be determined by computing the average elevation of the ground at each exterior wall of the building and taking the average of said total averages. When the finished ground level slopes away from the exterior walls, grade shall be established by the lowest points within the area between a building and a point six (6) feet from the building or the lot line, whichever is less. (See illustration 6 entitled “grade”.)

GREENBELT: A landscaped area not less than twenty (20) feet wide which is intended to serve as buffer between residential and non-residential land uses and as beautification for land uses in other places.

GROUP CHILD CARE HOME: Shall mean that term as defined in Section 1 of 1973 Public Act 116, MCL 722.111, and only apply to the bona fide private residence of the operator of the group child care home.

HEIGHT, BUILDING: The vertical distance measured from the established grade to the highest point of the roof surface if a flat roof; to the deck line of mansard roofs; and to the mean height level between eaves and ridge of gable, studio, hip and gambrel roofs; and seventy-five percent (75%) of the height of an “A” frame. (See Illustration 3 entitled “building height requirements”.)

HOME OCCUPATION: Any occupation conducted within a dwelling unit and carried on by the inhabitants thereof, not involving employees other than members of the immediate family residing on the premises, which use is clearly incidental and secondary to the use of the dwelling for dwelling purposes, does not change the character thereof, and which does not endanger the health, safety, and welfare of any other persons residing in that area by reason of noise, noxious odors, unsanitary or unsightly conditions, fire hazards and the like, involved in or resulting from such occupations, professions or hobby.

HOSPITAL: An institution providing health services, primarily for in-patients and medical or surgical care of the sick or injured, including as an integral part of the institution, such related facilities as laboratories, outpatient departments, training facilities, central service facilities and staff offices and operating under license by the Michigan Department of Community Health.

HOTEL: A building occupied as a more or less temporary abiding place for individuals who are lodged with or without meals in rooms occupied singly for hire, in which provision is not made for cooking on any individual plan and in which there are more than ten (10) sleeping rooms.

JUNK: For the purpose of this Ordinance, the term “junk” shall mean unlicensed or inoperable motor vehicles or parts thereof, machinery, appliances, products, or merchandise with parts missing or scrap metals or other scrap materials that are damaged, deteriorated, or are in a condition which cannot be used for the purpose for which the product was intended.

JUNKYARD: The term “junkyard” includes automobile wrecking yards and salvage areas and include any area of more than two hundred (200) square feet for the storage, keeping or abandonment of junk, including scrap metals, other scrap materials or reclaimed materials, or for the dismantling, demolition or abandonment of automobiles or other vehicles or machinery or parts thereof, but does not include uses established entirely within enclosed buildings which are in conformance with all other provisions of this Ordinance.

KENNEL: Any lot on which dogs, cats, or other species of household pets are kept, either permanently or temporarily, or are kept for the purpose of breeding, boarding or selling.

LABORATORY: A place devoted for experimental, routine, or basic study such as testing and analytical operations and in which manufacturing of product or products, except prototypes, is not performed.

LIVESTOCK: Any of various bird or animal breeds, long ago domesticated by man so as to live and breed in a tame, docile, tractable condition useful to man, including horses, ponies, mules, donkeys, cattle, swine, sheep, goats, chickens, ducks, geese, and turkeys.

LOADING SPACE: An off-street space on the same lot, with a building or group of buildings, for temporary parking of a commercial vehicle, while loading and unloading merchandise or materials.

LOT: A parcel of land of sufficient size to meet minimum zoning requirements for use, coverage, and area and to provide such yards and other open spaces as are herein required. Such lot shall have frontage on a dedicated roadway or on a permitted private road as may be provided by appropriate Ordinance. Such lot may consist of:

1. A single lot of record; or
2. A portion of a lot of record; or
3. A combination of complete lots of record or portions thereof; or
4. A parcel of land described by metes and bounds.

Provided that in no case shall a division or combination of any residential lot or parcel be created which does not meet the requirements of this Ordinance, the Land Division Act or the Land Division Ordinance.

LOT AREA: The total horizontal area within the lot lines of a lot. For lots fronting or lying adjacent to private streets, lot area shall be interpreted to mean that area within lot lines separating the lot from the private street, and not the centerline of said street.

LOT, CORNER: A corner lot is a lot of which at least two (2) adjacent sides abut for their full length upon a street, provided that such two sides intersect at an angle of not more than one hundred thirty-five (135%) degrees. Where a lot is on a curve, if tangents through the extreme point of the street line of such lot make an interior angle of not more than one hundred thirty-five (135%) degrees, it is a corner lot. In the case of a corner lot with curved street line, the corner is that point on the street lot line nearest to the point of intersection of the tangents described above. (See Illustration 4 entitled “corner, interior and double frontage lots”.)

LOT COVERAGE: The part, or percent of the lot, occupied by buildings or structures, including accessory buildings or structures.

LOT, DEPTH: The depth of the lot is the mean horizontal distance from the center of the front street line to the center of the rear lot line.

LOT, DOUBLE FRONTAGE: A lot other than a corner lot having frontage on two (2) “more or less parallel” streets. In the case of a row of double frontage lots, one (1) street will be designated as the front street for all lots in the plat and in the request for the building permit. If there are existing buildings in the same block fronting on one or both of the streets, the required minimum front yard setback shall be observed on those streets where buildings presently front.

LOT, INTERIOR: An interior lot is a lot other than a corner lot with only one (1) lot line fronting on a street.

LOT LINES: Any line dividing one (1) lot from another or from the right-of-way, and thus constitutes property lines bounding a lot.

- a. **Front Lot Line:** In the case of an interior lot abutting on one (1) public or private street, the front lot line shall mean the line separating the lot from such street right-of-way. In the case of a corner or double frontage lot, the front lot line shall be that line separating said lot from the street, which is designated as the front street in the plat, condominium plan, and/or in the application for a building permit.
- b. **Rear Lot Line:** That lot line that is opposite and most distant from the front lot line of the lot. In the case of an irregular, triangular, or gore-shaped lot, a line not less than ten (10) feet in length entirely within the lot parallel to and at the maximum distance from the front lot line of the lot shall be considered to be the rear lot line for the purpose of determining depth of rear yard. In cases where none of these definitions are applicable, the Village shall designate the rear lot line.
- c. **Side Lot Line:** Any lot line not a front or rear lot line. A side lot line separating a lot from a street is a side lot line. A side lot line separating a lot from another lot or lots is an interior side lot line.

LOT of RECORD: A lot which actually exists in a subdivision plat or condominium plan as shown on the records of the County Register of Deeds, or a lot described by metes and bounds, the description of which has been so recorded in the Office of the Register of Deeds for Oakland County.

LOT, WIDTH: The horizontal distance between the side lot lines, measured at the two (2) points where the building line or setback line intersects the side lot lines.

MAJOR THOROUGHFARE: The rights-of-way of Forest Street or Elmwood Street.

MANUFACTURED HOUSING: A mobile home, residential building, modular home, dwelling unit, a dwelling room or rooms, or a building component, assembly, or system that is manufactured in a manner that all concealed parts or processes of manufacture cannot be inspected before installation at the building site without disassembly, damage, or destruction, which is either wholly or substantially manufactured at an off-site location, and the installation of which is to be wholly or partially on-site in accordance with the National Manufactured Housing Construction and Safety Standards Act of 1974, as amended, being 42 USC § 601, et seq.

MINI-WAREHOUSE: A building or group of buildings consisting of individual, small, self-contained units that are leased or owned for the storage of business and household goods or contractors supplies, commonly referred to as a self-storage facility.

MOBILE HOME: A moveable or portable dwelling constructed to be towed on its own chassis and designed for permanent year round living as a single-family dwelling and connected to

sanitary sewage, electrical power, and potable water utilities. Provided, however, that the term “mobile home” shall not include motor homes, campers, recreational vehicles (whether licensed or not as motor vehicles), or other transportable structures designed for temporary use and which are not designed primarily for permanent residence and connection to sanitary sewage, electrical power, and potable water utilities.

MOBILE HOME PARK: A parcel or tract of land under control of a person upon which three (3) or more mobile homes are located on a continual non-recreational basis and which is offered to the public for that purpose regardless of whether a charge is made therefore, together with any building, structure, enclosure, street, equipment or facility used or intended for use incident to the occupancy of a mobile home and which is not intended for use as a temporary trailer park.

MOBILE HOME SITE: A designated lot within a mobile home park for the exclusive use of occupants of a single mobile home.

MOBILE HOME SUBDIVISION: A subdivision designed and/or intended for the sale of lots for residential occupancy by mobile homes in accordance with standards established under Act No. 288 of Public Acts of Michigan of 1967, as amended.

MOTEL: A series of attached, semi-detached, or detached rental units which may or may not be independently accessible from the outside parking area, containing bedroom, bathroom and closet space and designed for and occupied primarily for transients. No kitchen or cooking facilities are to be provided without the approval of the Village, with the exception of units for use by the manager and/or caretaker.

MOTOR HOME: A motorized vehicular unit primarily designed for travel or recreational usage, which may also contain facilities for overnight lodging. This term does not apply to mobile homes.

NOISE: Any sound that annoys or disturbs humans or which causes or tends to cause an adverse psychological or physiological effect on humans.

- a. **A-Weighted Sound Level:** The sound pressure level in decibels as measured on a sound level meter using the A-weighting network. The level so read might be designated dB(A).
- b. **Day-Night Average Sound Level:** The 24-hour energy average of the A-weighted sound pressure level, with the levels during the period 10:00 pm to 7:00 am the following day increased by ten (10) dB(A) before averaging.
- c. **Emergency:** Any occurrence or set of circumstances involving actual or imminent physical trauma or property damage which demands immediate attention.
- d. **Impulsive Sound:** Sound of short duration, usually less than one (1) second, with an abrupt onset and rapid decay. Examples of sources of impulsive sound include explosions, drop forge impacts, and discharge of firearms.
- e. **Noise Disturbance:** Any sound which; (a) endangers or injures the safety or health of humans or animals, or (b) annoys or disturbs a reasonable person of normal sensitivities,

or (c) endangers or injures personal or real property. For the purpose of this Ordinance, a Noise Disturbance shall be further defined as any sound that exceeds the limits set forth in Table A (page 7-3), following, or other standards set forth in this Section.

- f. **Noise Sensitivity Zone:** An area, which contains noise-sensitive activities, such as but not limited to, operations of schools, libraries, places of worship, hospitals, and nursing homes.
- g. **Pure Tones:** Any sound which can be distinctly heard as a single pitch or a set of single pitches.
- h. **Sound:** An oscillation in pressure, particle displacement, particle velocity, or other physical parameter, in a medium with internal forces that causes compression and rarefaction of that medium.
- i. **Sound Level:** The weighted sound pressure level obtained by the use of a sound level meter and frequency weighing network (for the purpose of this ordinance an A-weighted network), as specified by the American National Standards Institute.
- j. **Vibration:** An oscillatory motion of solid bodies of deterministic or random nature described by displacement, velocity, or acceleration with respect to a given reference point.

NONCONFORMING USE or NONCONFORMING BUILDING:

- a. **Nonconforming Use:** A non-conforming use is a use which lawfully occupied a building or land at the effective date of this Ordinance or amendments thereto, and that does not conform to the use regulations of the zoning district in which it is located. (See Illustration 7 entitled “nonconforming use”.)
- b. **Nonconforming Building:** A non-conforming building is a building or portion thereof lawfully existing at the effective date of this Ordinance, or amendments thereto, and which does not conform to the provisions (e.g., setbacks, height, lot coverage, and parking) of this Ordinance in the zoning district in which it is located. (See Illustration 7 entitled “nonconforming use”.)

NURSERY, PLANT MATERIALS: A space, building or structure, or combination thereof, for the storage of live trees, shrubs, or plants offered for wholesale or retail sale including products used for gardening or landscaping

OCCUPIED: The word “Occupied” includes arranged, designed, built, altered, converted to, rented or leased, or intended to be occupied.

OFF-STREET PARKING LOT: A facility providing vehicular parking spaces, along with adequate drives and aisles for maneuvering, so as to provide access for entrance and exit for the parking of more than two (2) automobiles.

OFF-STREET PARKING SPACE: A space of one-hundred and eighty (180) square feet (9' x 20') for the parking of an automobile, exclusive of access drives and aisles thereto.

OPEN AIR BUSINESS USES: Business uses not conducted entirely within an enclosed building. Open air business uses shall include the following business uses:

- a. Retail sale of trees, shrubbery, plants, flowers, seed, topsoil, humus, fertilizer, trellises, lawn furniture, playground equipment, and other home garden supplies and equipment.
- b. Retail sale of fruits and vegetables.
- c. Tennis courts, archery courts, shuffleboard, horseshoe courts, miniature golf, golf driving range, children's amusement park and/or similar recreation uses.
- d. Bicycle, utility truck or trailer, motor vehicles, boats, or home equipment sale, rental or repair services.
- e. Outdoor display and sale of garages, swimming pools, motor homes, mobile homes, snowmobiles, farm implements, and similar products.

OUTDOOR LIGHTING: See Article XX.

OUTDOOR WOOD FIRED STOVE/FURNACE: See Article IV, Section 4.57.

PET: A dog, cat, canary, parakeet, parrot, gerbil, hamster, guinea pig, turtle, frog, lizard, salamander, newt, fish, or rabbit.

PLANNING COMMISSION: The Planning Commission of the Village of Leonard.

PORCH: A structure attached to the ground including a covered entrance to a building, which may be enclosed in part.

POULTRY: Any of various breeds of birds long ago domesticated by man so as to live and breed in a tame, docile, tractable condition useful to man for meat and eggs, including chickens, ducks, geese, guinea fowl, and turkeys, not including game fowl.

POINT of OBSERVATION: The determination of the percentage of openness to the free passage of air and light in fences, privacy screens, and walls should be made from a specific point of observation. The point of observation shall be a point ten (10) feet away from the structure, perpendicular to the vertical surface plane of the structure and as viewed from a height above grade, which is equal to fifty (50%) percent of the structure height.

PREMISES: A lot, combination of lots or parcels of property in the same ownership or control which are not divided by a public street, and which form a complete parcel of land for development purposes.

PRIVACY SCREEN: Any unroofed man-made vertical structure intended and used as a visual barrier designed to inhibit or prevent observation of an area, from a point or points off the lot,

and the vertical surface of which is less than fifty (50%) percent open to the free passage of air and light. (See above definition “Point of Observation”)

PLACE OF WORSHIP: A building wherein persons assemble regularly for religious worship, and is maintained and operated by an organized religious body, as well as those structures within a religious complex that, while ancillary to the central location of worship, support regular assembly for worship. Places of worship include, but are not limited to, temples, synagogues, mosques, and churches.

PROHIBITED FUELS: See Article IV, Section 4.57.

PUBLIC UTILITY: Any person, firm, municipal department, or board duly authorized to furnish or furnishing under Federal, State, or municipal regulations a service which is of public consequence and need. The principal distinctive characteristics of a public utility is that of a service to or readiness to serve an indefinite public (or portion of a public as such), which has a legal right to demand and receive its services or commodities. Services or commodities for the purpose of this Ordinance include gas, electricity, steam, water, sewage, transportation, telephone, internet, cable television, and microwave and mobile phone communications.

QUARRY: Any pit, excavation, or mining operation for the purpose of searching for or removing from the premises any earth, rock, sand, gravel, clay, stone, slate, marble, lime, peat, marl or other non-metallic mineral in excess of fifty (50) cubic yards in any calendar year, but shall not include an excavation preparatory to the construction of a structure or public highway.

RECREATIONAL VEHICLE: A boat, snowmobile, off-road vehicle, camper travel trailer, motor home, pick-up camper, trailer which is designed for private recreational or recreational travel use.

REFUSE: Any waste material, except human excreta, including, but not limited to, garbage, animal carcasses, and trash or household materials.

RESTAURANT: A restaurant is an establishment whose business is the sale of food and beverage to a customer in a ready-to-consume state, and whose method of operation is characteristic of a carry-out, drive-in, drive-through, fast food, a standard restaurant, or bar/lounge, or a combination thereof, as defined below:

- a. **Restaurant, Carryout:** A carry-out restaurant is a restaurant whose method of operation involves the sale of food, beverages, and/or frozen desserts in disposable or edible containers or wrappers in a ready-to-consume state for consumption off the premises.
- b. **Restaurant, Drive-In:** A drive-in restaurant is a restaurant whose method of operation involves delivery of prepared food so as to allow its consumption in a motor vehicle or elsewhere on the premises, but outside of an enclosed building.
- c. **Restaurant, Drive-Through:** A drive-through restaurant is a restaurant whose method of operation involves the delivery of the prepared food to the customer in a motor vehicle, typically through a drive-through window, for consumption off the premises.

- d. **Restaurant, Fast-Food:** A fast-food restaurant is a restaurant whose method of operation involves minimum waiting for delivery of ready-to-consume food to the customer at a counter or cafeteria line for consumption at the counter where it is being served or at tables, booths, or stands inside the structure and out, or for consumption off the premises, but not in a motor vehicle at the site.
- e. **Restaurant, Standard:** A standard restaurant is a restaurant whose method of operation involves either:
 - 1. The delivery of prepared food by waiters and waitresses to customers seated at tables within a completely enclosed building or in an approved outdoor seating area; or
 - 2. The prepared food is acquired by customers at a cafeteria line and is subsequently consumed by the customers at tables within a completely enclosed building or in an approved outdoor seating area.
- f. **Bar/Lounge:** A bar or lounge is a type of restaurant, whose primary operation provides for the dispensing of alcoholic beverages, although the sale of prepared food, or snacks may also be permitted. If a bar or lounge is a part of a larger dining facility, it shall be defined as that part of the structure so designated or operated.

ROADSIDE STANDS: A roadside stand is a temporary building, wagon, cart, vehicle, or appurtenance located and seasonally operated for the purpose of selling only produce raised or produced on the premises where situated. Its use shall not make into a commercial district land that would otherwise be non-commercial, nor shall its use be deemed a commercial activity. Such stand, if of a permanent character, shall not be more than one (1) story high, or larger than twenty (20) feet by twenty (20) feet, and must be set back from the nearest right-of-way line at least twenty-five (25) feet.

RUBBISH: The miscellaneous waste materials resulting from housekeeping, public, semi-public or mercantile enterprises, trades, manufacturing, and offices, including other waste matter such as slag, stone, broken concrete, fly ash, ashes, tin cans, glass, scrap metal, rubber, wood, building materials, paper, rags, chemicals, or any similar or related combinations thereof.

SATELLITE ANTENNA: An accessory structure which at its widest dimension is in excess of thirty-six (36) inches; an earth based station, the purpose of which is to receive signals from orbiting satellites or other extraterrestrial sources, together with other equipment related to such purposes.

SEPARATE OWNERSHIP: Ownership of a parcel of property wherein the owner does not own adjoining vacant property. Owner of a property may include dual, or multiple ownership by a partnership, corporation, or other group. Provided that the owner of any number of contiguous lots of record for the purpose of this Ordinance as he so elects, and in such case the outside perimeter of said group of lots of record shall constitute the front, rear, and side lot lines thereof.

SETBACK: The minimum horizontal distance required to exist between the front, rear, or side of a building, excluding steps or unenclosed entryways, and adjacent right of way lines, lot

lines, conservation easements, alley easements, or streets, whichever provides a greater distance between the building and point of measurement.

SIDEWALK: Pedestrian or non-motorized vehicular circulation routes built according to the standards of the Village.

SIGN: See Article XIX

STATE: State of Michigan.

STABLE, PUBLIC: Any other stable except a private stable.

STATE EQUALIZED VALUATION: The value shown on the Village assessment roll as equalized through the process of State and County equalization.

STATE LICENSED RESIDENTIAL FACILITY: A structure constructed for residential purposes that is licensed by the state under the adult foster care facility licensing act, pursuant to Michigan Public Act 218 of the Public Acts of 1979, MCL 400.701 to 400.737, or the Child Care Organizations Act, pursuant to Michigan Public Act 116 of the Public Acts of 1973, MCL 722.111 to 722.128, and provides residential services for six (6) or fewer persons under 24-hour supervision or care.

STORAGE: The act of storing; the state of being stored.

STORY: That portion of a building included between the upper surface of any floor and the upper surface of any floor above; or any portion of a building between the top most floor and the roof having a usable floor area to at least fifty (50%) percent of the usable floor area of the floor immediately below it. The first story shall be considered the lowest story of which the ceiling is more than four feet above the average contact ground level at the exterior walls of the building. (See Illustration 2 “basic structural terms”.)

- a. **Mezzanine:** A mezzanine shall be deemed a full story when it covers more than fifty (50%) percent of the story underneath said mezzanine, or, if the vertical distance from the floor next below it to the floor next above it is twenty-four (24) feet or more.
- b. **Basement:** For the purpose of this Ordinance, a basement or cellar shall be counted as a story if over fifty (50%) percent of its height is above the level from which the height of the building is measured.
- c. **Ground Story:** The ground story is the lowest story of a building, the floor of which is not more than twelve (12) inches below the elevation of the reference level.
- d. **Half Story:** The part of a building between a pitched roof and the upper most full story, said part having a floor area which does not exceed fifty (50%) percent or less than the floor area below it. (See Illustration 2 “basic structural terms”.)

STREET: A thoroughfare which affords traffic circulation and principal means of access to abutting property, including avenue, place, way, drive, lane, boulevard, highway, road and other

thoroughfare, except a driveway or alley. A public street is a street accepted and certified for maintenance by the Village of Leonard. A private street is any thoroughfare that has not been accepted as a public street by the Village of Leonard.

STREET FRONTAGE: The length of that portion of a lot, which is considered the front lot line as defined in this Ordinance.

STRUCTURE: Anything constructed or erected which requires permanent rather than mobile location on the ground or attachment to something having such location.

STRUCTURAL ALTERATIONS: Any change in the supporting members of a building or structure, such as load bearing walls, or partitions, column beams, girders, or any change in the width or number of exits, or any substantial change in the roof or exterior walls.

SUBSTANDARD LOT: Any lot of record that does not meet the requirements of this Ordinance for lot area or width.

SWIMMING POOLS: Any structure or container, either above or below grade, located in either part or wholly outside a permanent enclosed and roofed building, designed to hold water to a depth greater than twelve (12) inches when filled to capacity. Intended for immersion of the human body either for swimming, wading, or both. A pond created by the excavation of an earthen pit shall not be considered a swimming pool.

TEMPORARY BUILDING STRUCTURE or USE: A building, structure, or use permitted by the Board of Zoning Appeals to exist during periods of construction of a use for special events, or for other uses which have a limited duration, not to exceed six (6) months.

TENTS: Tents as used in this Ordinance shall mean a shelter of canvas or the like supported by poles and fastened by cords or pegs driven into the ground and shall not include those types of tents used solely for children's recreational purposes.

TOURIST HOME: A dwelling in which overnight accommodations are provided or offered for transient guests for compensation, without provision for meals.

TOXIC or HAZARDOUS MATERIALS: Waste or a combination of waste and other discarded materials including solid, liquid, semisolid, or contained gaseous material which because of its quality, concentration; physical, chemical, or infectious characteristics may cause or significantly contribute to an increase in mortality or increase in serious irreversible illness or serious incapacitation, but reversible illness, or pose a substantial present or potential hazard to human health or the environment if improperly treated, stored, transported, disposed of, or otherwise managed.

TRAVEL TRAILER: A portable vehicular unit primarily designed for travel and/or recreational usage, which may also contain facilities for overnight lodging but which does not exceed eight (8) feet in width or twenty-five (25) feet in length. This term also includes folding campers and truck mounted campers, but not mobile homes.

TREASURER: The Village Treasurer of the Village of Leonard.

USE: The purpose for which a lot or premises or a building thereon is designed, arranged, intended, or for which it is occupied, or maintained, let, or leased.

UTILITY ROOM: A utility room is a room in a dwelling not located in the basement, the use of which is primarily for storage or for housing a heating unit or for laundry purposes.

VARIANCE: A modification of the literal provisions of the Zoning Ordinance which is granted by the Zoning Board of Appeals when certain conditions are met.

VILLAGE: The Village of Leonard, Oakland County, Michigan.

VILLAGE COUNCIL or COUNCIL: The Village Council of the Village of Leonard.

VILLAGE ENGINEER: The Village Engineer of the Village of Leonard or his authorized representative.

VILLAGE PLANNING COMMISSION, PLANNING COMMISSION or COMMISSION: The Village of Leonard Planning Commission.

WALL, RETAINING: A structural mass, which is designed and used to resist lateral pressures of soil behind it, and is designed to be safely supported by soil beneath it.

WASTE: Discarded as worthless, defective, or of no use. Refuse and waste material.

WAREHOUSE: A large structure or building where goods may be stored before their export or distribution for sale.

WIND ENERGY SYSTEM: See Article IV, Section 4.59.

WIND TURBINE: See Article IV, Section 4.59.

WIRELESS TELECOMMUNICATIONS TOWERS: See Article XXI

YARD: An open space of width or depth on the same lot with a building or group of buildings, which open space lies between the nearest point of a building or group of buildings and the nearest lot line, and is unoccupied and unobstructed from the ground upward, except for overhanging eaves and gutters which project less than twenty-four (24) inches into a required yard. (See Illustration 8 entitled “yard requirements”.)

YARD, FRONT: A yard extending the full width of the lot, the depth of which is the minimum horizontal distance between the front lot line and the nearest point of the main building. (See Illustration 9 “yard terms”.)

YARD, REAR: A yard extending across the full width of the lot, the depth of which is the minimum horizontal distance between the rear lot line and the nearest point of the main building. (See Illustration 9 “yard terms”.)

YARD, SIDE: A yard between a main building or a structure and the side lot line, extending from the front yard to the rear yard. The width of the required side yard shall be measured

horizontally from the nearest point of the side lot line to the nearest point of the main building.
(See Illustration 9 “yard terms”.)

ZONING DISTRICT or DISTRICT: A portion of the Village within which, on a uniform basis, certain uses of land and building are permitted and within which certain regulations and requirements are established.

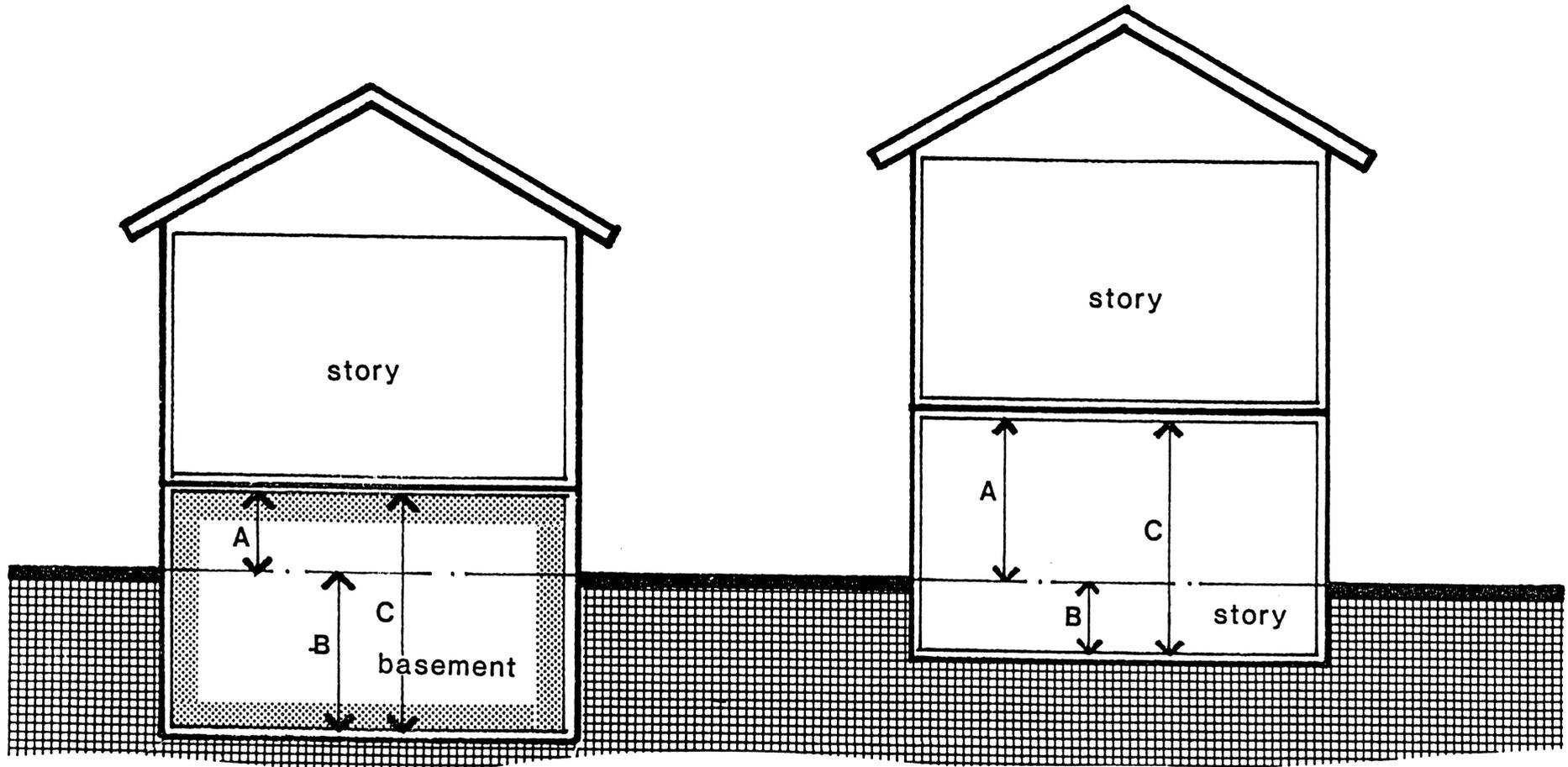

'A' less than 'B'
 'C' is basement

'A' greater than 'B'
 'C' is story

basement and story

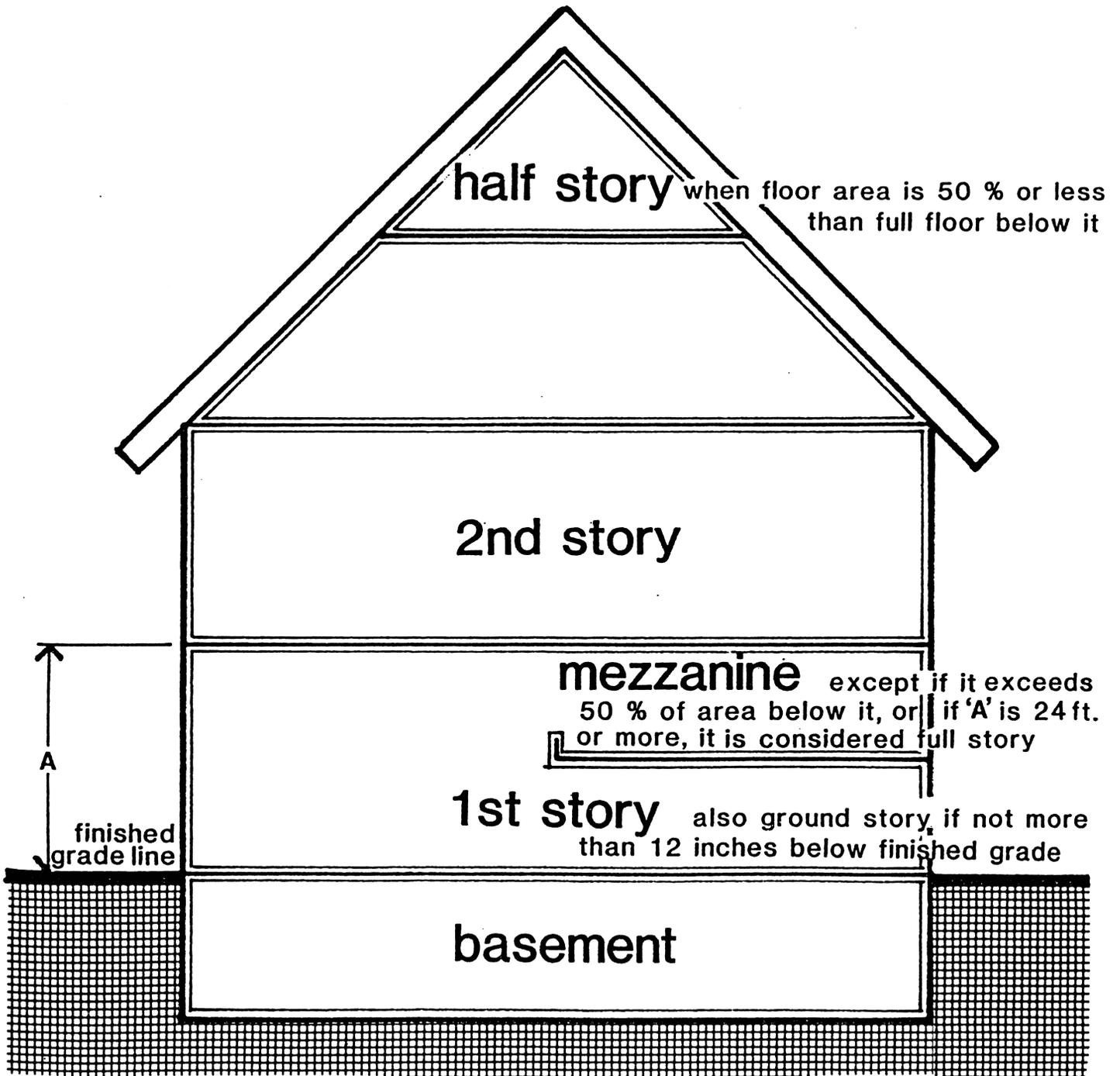

basic structural terms

Illustration 2

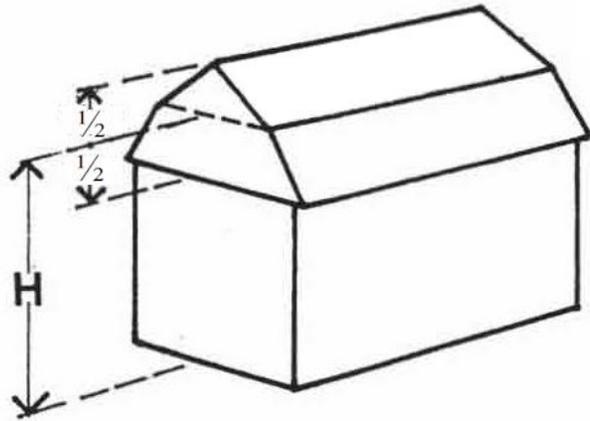

gambrel roof

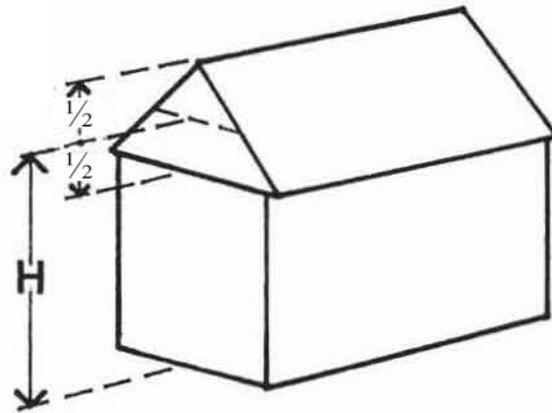

gable roof

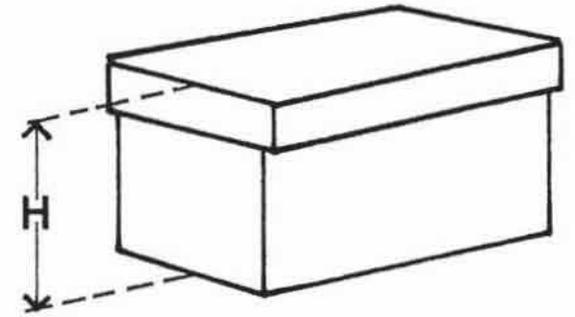

flat roof

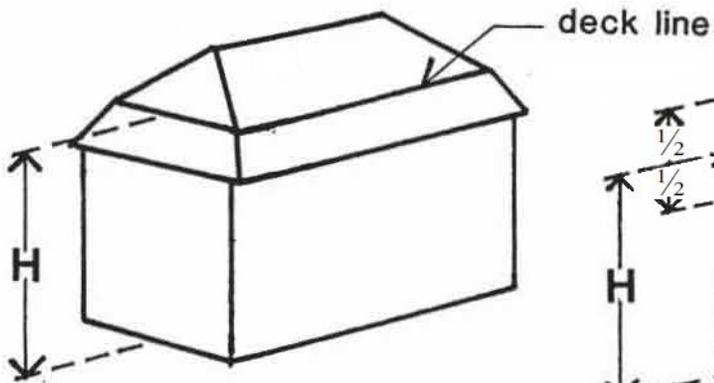

mansard roof

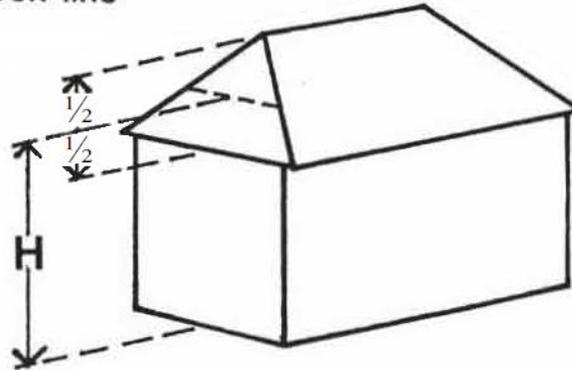

hip roof

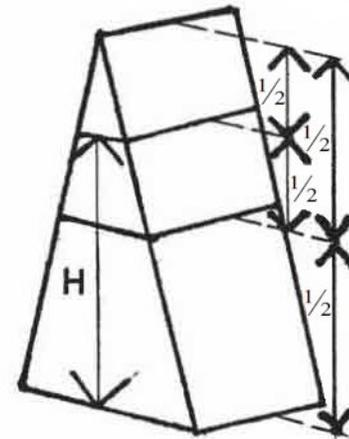

'A' frame

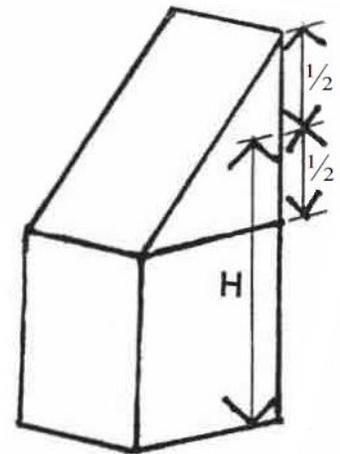

studio roof

Illustration 3

H: height of building

building height requirements

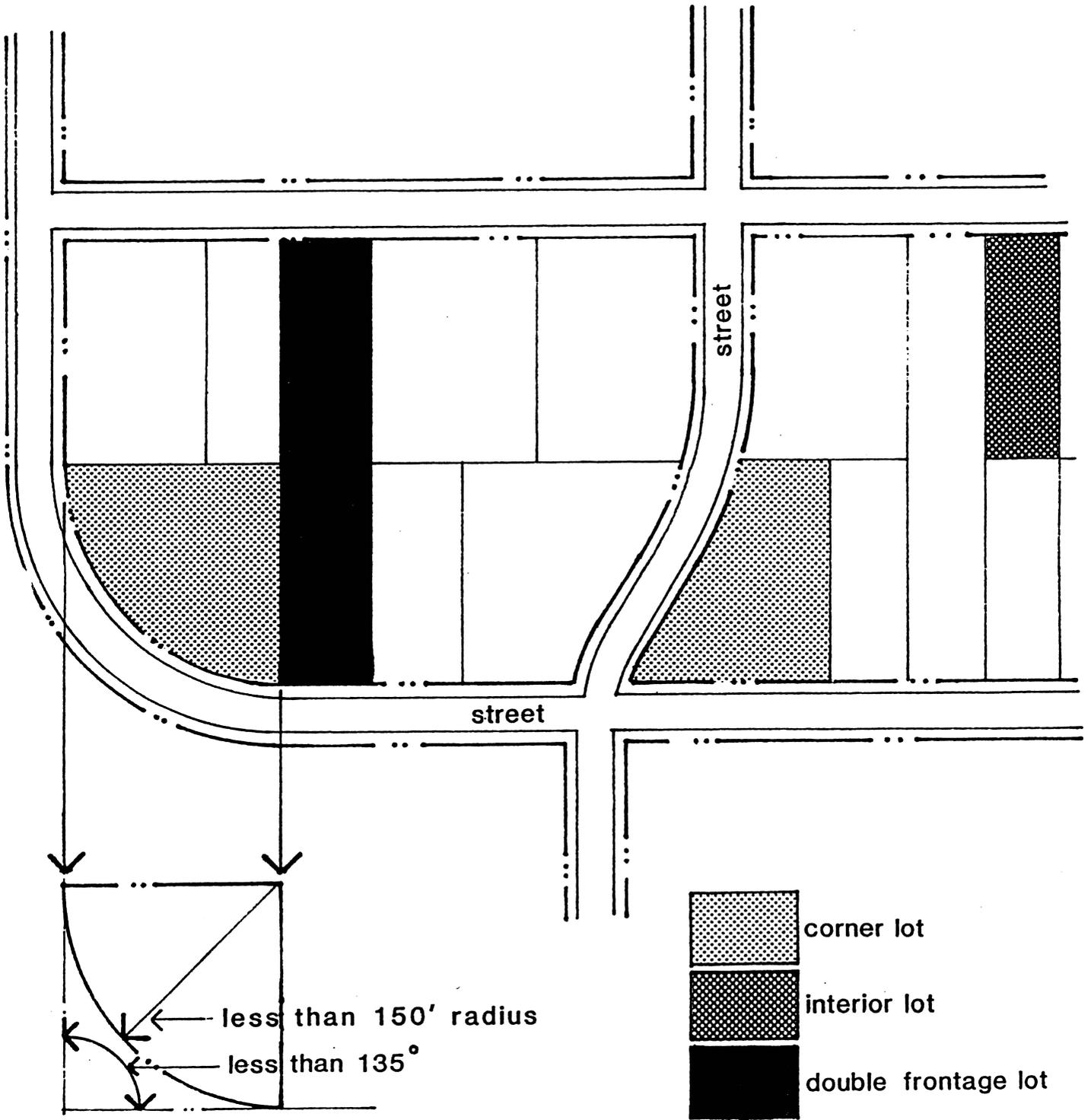

corner, interior & double frontage lots

Illustration 4

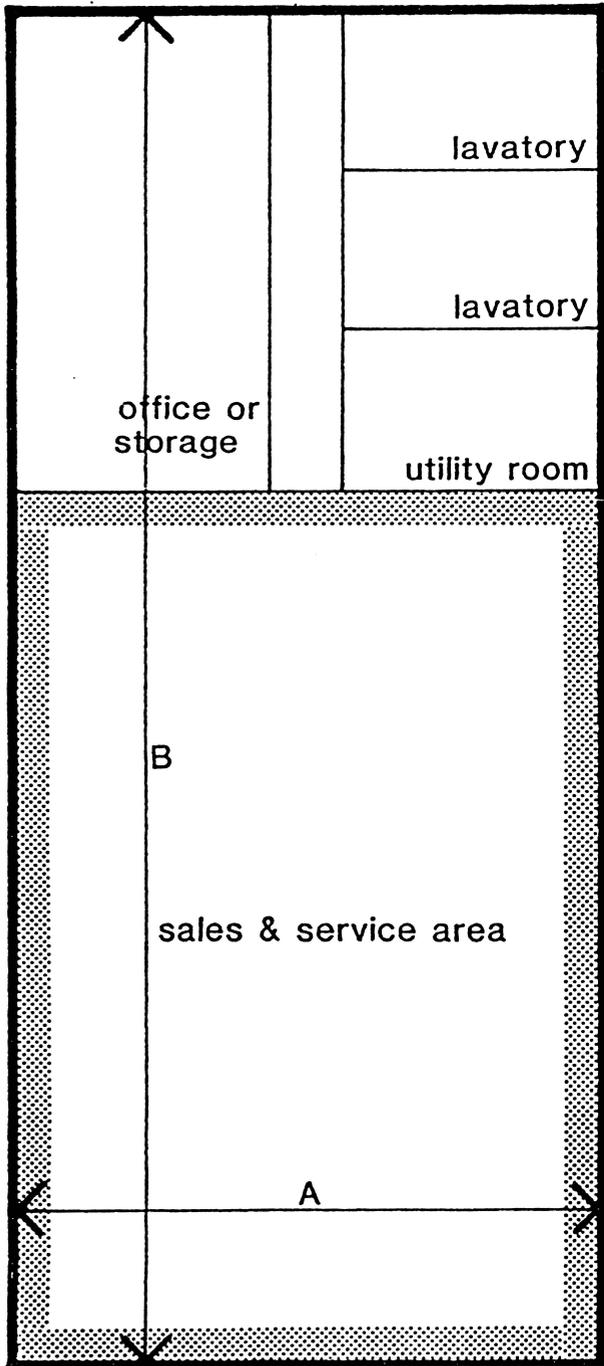

"A"X"B": GROSS FLOOR AREA



USABLE FLOOR AREA

floor area terminology

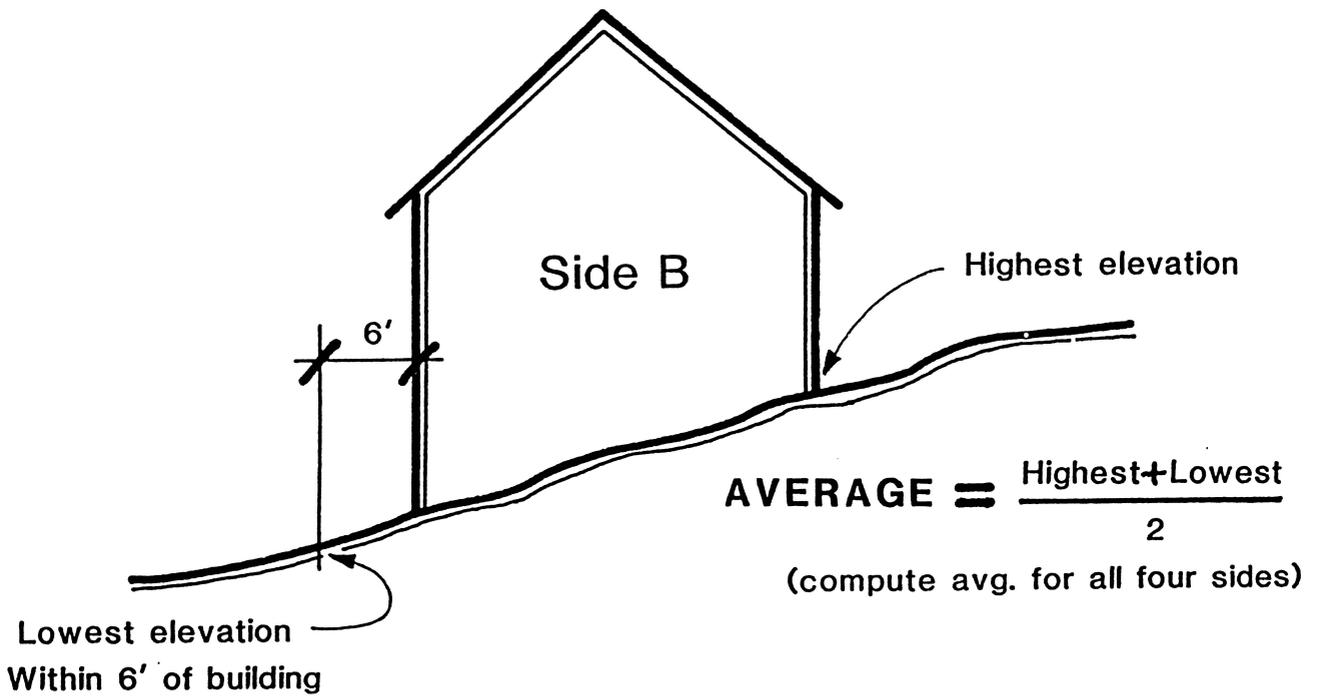
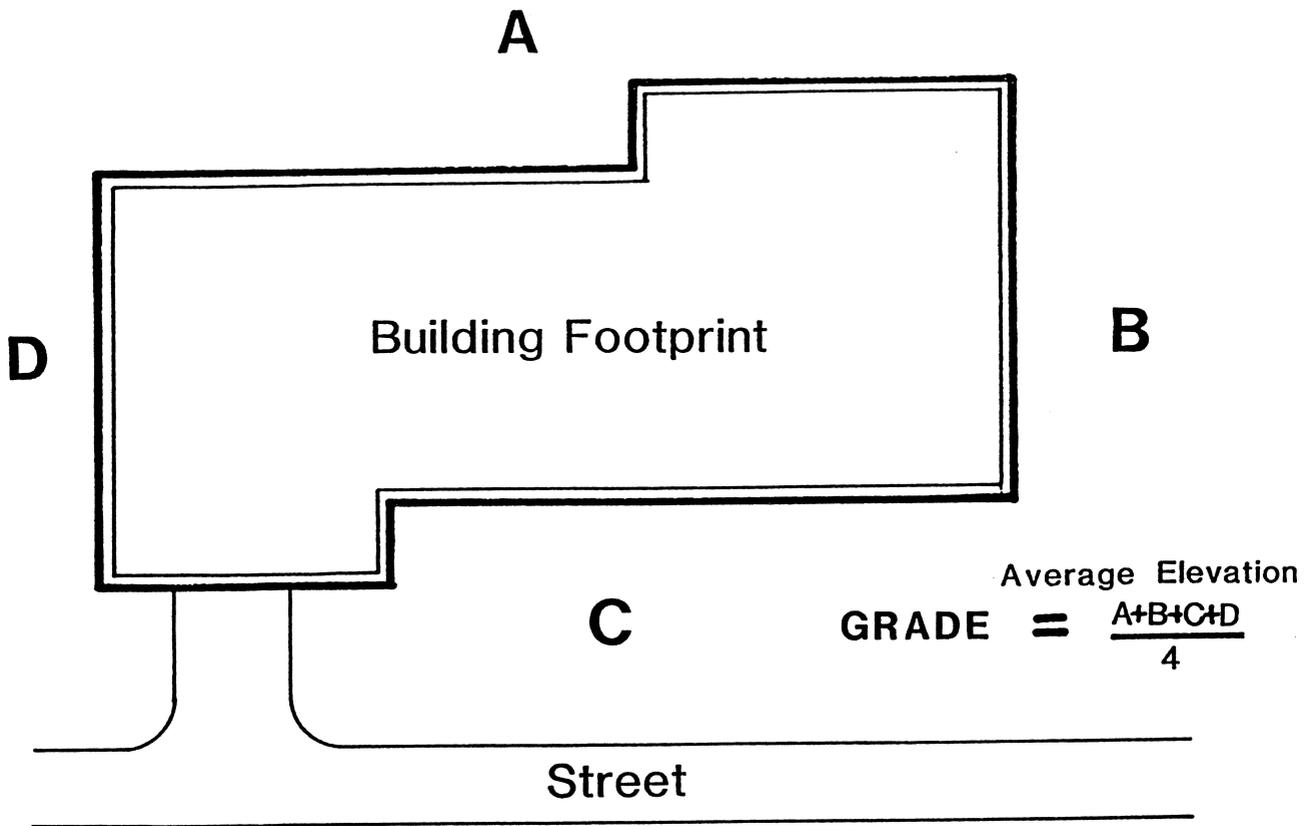

grade

Illustration 6

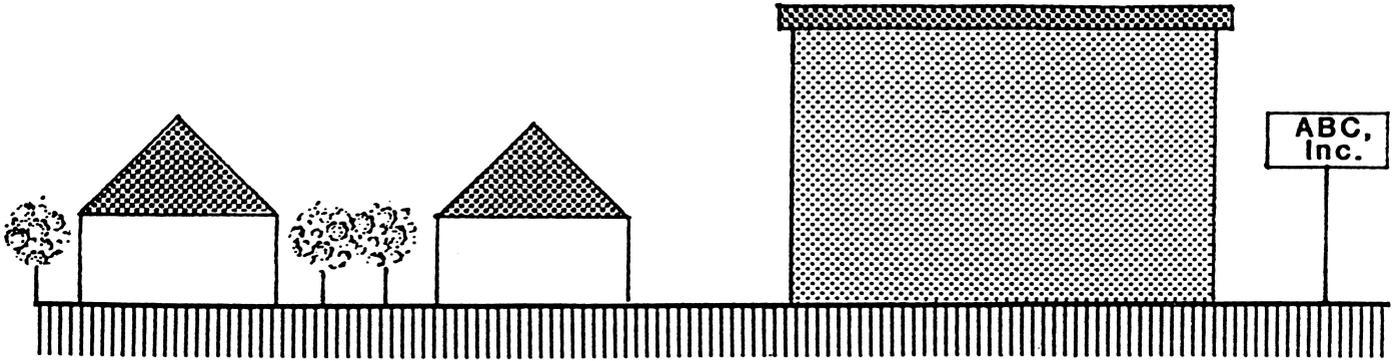

**Nonconforming Building and Use
(Industrial Plant in Residential District)**



**Nonconforming Use
(Residence Converted to Commercial Use in Residential District)**

nonconforming use

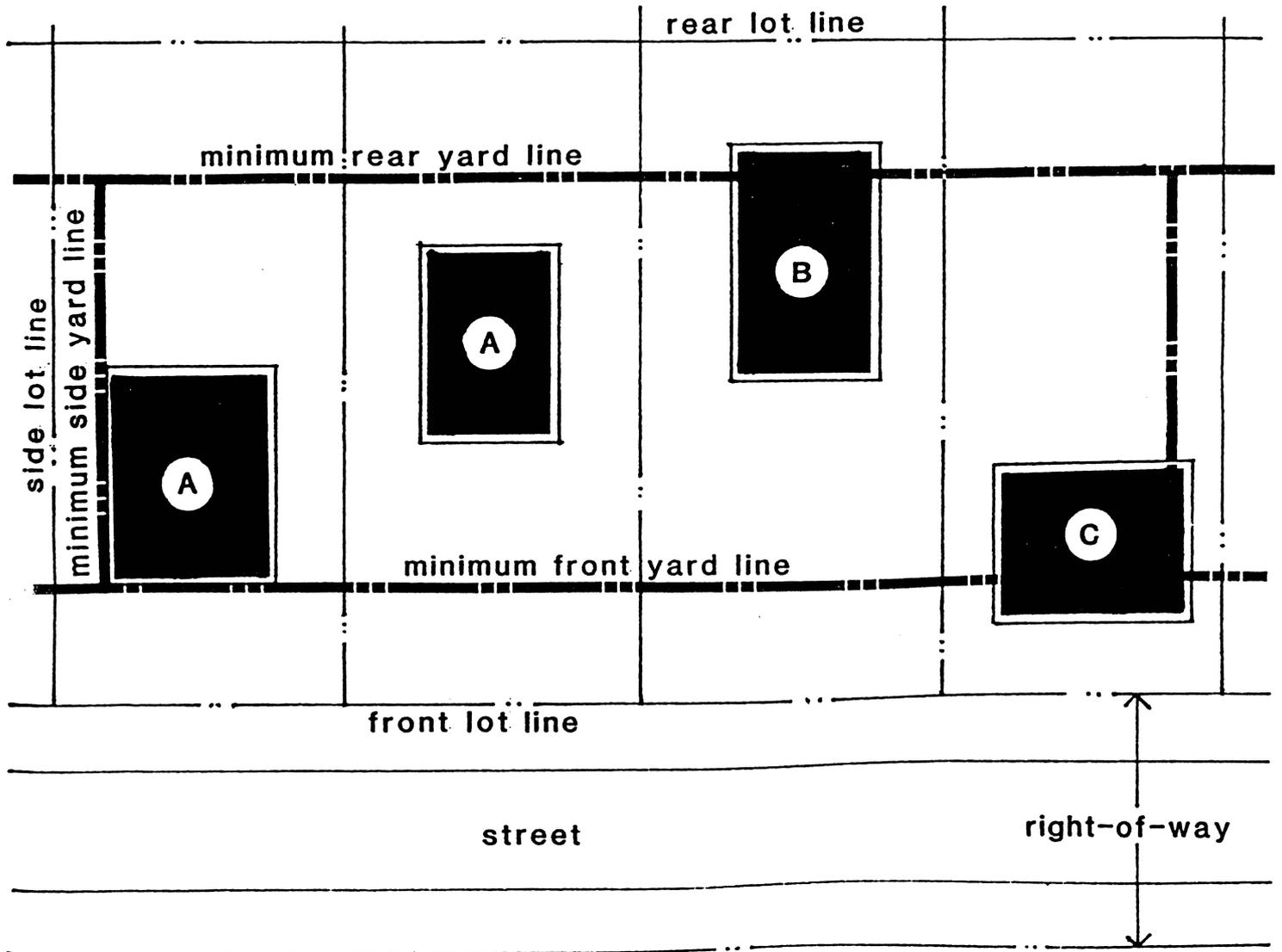

Legend

- A Structures satisfying minimum yard requirements.
- B Structure with deficient rear yard.
- C Structure with deficient front and side yards.

yard requirements

Illustration 8

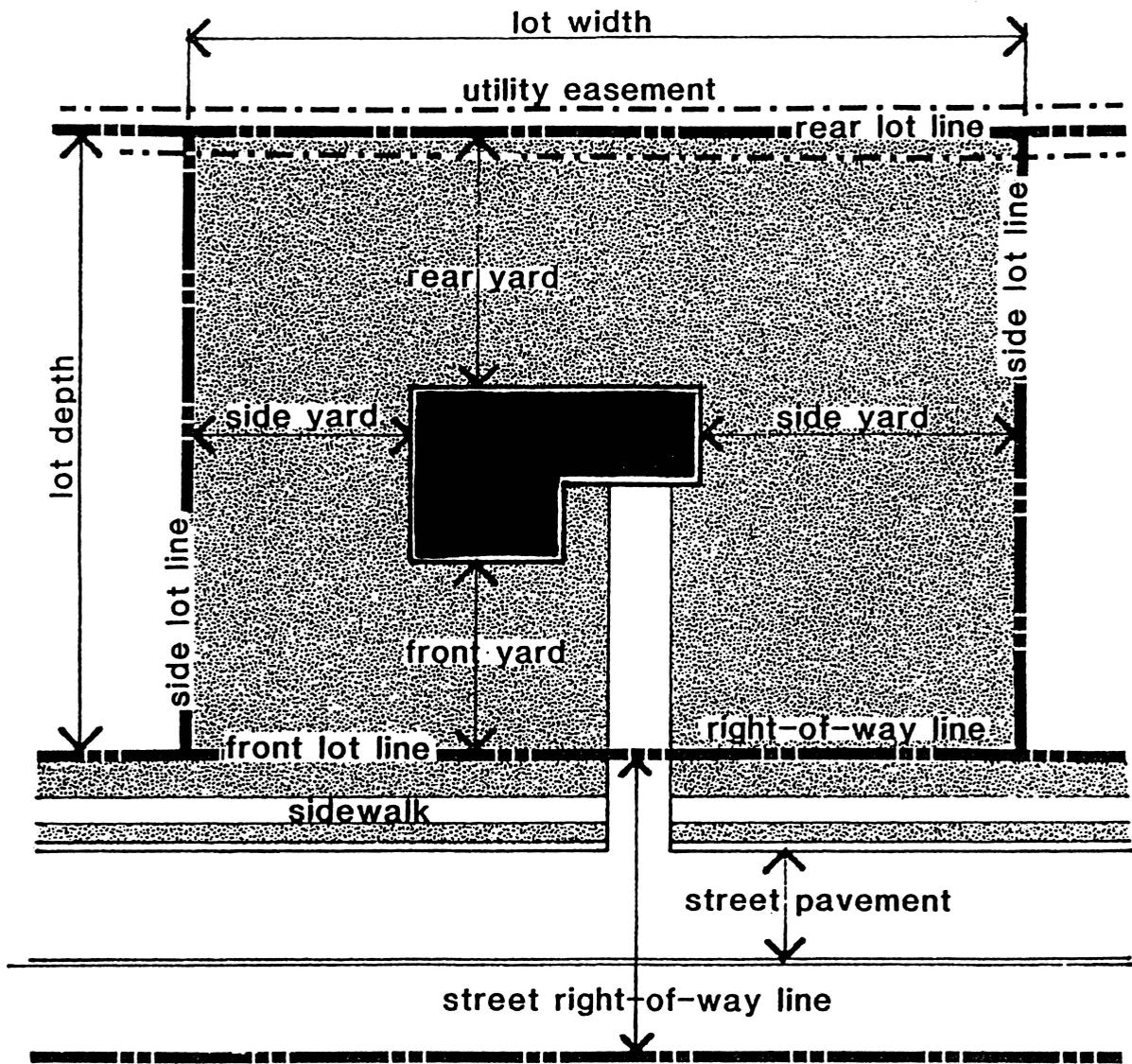

yard terms

ARTICLE IV

GENERAL PROVISIONS

Except as hereinafter specifically provided, the following general regulations shall apply:

Section 4.01 – Conflicting Regulations

Whenever any provision of this Ordinance imposes more stringent requirements, regulations, restrictions, or limitations than are imposed or required by the provisions of any other law or ordinance, the provisions of this Ordinance shall govern.

Section 4.02 – Scope

No building or structure, or part thereof, shall hereafter be erected, constructed, reconstructed or altered and maintained, and no new use or change shall be made or maintained of any building, structure or land or part thereof, except in conformity with the provisions of this Ordinance.

Section 4.03 – Street, Alley, and Railroad Right-of-Way

All streets, alleys, and railroad right-of-ways, if not otherwise specifically designated, shall be deemed to be in the same zone as the property immediately abutting upon such streets, alleys, and railroad rights-of-way. Where the centerline of a street or alley serves as a district boundary, the zoning of such street or alley, unless otherwise specifically designated, shall be deemed to be the same as that of the abutting property up to such centerline. Whenever any street, alley or other public way shall be vacated, such street, alley or other public way or portion thereof shall automatically be classified in the same district as the property to which it attaches.

Section 4.04 – Permitted Uses

No building shall be erected, converted, enlarged, reconstructed or structurally altered, nor shall any building or land be used, designed or arranged for any purpose other than is permitted in the district in which the building or land is located.

Section 4.05 – Permitted Area

No building shall be erected, converted, enlarged, reconstructed, or structurally altered, nor shall any open spaces surrounding any building be modified, except in conformity with the area, height, bulk, density, and setback regulations of the Zoning District in which the building is located.

Section 4.06 – Necessity of Continuing Compliance

No portion of a lot used in or necessary for compliance with the provisions of this Ordinance shall through sale or otherwise be reduced beyond this Ordinance's minimums or again be used to satisfy the zoning requirements of another lot or buildings.

Section 4.07 – Exceptions to Height Limitations

The height limitations of this Ordinance shall not apply to church spires, flag poles, public monuments, water towers, individual domestic radio and television aerials provided however, that the Planning Commission may specify a height limit for any such structure when such structure requires authorization as a Special Approval Use. Whenever such structures do not require Special Approval, their height shall be limited to a maximum of fifteen (15) feet above the height permitted for the principle use. Such structures shall not occupy more than twenty-five (25%) percent of the roof area of the building on which it is located. The height limitations of telecommunications towers shall comply with Article XXI – Wireless Telecommunication Towers and Antennas.

Section 4.08 – One Single-Family Dwelling Per Lot

Except in the instance of cluster developments or condominium developments for which a Site Plan is approved by the Village and except for lots used for education or religious institutions as may be expressly permitted under this Ordinance, not more than one (1) single-family dwelling shall be located on a lot as defined herein.

Section 4.09 – Reserved

Section 4.10 – Yard Encroachments

- a. Outside stairways, fire escapes, porches, platforms, balconies, boiler flues and other similar projections shall be considered as part of the building for purposes of determining yard, setback, and open space requirements.
- b. The above provision shall not apply to the following:
 1. One (1) fireplace or one (1) chimney, not more than eight (8) feet in length projecting up to twelve (12) inches into the required side yard.
 2. Cornices not exceeding eighteen (18) inches in width including the gutter.
 3. Platforms, terraces, steps below the first floor level.
 4. Unenclosed porches or ground level unenclosed projections not over one (1) story in height.

However, these projections shall not extend more than twelve (12) feet into the required front or rear yard and shall not extend nearer than four (4) feet from an interior side lot line or nearer than five (5) feet from a side lot line abutting upon a street. An unenclosed porch shall include porches with screens and/or removable storm window sashes.

- c. The minimum yard spaces, including minimum lot area per dwelling unit and maximum lot coverage required by this Ordinance for all buildings existing at the time of the passage of this Ordinance or for any building hereafter erected, shall not be encroached

upon or considered as yard or open space requirements for any other building. (See Article XVIII - Schedule of Regulations.)

Section 4.11 – Frontage

No dwelling or building shall be erected on a lot which does not have continuous frontage for its full required minimum width upon a street or road currently certified by the Village of Leonard.

Section 4.12 – Corner Lot Setbacks in Residential Districts

Every corner lot in any residential district which has on its side street an abutting interior residential lot shall have a minimum setback from the side street equal to the minimum front setback for the district in which such building is located; provided that this requirement shall not reduce the buildable width of any lot to less than thirty (30) feet.

Section 4.13 – Obstruction to Vision on Corner Lots

No structure, wall, fence, shrubbery, or trees shall be erected, maintained, or planted on any lot which will obstruct the view of a driver of a vehicle approaching an intersection, excepting that shrubbery, low retaining walls and fences not exceeding two and one-half (2½) feet in height above the curb level and trees where all branches are not less than eight (8) feet above the street level shall be permitted. In the case of corner lots, there shall be provided an unobstructed triangular area formed by the street property lines and a line connecting them at points formed by the two (2) street property lines and a line connecting them at points twenty-five (25) feet from the intersection of said street property lines.

Section 4.14 – Dwelling in Non-Residential Districts

No dwelling unit shall be erected in the C-1, or LI Districts except as may otherwise be permitted under the specific requirements of said Zoning Districts.

Section 4.15 – Occupancy of Garages, Accessory Buildings and Basement Apartments Prohibited

Buildings erected after the effective date of this Ordinance such as garages or accessory buildings shall not be occupied for dwelling purposes, nor shall any basement or cellar be used or occupied for dwelling purposes at any time except as permitted temporary use, subject to the provisions of this Article.

Section 4.16 – Accessory Buildings, Structures and Uses in Single Family Residential Districts

Accessory buildings, except otherwise permitted in this Ordinance shall be subject to the following regulations:

- a. Where the residential accessory building is structurally attached to a principal building, it shall be subject to and must conform to all building codes and regulations of this Ordinance applicable to main or principal buildings.
- b. No detached accessory buildings, structures, or uses shall be erected within the required front yard or within permanent easements. Structures less than one-hundred (100) square feet in area may be permitted within a required side yard.
- c. Accessory buildings or structures may occupy a portion of the required rear yard and shall be no nearer than ten (10) feet to any adjoining lot line and shall not exceed twenty (20) feet in height, except as otherwise provided herein.
- d. On corner lots where a rear yard abuts a side yard, accessory buildings on the corner lot shall have a minimum setback from the rear lot line a distance equal to the side yard setback required for the lot abutting the corner lot.
- e. An accessory building shall not occupy more than twenty-five (25%) percent of the required rear yard or forty (40%) percent of any non-required rear yard.
- f. No detached accessory building shall be located closer than ten (10) feet to any main or principal building.
- g. In the case of double frontage or corner lots, accessory buildings shall observe front yard setback requirements on both street frontages.
- h. In any residential zone, no private garages shall be erected closer to the side lot line than the permitted distance for the dwelling unless the garage shall be completely to the rear of the dwelling in which event the garage may be erected ten (10) feet from the side lot line. No garage or portion thereof shall extend into the required front yard area.

Section 4.17 – Accessory Buildings in Other than Single Family Residential Districts

- a. No accessory building or structure shall be erected in the front yard. In the case of lots with two (2) front yards, no accessory structure shall be located within the required minimum setback of either front yard.
- b. An accessory building, structure, or use must be in the same zoning district as the principal building, structure, or use to which it is an accessory.

Section 4.18 – Reserved

Section 4.19 – Grades

The grading of all building lots shall be such as to; (1) divert water away from buildings and (2) prevent standing water and soil saturation detrimental to structures and lot use and surrounding property.

- a. Any building requiring yard space shall be located at such an elevation that a sloping grade shall be maintained to cause the flow of surface water to run away from the walls of the structure thereon. The balance of yard spaces shall be graded and adequate drainage provided where necessary to deflect proper drainage of surface waters from the said premises. However, this shall not prevent the grading of a yard space to provide sunken or terraced areas, provided proper means are constructed and maintained to prevent the run-off of surface water from creating a nuisance on the adjacent properties.
- b. When a new building is constructed on a vacant lot between two existing buildings or adjacent to existing building, the existing established grade shall be used in determining the grade around the new building and the yard around the new building shall be graded in such a manner as to meet existing grades.

Section 4.20 – Dumpster or Outdoor Trash Receptacles and Fixtures

Outside dumpsters shall be permitted in all Zoning Districts, except in conjunction with single family residential uses, in compliance with the following requirements:

- a. Adequate vehicular access shall be provided to such containers for truck pick-up via either a public alley or vehicular access aisle, which does not conflict the use of off-street parking area, or entrances or exits to neighboring properties.
- b. A solid ornamental screening wall or fence shall be provided around all sides of dumpsters, which shall be provided with a gate for access and be of such height as to completely screen said containers. The maximum height of such enclosure shall not exceed six (6) feet. Dumpsters shall have an enclosing lid or cover.
- c. The rubbish container(s), the screening wall or fence and the surrounding ground area shall be maintained in a neat and orderly appearance, free from rubbish, waste paper or other debris. This maintenance will be the responsibility of the owner of the premises on which the containers are placed.
- d. There shall be compliance with all Village, County, and State Health Ordinances and Statues.
- e. No incinerator, garbage receptacle, oil or propane tank, or storage rack shall be exposed on the grounds outside any building without screening specified for rubbish containers and unless adequate safety and sanitary precautions are taken.

Section 4.21 – Storage of Obnoxious Matter in Open Containers Prohibited

No garbage, filth, refuse or other obnoxious matter shall be kept in open containers, piled or laid on the open ground; and all containers should be stored in such a way so as not be visible from any street. Notwithstanding, single family residential uses may compost yard debris created on that lot.

Section 4.22 – Use of Yard Spaces and Other Open Areas for Storage

There shall be no outside storage of more than one (1) unlicensed vehicle, which is required to be registered by law, permitted in any residential lot. This shall not be applicable to new or used car lots and junkyards. No machinery equipment, vehicles, lumber piles, crates, boxes, building blocks or other materials either discarded, unsightly or showing evidence of a need for repairs, with or without a current license, shall be stored, parked, abandoned or junked in any open area that is visible from the street, public place or adjoining residential property; and should such use of land occur, it shall be declared to be a nuisance.

Section 4.23 – Excavation or Holes

The construction, maintenance or existence within the Village of Leonard of any unprotected, un-barricaded, open, or dangerous excavations, holes, pits, or wells, which constitute a danger or menace to public health, safety, or welfare, are hereby prohibited. However, this Section shall not prevent any excavation under a permit issued by the Building Official, the County, or the state of Michigan where such excavations are properly protected and warning signs posted in such a manner as may be approved by the Building Official. This Section shall not apply to natural bodies of water or to ditches, streams, reservoirs, or other bodies of water created or existing by authority of the State of Michigan, County of Oakland, Village of Leonard, or other governmental agency.

Section 4.24 – Excavation, Removal and Filling of Land

The excavation, removal, filling or depositing of any type of garbage, rubbish or other wastes or by-products, is not permitted in any Zoning District except as provided for in a separate soil removal and landfill ordinance of the Village. Excavations, soil removal, or filling required for the installation or maintenance of septic systems, utilities, or pavement shall be permitted, subject to other applicable requirements of this Ordinance and other Village Codes and Ordinances.

Section 4.25 – Sewage Disposal

No human excreta or domestic, commercial, or industrial waste shall be deposited on the surface of the premises. Where a sewer system is available, all sanitary fixtures, such as water closets, lavatories, catch and slop sinks, laundry trays and bathtubs should be connected to such system. Where a sewer is not available, all facilities used in connection with the disposal of human excreta and water carried waste shall be connected with and the waste there from discharged into an approved private disposal system, the operation of which creates neither a nuisance nor pollutes a stream, lake or water supply. All sewage disposals shall be in compliance with the Oakland County Sanitary Code. No outside privies shall be permitted for new construction and/or any changes of occupancy; provided, however, that temporary use of outside privies shall be permitted during periods of construction pursuant to a valid Building Permit.

Section 4.26 – Government Functions

The Village of Leonard shall have the right to construct and maintain any building or structure required for the performance of its governmental or proprietary functions; provided that such building, structure or function shall conform to the use and procedural regulations including Site Plan Review of the Zoning District in which it is located, and of this Ordinance and be constructed so as to conform with the surrounding uses.

Section 4.27 – Voting Place

The provisions of this Ordinance shall not be so construed as to interfere with the temporary use of any property as a voting place in connection with a municipal or other public election.

Section 4.28 – Reserved

Section 4.29 – Easements

It shall be unlawful for any person to install, erect, cause, or permit the installation of a permanent structure on or across an easement of record which will prevent or interfere with the free right or opportunity to use or make accessible such easements for its proper use.

Section 4.30 – Regulations of Nuisance Activities

No activity or use shall be permitted on any property which by reason of the emission of odor, fumes, smoke, vibration, radiation, noise or disposal of waste is deleterious to other permitted activities in the zone district or is obnoxious or offensive to uses permitted in neighboring Zoning Districts, or is harmful to the general health, safety or welfare of the community.

Section 4.31 – Temporary and Portable Buildings, Uses, Structure and Special Events

The Zoning Board of Appeals may permit temporary buildings, structures, and uses for a period not to exceed six (6) months provided that all requirements and conditions relative to the type of structure and use, and timing and arrangements for termination and removal, are met. The Zoning Board of Appeals may require safeguards related to setbacks, screening off-street parking, and other factors considered necessary to protect the health, safety, welfare, and comfort of inhabitants of the Village. Further, the Zoning Board of Appeals may require Site Plan approval by the Village and performance guarantees as conditions of approval.

Mobile homes, mobile or temporary offices, trucks, truck trailers, vans or other passenger vehicles or trailers shall not be used for storage, warehousing, retail sales, service, or offices, except by approval of the Zoning Board of Appeals and subject to conditions imposed by the Zoning Board of Appeals.

No temporary building shall be erected in any residential Zoning District unless a Building Permit has been issued for a permanent building on the same site. Before a Certificate of Occupancy shall be issued, any temporary building shall be removed from the site.

Section 4.32 – Construction Begun Prior to Adoption of Ordinance

Nothing in this Ordinance shall be deemed to require any change in plans, construction or designed use of any building upon which actual construction was lawfully begun prior to the adoption of this Ordinance, and upon which building actual construction has been diligently carried on, and provided further, that such building shall be completed within one (1) year from the date of passage of this Ordinance.

Section 4.33 – Buildings to be Moved

Any building or structure which has been wholly or partially erected on any premises within or outside the Village of Leonard shall not be moved and/or placed upon any premises in the Village unless a building permit for such building or structure shall have been secured. Any such building or structures shall fully conform to all the provisions of this Ordinance in the same manner as a new building or structure.

Section 4.34 – Restoring Unsafe Buildings

Nothing in this Ordinance shall prevent the strengthening or restoring to a safe condition of any part of any building or structure declared unsafe by the Building Department.

Section 4.35 – Reserved

Section 4.36 – Keeping of Horses, Livestock and Other Animals

- a. Horses and other livestock may be kept on any lot with a minimum area of two (2) acres. The maximum number of animals allowed shall be in accordance with the following schedule:

LIVESTOCK TYPE	MAXIMUM ALLOWED
Horses or Ponies	Two (2) acres for the first horse and one (1) acre for each additional horse thereafter.
Cows	One (1) cow per two (2) acres. The combined number of cows and horses may not exceed one (1) animal per two (2) acres.
Pigs, Sheep, Goats	Two (2) per acre. If a combination of horses, cows, sheep, goats, and pigs are to be maintained two (2) sheep, goats, or pigs may replace either a cow or a horse in the total number allowed as indicated above.
Poultry	Thirty-five (35) per acre, in any combination, in addition to other livestock.

- b. All animals should be properly fenced and contained.
- c. Barns suitable for housing of animals and storage of the necessary hay and grain they consume may be constructed on the premises in accordance with this Ordinance. All barns and outbuildings shall require a building permit. When such buildings abut a

residentially zoned or occupied lot, barns and outbuildings shall conform to minimum setback requirements for principal residential buildings.

- d. Lots on which animals are kept shall be fenced. Special training or exercising corrals shall be located not less than one hundred (100) feet from any lot line.
- e. Except on farms, accumulations of manure shall be limited to a single designated area and shall be a minimum of one hundred-fifty (150) feet from all public right-of-ways, a minimum of one hundred (100) feet from side and rear lot lines, and a minimum of one hundred (100) feet from all dwellings. All manure and stable refuse shall be treated and handled in such a manner so as to control odor and flies and shall be screened from view off-site.
- f. Other animals that are not specifically permitted hereunder are prohibited except for pets and other animals permitted by the Zoning Board of Appeals and under conditions designed to protect the public health, safety, and welfare.

Section 4.37 – Fence, Wall, and Privacy Screen Regulations

Fences, walls, and privacy screens are permitted or required subject to the following:

- a. Fences in single family residential zoning districts shall not exceed six (6) feet in height above grade. Fences and screens on decks shall not exceed four (4) feet in height above the surface of the deck. Fences, which extend toward the front of lot farther than front of the house, shall not exceed four (4) feet in height above ground.
- b. Fences that enclose public or institutional playgrounds shall not exceed seven (7) feet in height above grade, and shall not obstruct vision to an extent greater than twenty-five (25%) percent of the total fence area.
- c. Fences shall not contain barbed wire, electric current, or charge of electricity, provided, however, that fences in non-residential districts which enclose storage area may have barbed wire connected therewith, provided such barbed wire is more than six (6) feet in height above grade.
- d. In single family residential zoning districts, privacy screens, as defined herein, shall be:
 - 1. Limited in height to no more than six (6) feet above ground; and
 - 2. Privacy screens shall be constructed so as to have an ornamental face toward the property line.

Section 4.38 – Protective Screening of Non-Residential Areas from Residential Areas

In order to provide adequate protective screening for residential areas adjacent to non-residential areas, the following regulations shall apply:

- a. Where a C-1 or LI District abuts directly upon a residential district, those districts shall be screened from such residentially zoned district by a solid, ornamental masonry wall five (5) feet in height above grade on the property line of the commercial or industrial use in the C-1 or LI District.
- b. A buffer strip of not less than ten (10) feet in width and fence may be permitted in lieu of the required wall upon a finding by the Planning Commission that the buffer strip or fence would provide equal or greater protection to the residential zoning district from any adverse effects from the use of the non-residential district.
- c. Where required walls are provided on the business side of public alleys, wall requirements may be waived or modified by the Planning Commission to provide clear vision and necessary entrance to or exit from required off-street parking and loading areas.

Section 4.39 – Wall, Brick, Facing

Whenever in this Ordinance a wall is required:

- a. The wall shall be un-pierced masonry wall, having a brick face on both sides with stone cap.
- b. Such wall shall be constructed prior to the back foundation or prior to any construction that extends above the foundation wall, whichever first occurs, in order to preserve the residential character and durability of the adjacent residential properties during the time of construction.

Section 4.40 – Exterior Lighting – See Article XX – Outdoor Lighting.

Section 4.41 – Reserved

Section 4.42 – Commercial Television, Telephone, and Radio Towers

Radio, telephone, and television towers and their attendant facilities may be permitted by the Planning Commission in AG Districts provided such use shall be located centrally on a continuous parcel of not less than ten (10) acres and shall have a dimension of not less than one and one-half (1½) times the height of the tower measured from the base of the tower to each property line. The Planning Commission shall not permit such towers without specific evidence that public safety will be protected.

Section 4.43 – Performance Guarantees

- a. To insure compliance with this Ordinance and any conditions imposed under this Ordinance, including conditions of Site Plan approval, cluster development approval, and variances, the Village Council, Planning Commission, or Zoning Board of Appeals may require that financial security acceptable to the Village be deposited with the Village Clerk to insure faithful completion of improvements as defined in b. below. The amount

of the cash deposit, certified check, or irrevocable bank letter of credit shall be in an amount equal to 125% of the estimated cost of improvements associated with a project and other reasonable incidental costs associated therewith, for which approval is sought.

- b. For purposes of this Section, “Improvements” means those factors and actions associated with a project which are considered necessary to protect natural resources or the health, safety and welfare of the residents of the Village and future users or inhabitants of the proposed project area, including roadways, lighting, utilities, landscaping, parking, paving of parking and circulation areas, screening, drainage and other site improvements. “Improvements” shall not include the entire project, which is the subject of the approval.
- c. The performance guarantee along with a detailed description and schedule of improvements to be completed shall be deposited with the Village Clerk prior to the issuance of a Certificate of Occupancy, whether temporary or permanent, authorizing use of the activity or project.
- d. The applicant shall be required to provide the performance guarantee or financial security in one or a combination of the following arrangements, whichever the applicant elects:
 - 1. An irrevocable letter of credit issued by a bank authorized to do business in Michigan in an amount equal to 125% of the estimated cost of the contemplated improvements as estimated by the Village; or
 - 2. A cash deposit, or deposit by certified check drawn on a bank authorized to do business in Michigan in an amount equal to 125% of the estimated cost of the contemplated improvements as estimated by the Village. The escrow deposit shall be for the estimated time period necessary to complete the required improvements.
- e. In the case of cash deposits, the Clerk shall rebate or release to the applicant, as the work progresses, amounts equal to the ratio of the completed and accepted work to the entire project, after approvals described below.
- f. Completion of improvements and acceptance for maintenance of required public improvements shall be in accordance with the following:
 - 1. The applicant shall furnish the Clerk a letter or document signed by the Building Official indicating satisfactory completion of the required improvements.
 - 2. After the completion of the construction of the required public improvements, the Village Engineer or Building Official, or the County, State or Federal agency with jurisdiction shall inspect and certify compliance with above improvements. This inspection shall be made to assure the improvements are completed according to the approved plans and specifications.
 - 3. In no case shall acceptance of any partial street be made for maintenance by the Village.

- g. In case the applicant shall fail to complete the required improvements within such time period as required by the conditions or guarantees as outlined above, the Village Council may proceed to have such work completed and reimburse itself for the cost thereof by appropriating the cash deposit or certified check, or by drawing upon the letter of credit.
- h. The Village may require, prior to the acceptance by the Village of public improvements, a maintenance bond acceptable to the Village for a period of up to three (3) years in an amount not to exceed thirty-five (35%) of the total cost of the public improvements.
- i. This Section shall not be applicable to improvements for which cash deposit, certified check, irrevocable bank letter of credit, or surety bond has been deposited pursuant to the Land Division Act, No. 288 of the Public Acts of 1967, as amended, being Section 560.101 to 560.293 of the Michigan Compiled Laws.

Section 4.44 – Commercial Vehicles in Residential Areas

- a. **Purpose:** The purpose of restrictions on commercial vehicles is to preserve the health, safety, and general welfare of persons and property in residential areas designed and utilized for single family residential development by regulating the parking of certain large commercial vehicles which frequently are impediments to the ingress and egress of emergency and fire protection vehicles and equipment, which are frequently unsafe when operated on residential streets, and the noise, exhaust emissions and appearance of which tend to impair the health, safety and general welfare of the people of the Village.
- b. **Residential Parking Prohibited:** In residential zones it shall be illegal to park or store more than one (1) commercial vehicle larger than a regularly manufactured pick-up or panel truck of one and one-half (1½) ton capacity per lot. The commercial vehicle must be owned and operated by a member of the family residing on said lot. Provided, however, this provision shall not apply to commercial vehicles temporarily parked in a residential area in conjunction with maintenance or service to a residential property.
- c. **Presumption of Ownership:** In any proceeding for violation of any parking provision of this Section, the person to whom the commercial vehicle is registered, as determined from the registration plate displayed on said motor vehicle, shall be presumed in evidence to be the person who committed the violation charged.

Section 4.45 – Adult–Regulated Uses

- a. **Intent and Rationale:** In the development and execution of this Ordinance and this Section, it is recognized that there are some uses which because of their very nature, are recognized as having serious objectionable, operations characteristics, particularly when several of them are concentrated under certain circumstances, thereby having deleterious effect upon adjacent areas. Special regulations of these uses are necessary to insure that these adverse effects will not contribute to the blighting, deteriorating, and/or down grading of the area, and that area adjacent thereto.

These special regulations are itemized in this Section. The Village believes that control or regulation is for the purpose of preventing a concentration of these uses in any one area.

It is further recognized in the development of this Ordinance that the prohibition against the establishment of more than one Adult Regulated Use within seven-hundred and fifty (750) feet of each other serves to avoid the clustering of a blighted or deteriorated area frequented by vagrants, and the like; such prohibition further serves to avoid the deleterious effects of blight and devaluation of both business and residential property values resulting from the establishment of Adult Regulated Uses immediately adjacent to residential neighborhoods; such prohibition further serves to prevent the deleterious effect of blight and devaluation of recreational, educational, and or religious uses.

It is further recognized in the development of this Ordinance and this Section that concern for, and pride in, the planning and development of this neighborhood and area should be encouraged and fostered in those persons who comprise the business and residential segments of that neighborhood and area.

b. **Itemization of “Adult Regulated Uses”:** Uses subject to the controls set forth in this Section shall be as follows, and are referred to herein as “Adult Regulated Uses”:

1. Adult Book Store
2. Adult Mini-Motion Picture Theatre
3. Adult Motion Picture Theatre
4. Amusement Gallery
5. Cabaret
6. Massage Parlor
7. Modeling Studio
8. Adult Content Video Sales and Rental Stores

c. **Prohibition:** Unless and until approval is first sought and obtained hereunder, it shall be unlawful to hereafter establish any Adult Regulated Use.

d. **Requirements:**

1. The Adult Regulated Use shall be located only in the C-1 District.
2. The structure of any regulated use shall be at least seven-hundred and fifty (750) feet away from the nearest property line of any public, private or parochial school, library, park, playground or other recreational facilities which admits minors, daycare centers, or nursery schools; and at least seven-hundred and fifty (750) feet from the nearest property line of any church, convent, monastery, synagogue, or other similar places of worship, except as provided below.
3. Application to establish any Adult Regulated Use shall not be approved if there is already in existence or a site plan approved and effective for one or more adult regulated use within seven-hundred and fifty (750) feet of the boundaries of the site of the proposed adult regulated use, except as provided below.

4. The measurement used to determine the application of any of the above restrictions shall be made from the nearest boundary line of the proposed Adult Regulated Use on a straight line to the nearest boundary line of the use in connection with which the measurement is being taken.

e. **Application and Review:**

1. Any person desiring to establish an Adult Regulated Use shall submit an application for Special Approval, in accordance with Article XXVI – Special Approval Procedures and Standards of this Ordinance, to the Village Clerk, who shall place the application on the Planning Commission agenda for formal receipt at the next regular meeting.
2. A date for the public hearing of the Planning Commission shall be conducted as soon as reasonably possible, and in any event shall not exceed forty-five (45) days from the filing of the application.
3. Notice of public hearing shall be published, mailed, and delivered in accordance with Article XXVI – Special Approval Procedures and Standards.

Special approval shall not be granted until a public hearing has been held by the Planning Commission, in accordance with the procedures described herein above. The Planning Commission shall make a written recommendation to the Village Council to deny, approve, or approve with conditions, requests for special approval use. The recommendation of a special approval use shall be incorporated in a statement of conclusions relative to the special approval use under consideration. The decision shall specify the basis for the decision, and any conditions.

4. The Village Council may approve the application if all of the following findings are made:
 - (a) All location requirements of this Section are met.
 - (b) The site layout and its relation to the streets giving access to it shall be such that vehicular and pedestrian traffic to and from the use or uses, and the assembly of persons in connection therewith, will not be clearly hazardous, endangered, or inconvenient to the neighborhood. In applying this standard, the Village shall consider, among other things: the relationship of the proposed use to convenient routes for pedestrian traffic, main vehicular traffic thoroughfares and to streets and road intersections and the general intensity of the existing and potential development of the neighborhood. The Village Council shall determine that the proposed use will not have a clear detrimental effect.
 - (c) The proposed use will not clearly cause a nuisance or harm the public health, safety and general welfare or an unreasonable diminution to the value of other property in the immediate area.

5. The Village Council may waive the location provision requiring minimum distance between Adult Regulated Uses and a public, private or parochial school, library, park, playground, or other recreational facility, which admits minors, day-care center or nursery school, church, convent, monastery, synagogue, or other similar place or worship, if all of the following findings are made after Public Hearing:
 - (a) That proposed use will not be contrary to the public interest or injurious to nearby properties, and that the spirit and intent of this Ordinance will be observed; and,
 - (b) That the proposed use will not contribute to, create, enlarge and/or encourage a blighted or deteriorated area; and,
 - (c) That the establishment of an additional Adult Regulated Use in the area will not be contrary to any program of neighborhood conservation, nor will it interfere with any program or urban renewal; and,
 - (d) That all applicable regulations of this Ordinance will be observed; and,
 - (e) There is no other reasonable location in the Village at which the use is suited.
6. **Discontinuance:** An Adult Regulated Use approved pursuant to the terms of this Ordinance may not be re-established after discontinuance for a period of ninety (90) consecutive days without a new grant of approval by the Village.

Section 4.46 – Home Occupations

Home occupations shall be permitted in all residential districts and provided further that:

- a. Such occupation shall not require internal or external alterations or construction features, equipment, machinery, outdoor storage. All signs shall conform to the standards for home occupations found in Article XIX - Signs.
- b. No home occupation shall generate other than normal residential traffic in either amount or type.
- c. Parking needs generated by a home occupation shall be provided for in an off-street parking area, located other than in a required front yard.
- d. All business activity shall be conducted within a dwelling unit.
- e. No equipment or process shall be used in such home occupation which creates noise, vibrating, glares, fumes, odors, or electrical interference detectable to the normal senses off the lot. In the case of electrical interference, no equipment or process shall be used which creates visual or audible interference in any radio or television receivers off the premises, or causes fluctuations in the line voltage off the premises.

- f. Day-care centers, tearooms, veterinarian office, tourist homes, animal hospitals, kennels, millinery shops, barbershops, and beauty shops, among others, shall not be deemed to be home occupations.

Section 4.47 – Reserved

Section 4.48 – Enclosure of Roof Appliances or Accessories

For all non-single family residential uses, roof appliances such as, but not limited to, cooling towers, air conditioners, heating apparatus, dust collectors, filters, transformers and any other appliance or apparatus, other than flag poles, chimneys for carrying products of combustion and radio antenna towers, shall be enclosed with opaque screens to the extent required and not less in height than the height of the highest appliance, as measured from the plane of the roof surface upon which the screen device is mounted to the top of the highest appliance.

Section 4.49 – Landscaping Requirements and Plant Materials, Buffer Strip and Greenbelt Standards

Whenever landscaping is required, it shall be in accordance with the specific standards as provided in this Section. All plant materials shall be installed within six (6) months of the date of issuance of a Temporary Certificate of Occupancy. In the instance where such completion is not possible, a performance guarantee shall be posted in accordance with this Article.

- a. **Greenbelt or Buffer Strip Planting:** Whenever a greenbelt or buffer strip is required by this Ordinance or as a requirement of site plan or special approval, it shall be installed so as to provide, within a reasonable time, an effective barrier to vision, light, physical encroachment, and sound. Maintenance shall be required to insure its permanent effectiveness.
 - 1. **Greenbelt:** Where required, greenbelts shall conform to the following standards:
 - (a) The greenbelt area will be no less than twenty (20) feet in width.
 - (b) A minimum of one (1) deciduous or evergreen tree shall be planted for each thirty (30) lineal feet or portion thereof of required greenbelt length, or alternatively, eight (8) large deciduous shrubs may be substituted for each required tree. Trees may be planted at uniform intervals, at random, staggered, or in groupings.
 - (1) Deciduous Trees: (2”-2½” caliper): Pin Oak, Norway Maple, Red Maple, Beech, Little Leaf Linden, Green Ash, Honey Locust, Plane Tree.
 - (2) Evergreen Trees (6’ height): Douglas Fir, Pine, and Spruce.

- (3) Large Deciduous Shrubs (24"-30" height spaced at four (4) feet apart): Honeysuckle, Viburnum, Mock Orange, Forsythia, Lilacs, Burning Bush, and Ninebark.
 - (c) Plantings should form an uninterrupted vegetative screen within two (2) years of planting.
 - (d) The remaining ground surface area shall be seeded, sodded, or planted with ground cover. Innovation and design of landscaping and berm placement is encouraged.
 - (e) For the purpose of calculating required plant material, greenbelt length shall be measured along the exterior edge of the greenbelt.
2. **Buffer Strip:** Where required, buffer shall conform to the following standards:
- (a) The buffer area will be no less than ten (10) feet in width.
 - (b) A minimum of one (1) evergreen tree shall be planted at ten (10) foot intervals, and shall have a minimum height of six (6) feet at planting.
 - (1) Medium Evergreens: Juniper, Red Cedar, American Arborvitae (White Cedar).
 - (2) Narrow Pyramidal Evergreens: Pyramidal Arborvitae, Columnar Juniper, and Irish Juniper.
 - (c) Plantings shall be staggered so that an uninterrupted vegetative screen is formed within two (2) years of planting.
 - (d) Interspersed among the evergreen trees shall also be a selection of the following shrubs:
 - (1) Ornamental Deciduous Trees (1 ½"-2" caliper spaced at least ten (10) feet apart): Flowering Crab, Russian Olive, Smoke Tree, Birch, Mountain Ash, Dogwood, Rose of Sharon.
 - (2) Large Deciduous Shrubs (24"-30" in height spaced at four (4) feet apart): Honeysuckle, Viburnum, Mock Orange, Forsythia, Lilacs, Burning Bush, and Ninebark.
 - (e) The remaining ground surface area shall be seeded, sodded, or planted with ground cover. Innovation in design of landscaping and berm placement is encouraged.
3. Berms where provided, shall be at least two (2) feet in height and shall have a slopes no greater than 1:2.5, i.e., one (1) foot of vertical rise for each two and one-half (2.5) feet of horizontal distance.

4. The owner of landscaping required by this Ordinance shall perpetually maintain such landscaping in good condition so as to present a healthy, neat, and orderly appearance, free from refuse and debris. All diseased and/or dead material shall be removed within thirty (30) days following Village notification and shall be replaced within the next appropriate planting season or within one (1) year, whichever comes first.

In the event the owner fails to maintain the landscape area in a neat and orderly manner, free from debris, the Building Official shall mail to the owner a written notice setting forth the manner in which there has been failure to maintain said landscaping and require that the deficiencies of maintenance be cured within thirty (30) days from date of said notice. If the deficiencies set forth in the notice shall not be cured within thirty (30) days, or any extensions thereof granted by the Village shall have right to enter upon such property and correct such deficiencies and the costs thereof shall be charged, assessed and collected.

5. In instances where healthy plant materials exist on a site prior to its development, the Planning Commission may adjust the application of the above standards to allow credit for such plant material if such an adjustment is in keeping with and will preserve the intent of this Ordinance.
- b. **Planting, Soil and Drainage Requirements:** Whenever landscaping is required, the plant materials will be installed in fertile soil with good surface drainage and provided maintenance as required to ensure their health and permanence.

Section 4.50 – Parking and Storage of Campers, Travel Trailers and Boats

- a. Campers, travel trailers, motorized homes, snowmobiles, and trailers of any type and boats may be parked or stored outdoors in any Zoning District on occupied lots subject to the following requirements:
 1. Campers and travel trailers may be parked anywhere on the premises for loading or unloading purposes for a period not to exceed forty-eight (48) hours.
 2. Campers, travel trailers, snowmobiles, trailers, boats and the like, where parked or stored, shall be located only in the side or rear yard and, in addition, shall conform to the required yard space requirements for accessory buildings in the zoning district where located.
 3. The maximum permitted lot coverage of all buildings plus a camper, travel trailer, or boat parking or storage space, shall not be exceeded.
 4. Recreational equipment parked or stored shall not be connected to electricity, water, gas, or sanitary facilities for longer than two weeks, nor shall such equipment be used for living, lodging or housekeeping purposes for longer than two weeks.

Section 4.51 – Sidewalks or Bikeways

For all developments requiring Site Plan approval, either a new public sidewalk or bikeway, or the reconstruction of existing sidewalks or bikeways, shall be required to be constructed to Village standards for the perimeter of the lot that abuts a public street in accordance with the Village Master Plan. Such sidewalks or bikeways shall be aligned with existing sidewalks or bikeways.

Section 4.52 – Reserved

Section 4.53 – Satellite Dish Antennae

Satellite dish antennae may be permitted as an accessory use in any zoning district, subject to the following exceptions:

- a. **Roof-Mounted Antennae:** Roof-mounted dish antennae over four (4) feet in diameter shall be permitted in commercial and industrial districts only, provided that the antennae comply with the height standards for the district in which they are located.
- b. **Ground-Mounted Antennae** – Ground-mounted antennae up to ten (10) feet in diameter shall be permitted in all districts subject to the following conditions:
 1. Maximum height permitted shall be twenty (20) feet.
 2. The satellite dish structure shall be securely mounted and anchored to a pole and secured in accordance with the requirements of the manufacturer and the Building Code.
 3. If elevated off the ground, all such antennae shall be located so that there is an eight (8) foot clearance between the lowest part of the dish and grade.
 4. Satellite dish antennae comply with accessory building setback requirements for the district in which they are located and shall not be permitted in front yards.
 5. All electrical and antenna wiring shall be placed underground or otherwise obscured from view.
 6. The surface of the dish shall be painted or treated as not to reflect glare from sunlight and shall not be used as any sign or message board. All installations shall employ (to the extent possible) materials and colorings that blend with the surroundings.

Section 4.54 – Residential Design Standards

- a. **Scope:** The purpose of this Section is to establish standards governing the design and appearance of all residential structures, including mobile homes and manufactured housing, when developed on individual lots or home sites in the Village of Leonard (hereinafter collectively referred to in this Section as “residential structure”). It is the

intent of these regulations to allow a mix of housing types and living styles in a manner, which will not adversely affect existing neighborhoods. Any residential structure shall be erected or constructed only if in compliance with the following residential design standards.

b. **General Requirements:**

1. **Area and Bulk Regulations:** Any residential structure shall comply with the minimum floor area requirements specified for the zoning district where such structure is located. Mobile homes shall comply with all regulations normally required for site-built housing in the zoning district in which it is located, unless specifically indicated otherwise herein.
2. **Foundation:** Any residential structure shall be placed on a permanent foundation to form a complete enclosure under the exterior walls. The foundation shall be constructed in accordance with the adopted building code of the Village of Leonard. A mobile home shall be installed pursuant to the manufacturer's set-up instructions and shall be securely anchored to its foundation in order to prevent displacement during windstorms in accordance with the Rules and Regulations of the Michigan Mobile Home Commission and shall have a perimeter wall as required. The wheels, tongue, and hitch assembly, and other towing appurtenances shall be removed before attaching a mobile home to its permanent foundation. Additionally, no dwelling shall have any exposed undercarriage or chassis.
3. **Other Regulations:** Residential structures shall be constructed in compliance with applicable State, Federal, or local laws or ordinances, including the Michigan State Construction Code. Mobile homes shall comply with the most recent regulations specified by the United States Department of Housing and Urban Development, Mobile Home Construction and Safety Standards Act, 42 USC § 601, et seq., as amended.
4. **Location:** For the purposes of this Ordinance, a mobile home or other manufactured housing type may be located on an individual lot in any of the zoning districts which allow for the development of single family residential structures, subject further to the regulations contained herein.
5. **Use:** Residential structures shall be used only for the purposes permitted in the zoning district in which they are located.
6. **Attachments:** Any exterior attachments or extensions onto a dwelling unit, such as entry steps and storage buildings, shall comply with the adopted building code of the Village of Leonard.
7. **Services:** Any residential structure shall be connected to a waste treatment and potable water supply system approved by the Oakland County Health Division.

- c. **Design Compatibility Requirements:** To insure the compatibility in appearance with existing homes in the Village, residential structures erected after the effective date of this Ordinance shall comply with the general requirements set forth above and with the following design and site standards.
1. **Roof Pitch:** The pitch of the main roof shall have a minimum vertical rise of one (1) foot for each four (4) feet of horizontal run, and the minimum distance from the eaves to the ridge shall be ten (10) feet, except where the specific housing design dictates otherwise (such as, French provincial, Italianate).
 2. **Roof Drainage:** Residential structures shall be designed with a minimum six (6) inch roof overhang on all sides or an eave with a roof drainage system that will collect and concentrate the roof discharge of storm water or snow away from the sides of the dwelling. The roof shall have wood shake, asphalt or other shingles or other materials commonly used in standard residential construction in the vicinity, and meet or exceed the snow load and strength standards in accordance with all applicable construction code requirements.
 3. **Exterior Materials:** The exterior siding of a residential structure shall consist of materials that are generally acceptable for existing housing in the vicinity, provided that the reflection from such exterior surface shall be no greater than from white semi-gloss exterior enamel, and provided further that any such exterior is comparable in composition, appearance, and durability to the exterior siding commonly used in standard residential construction.
 4. **Dimensions:** The dimensions and placement of residential structures shall be comparable to typical dimensions and placement of existing housing in the vicinity. Therefore, a residential structure shall be located on the lot so that the minimum width of the front elevation is no less than thirty-four (34) feet and the minimum dimension along any side or rear elevation is no less than twenty-four (24) feet. If there are any extensions or additions off of the front of the residential structure, the minimum width of any such secondary front elevation shall be twenty-four (24) feet. Such dimensions shall be measured from the outer extremities and shall include additions to the main body of the home, such as living or recreation rooms, garages, carport, utility rooms, and the like, the front portions of which are within ten (10) feet of the front of the main body of the dwelling.
 5. **Perimeter Foundation Wall:** Every residential structure shall have a foundation wall of the same perimeter dimensions as the residential structure and constructed of such materials and type as required in the applicable building code for single-family dwellings. In the event that a mobile home or manufactured dwelling is installed pursuant to the manufacturer's setup instructions, such residential structure shall be secured to the premises by an anchoring system or device complying with the rules and regulations of the Michigan Manufactured Housing Commission and shall have a perimeter wall as required above.

6. **Exterior Doors:** Residential structures shall have no less than two exterior doors, which shall not be located on the same side of the building. Where required, because of difference in elevation, all exterior doors shall be provided with steps that are permanently attached to the residential structure.
 7. **Design Features:** The design and position of windows and other features of residential structure shall be similar to existing homes within two thousand (2,000) feet of the residential structure. If no more than five (5) existing homes are located within two-thousand (2,000) feet of the proposed location, then the residential structure shall be compared to the nearest fifty (50) existing homes. The foregoing shall not be construed to prohibit innovative design concepts involving such features as solar energy, view, unique land contour, or relief from the common or standard design homes. The compatibility of design and appearance shall be determined in the first instance by the Village Building Official upon review of the plans submitted for a particular residential structure. An appeal may be made to the Zoning Board of Appeals within a period of thirty (30) days from the date of the Building Officials decision and in accordance with Article XXIV – Zoning Board of Appeals.
 8. **Additions:** Each residential structure shall contain no addition or room or other area which is not constructed with similar quality, materials and workmanship as the original structure, including permanent attachment to the principal structure and construction of a foundation as required herein.
 9. **Compliance with All Laws:** Where a dwelling is required by law to comply with any Federal or State standards or regulations for construction and where such standards or regulations for construction are different than those imposed by the Village Building Code, then and that event, such Federal or State standard or regulation shall apply; further provided that the provisions of this Section shall not have the effect of making one family dwellings, which exist as of the effective date of this Ordinance, non-conforming.
 10. **Storage Compartment.** The dwelling shall contain a storage capability area in a basement located under the dwelling, in an attic area, in a closet area, or in a separate structure of standard construction equal to or of better quality than the principal dwelling, which storage area shall be equal to ten (10%) percent of the square footage of the dwelling or one-hundred (100) square feet, which ever shall be less
 11. **Building Permit.** All construction required herein shall be commenced only after a Building Permit has been obtained in accordance with the applicable building code provisions and requirements.
- d. **Mobile Home Compliance:** Mobile homes which do not conform to the above mentioned standards shall not be used for dwelling purposes within the Village unless located within a licensed mobile home park, or unless used for temporary residential purposes.

1. **Accessory Structures:** Detached accessory structures, as permitted in this Ordinance shall be built in accordance with the Village of Leonard Building Code. If the accessory structure is attached to the residential structure, it shall be similar in material and integrity and meet the construction standards of the HUD National Manufactured Housing Construction and Safety Standards Act of 1974 or the Michigan Construction Code, as applicable.
2. **Permits:** No mobile home or manufactured dwelling unit shall be delivered to any lot in the Village of Leonard until it is shown that the requirements of this Ordinance can be met. Prior to the installation of a mobile home or manufactured house on a residential lot, the individual shall obtain a Building Permit from the Clerk.

Section 4.55 – Reserved

Section 4.56 – Automobile Service Stations and Public Garages

In order to regulate and control the problem of noise, odor, light, fumes, vibration, dust, danger of fire and explosion and traffic congestion which result from the unrestricted and unregulated construction and operations of automobile service stations, and to regulate and control the adverse effects which these and other problems incidental to the automobile service station may exercise upon adjacent and surrounding areas, the following additional regulations and requirements are provided herein for automobile service stations located in any zone. All automobile service stations erected after the effective date of this Ordinance shall comply with all requirements of this Section. No automobile service station existing on the effective date of this Ordinance shall be structurally altered so as to provide a lesser degree of conformity with the provisions of this Section that existed on the effective date of this Ordinance.

- a. An automobile service station shall be located on a lot having a frontage along the principal street of no less than one-hundred and forty (140) feet, and having a minimum area of not less than fourteen thousand (14,000) square feet.
- b. An automobile service station building housing a garage, office and/or facilities for servicing, greasing, and/or washing motor vehicles shall be located not less than forty (40) feet from any street right-of-way or interior lot line, and not less than twenty-five (25) feet from any side or rear lot line adjoining a residential zoned district.
- c. All driveways providing ingress to or egress from an automobile service station shall be not more than thirty (30) feet wide at the lot line. No more than one (1) curb opening shall be permitted for each fifty (50) feet of frontage or major fraction thereof along any street. No driveway or curb opening shall be located nearer than twenty (20) feet to any intersecting street rights-of-way or adjacent residential property. No driveway shall be located nearer than thirty (30) feet, as measured along the property line, to any other driveway giving access to or from the same automobile service station.

- d. That portion of the lot to be used for vehicle access, maneuvering, and parking and permitted storage shall be hard surfaced with concrete or a plant-mixed bituminous material. All landscaped areas shall be separated from all paved areas by a raised curb.
- e. All lubrication equipment, motor vehicle washing equipment, hydraulic hoists, and pits shall be enclosed entirely within a building. All gasoline pumps shall be located less than twenty (20) feet from any lot line, and shall be arranged so that motor vehicles being supplied with gasoline or serviced shall not be parked upon or over-hanging public sidewalk, street or right-of-way.
- f. An automobile service station shall include not more than four (4) double gasoline pumps or eight (8) single gasoline pumps and three (3) enclosed stalls for servicing, lubricating, greasing, or washing motor vehicles.
- g. All exterior lighting, including illuminated signs, shall be erected, hooded, or shielded so as to be deflected away from adjacent and neighboring property.
- h. Where an automobile service station adjoins residentially zoned property, masonry wall five (5) feet in height shall be erected and maintained along the service station property line. All masonry walls shall be protected by a fixed curb or barrier to prevent vehicles from contacting the wall.
- i. Outdoor storage or parking of vehicles other than private automobiles shall be prohibited between the hours of 10:00 pm and 7:00 am. There shall be no equipment, vehicle rental or sale operations conducted on the premises.
- j. Abandoned automobile service stations or gasoline filling stations may be converted to a principle permitted use in the district in which such station is located, providing the following conditions are met:
 - 1. The use shall not be out of harmony with the surrounding neighborhood by reason of its character or quality of development.
 - 2. All gasoline pumps and signs shall be removed, and underground gasoline storage tanks shall be abandoned in conformance with prescribed Village, County, and State fire safety provisions.
 - 3. All buildings shall meet all applicable requirements of the Village Building Code for safety and structural condition.
 - 4. There shall be adequate off-street parking provided in accordance with this Ordinance.
 - 5. No outside storage areas shall be permitted.
 - 6. The use shall meet all area, height, bulk, and placement requirements of the district in which such use is located in accordance with Article XVIII - Schedule of Regulations.

7. The use shall comply with all other requirements of this applicable district unless otherwise provided in this Ordinance.
- k. All automobile service stations shall conform to the Village of Leonard Fire Code Ordinance, as amended.

Section 4.57 – Outdoor Wood Fired Stove or Furnace

- a. **Intent:** It is the intent of this Section to enhance and promote the public health, safety, and welfare and to safeguard the health, comfort, and living conditions of the citizens by regulating the air pollution and fire hazards generated by the use of outdoor wood fired stove or furnace.
- b. **Definitions:**
 1. **ALLOWABLE FUELS:** Fuels that are allowed in wood stove/furnace are clean woods (wood having none of the characteristics of definition “Prohibited Fuels”), wood pellets made from clean wood, manufacturer approved fuels unless they are Prohibited Fuels. Dual Fired Outdoor Wood Fired Stove/Furnaces may use home heating oil that complies with the applicable sulfur content limits or natural gas as starter fuels.
 2. **OUTDOOR WOOD FIRED STOVE/FURNACE:** A structure that is designed and that the manufacturer specifies for outdoor installation or installation in structures not normally occupied by humans, intended or used to provide heat and/or hot water (hydronic) to any residence or other structure, operates by burning of wood or other solid fuel and is not located within a structure used for human or animal habitation. This includes without limitation any structure, equipment, device, or apparatus, or any part thereof, which is installed, affixed, constructed or located outdoors for the primary purpose of combustion of solid fuel, including but not limited to wood, to produce heat or energy used as a component of a heating system.
 3. **PROHIBITED FUELS:** Fuels that are prohibited for use in Outdoor Wood Stove/Furnace are: any wood that has paint, stains, or any other coatings, including sealants, copper chromium arsenate, creosote, or pentachlorophenol. Any refuse defined herein, tires, lawn clippings, leaves, brush trimmings, yard waste, plastic materials, rubber materials, petroleum products, paints and paint thinners, chemicals, coal, paper/cardboard except for initial startup, plywood, composite wood, particleboard, salt water driftwood, manure, animal carcasses, asphalt products, lighter fluids, gasoline, or any other material prohibited for combustion by State or Federal Law or Regulations.
- c. **General Regulations:**
 1. The stove or furnace shall be for the purpose of heating a dwelling and/or accessory structure(s) on the same lot.

2. The lot shall be a minimum of one (1) acre in area in all zoning districts.
3. The stove or furnace shall be forty (40) feet from any other structure.
4. The stove or furnace shall be located a minimum of fifty (50) feet from any property line.
5. The stove or furnace shall not be located in the front yard. All firewood stored on property shall be stored in the side yard or rear yard and stacked neatly.
6. An area at least ten (10) feet in diameter around the stove or furnace shall be free of combustible material.
7. The outdoor stove or furnace shall utilize a chimney with a minimum height of twenty (20) feet from the highest part of the stove or furnace.
8. The outdoor stove or furnace shall only burn Allowable Fuels for which it is designed and manufactured for in the unit. The outdoor stove or furnace shall not be used to burn Prohibited Fuels.
9. The stove or furnace shall not constitute a nuisance to neighboring properties.
10. The outdoor stove or furnace and any electrical, plumbing, mechanical, or other apparatus or device in connection with an outdoor stove or furnace shall be installed, operated, and maintained in conformity with all local, state, and federal manufacturer's specifications codes, laws, rules, regulations, and permits.
11. No person or entity shall construct, install, use, operate, or permit to be operated an outdoor wood fired stove or furnace without first obtaining a permit from the Building Official. Installation of all new units requires an initial permit application and fee following the effective date of this Ordinance. Said application shall include a survey or acceptable sketch (at the discretion of the Building Official) showing all property lines, the locations and distances of all dwellings or occupied buildings on adjoining properties within three hundred (300) feet of the property line, and the proposed location of the structure. All units, new or used, shall carry a tag certifying that the structure complies with the EPA Phase II Emission standard, or higher as defined by the EPA, which standard is herein incorporated by reference.
12. All existing outdoor wood fired stove or furnace in operation at the time of passage of this regulation are hereby permitted to remain. Any change in ownership or use of the property having a non-conforming outdoor wood fired stove or furnace will require that any deviations in chimney height from these regulations for outdoor wood fired stove or furnace installation adopted after said installation is met in so far as practical.
13. The stove or furnace must be in compliance with the Village Fire Code Ordinance. The Fire Code Official is authorized to order that measures be taken

to prevent the operation of an existing stove or furnace found to be defective or in violation of the Fire Code Ordinance. Further, the Fire Code Official is authorized to take measures to prevent the operation of a stove or furnace when inspection shows the existence of an immediate fire hazard or constitutes an imperilment to human life.

Section 4.58 – Reserved

Section 4.59 – Wind Energy Systems

- a. **Intent:** Regulate the use and placement of Wind Energy Systems. The purpose of this Section is to accommodate distributed generation Wind Energy Systems in appropriate locations, while minimizing any adverse visual, safety, and environmental impacts of the system in the Village. This Section also provides a permitting process for Wind Energy Systems to ensure compliance with the provisions of the requirements and standards established herein. This Section is intended to preserve and protect the health, safety, and welfare of the public.
- b. **Definitions:**
1. **TOTAL HEIGHT:** The vertical distance from ground level to the tip of the wind turbine blade when it is at its highest point plus twenty-five (25 feet).
 2. **TOWER:** The monopole or guyed monopole structure that supports a wind turbine.
 3. **WIND ENERGY SYSTEM:** A wind energy conversion system consisting of a wind turbine, a tower, and associated control or conversion electronics, which has a rated capacity of sixty (60) kilowatts or less and will be used primarily for on-site consumption. For the purpose of this Section, Wind Energy System is not considered an (AG)Agricultural use for purposes of the Michigan Right to Farm Act, Public Act 93 of 1981, and as such, requires a Building Permit.
 4. **WIND TURBINE:** The blades and associated mechanical and electrical conversion components mounted on top of the Tower whose purpose is to convert kinetic energy of the wind into rotational energy used to generate electricity.
- c. **General Regulations:**
1. All Wind Energy Systems shall be allowed in the AG - Agriculture Zoning District subject to the regulations in this Section. The minimum setback distance specified herein shall determine minimum parcel size. A Building Permit must be obtained prior to construction.
 2. The setback shall be equal to the total height of the Wind Energy System including the top of any blade in its uppermost vertical position plus twenty-five (25) feet from:

- (a) Any public road right of way.
 - (b) Any overhead utility lines.
 - (c) Any travel ways to include but not be limited to driveways, parking lots, nature trails or sidewalks.
 - (d) Any property line to abutting parcels or lots.
 - (e) Any structure unless the design of the Wind Energy System is specifically engineered to control the collapse of the structure in the event of structural failure or the system is designed for placement on a structure or building other than freestanding or guyed towers and evidenced by a professional engineer.
3. Sound pressure levels shall not exceed 55 dB(A) at the property line closest to the Wind Energy System. This sound pressure level may be exceeded during short-term events such as utility outages and/or severe windstorms. If the ambient sound pressure level exceeds 55 dB(A), the standard shall be ambient dB(A) plus 5 dB(A).
4. All Wind Energy Systems shall have automatic braking, governing, or a feathering system to prevent uncontrolled rotation or over speeding. All towers shall have lightning protection. If a system is supported by guy wires, the wires shall be made clearly visible by sheathing or other coating applied to a height of at least six (6) feet above the guy wire anchors at ground level. The minimum vertical blade tip clearance from grade shall be twenty (20) feet for a wind energy system employing a horizontal axis rotor.
5. All Wind Energy Systems shall comply with all applicable state construction and electrical codes; local building permits and inspections are required.
6. All Wind Energy Systems shall have a site drawing prepared by a registered surveyor or civil engineer in a form acceptable to the building official with the application for a Building Permit. The Site Plan shall include:
- (a) Property lines and physical dimensions of the property.
 - (b) Zoning classification of the property and adjacent parcels.
 - (c) Location, dimensions, and types of existing major structures on the property.
 - (d) Location of the proposed wind energy system tower and the distance dimensions from structures and property lines.
 - (e) The right-of-way of any public road that is contiguous with the property.

- (f) Any overhead or underground utility lines.
 - (g) Wind System specifications, including manufacturer and model, rotor diameter, tower height, and tower type (free-standing, guyed or building mounted).
 - (h) Tower foundation blueprint or drawing.
 - (i) Tower blueprint or drawing with civil engineer or architectural seal certifying the Wind Energy System and appurtenant documentation.
 - (j) If the Wind Energy System will be connected to the power grid, documentation shall be provided regarding the notification of the intent with the utility regarding the applicant's installation of a Wind Energy System.
 - (k) Sound level analysis prepared by the wind turbine manufacturer or qualified engineer.
 - (l) Evidence of compliance or non-applicability with Federal Aviation Administration requirements.
 - (m) Prior to issuance of a Building Permit, a pre-construction onsite inspection of the proposed Wind Energy System site shall be made by the Building Official.
7. A Building Permit issued pursuant to this Section shall expire if the Wind Energy System is not installed, functional and approved within twelve (12) months.
8. Should the Wind Energy System be abandoned or out of service, damaged or unused for a continuous twelve (12) month period the Village Building Official may require that the Wind Energy System be inspected for compliance with Village regulations and the use of it terminated or removed from the property. After the twelve (12) months of inoperability, the Building Official may issue a Notice of Abandonment to the owner of the Wind Energy System.

The owner shall have the right to respond to the Notice of Abandonment within thirty (30) days from Notice receipt date. The Building Official shall withdraw the Notice of Abandonment and notify the owner that the Notice has been withdrawn if the owner provides information that demonstrates the Wind Energy System has not been abandoned. If the owner fails to respond to the Notice of Abandonment or if after review by the Building Official it is determined that the Wind Energy System has been abandoned or discontinued, the owner of the Wind Energy System shall remove the wind turbine and tower at the owner's sole expense within 3 months of receipt of the Notice of Abandonment. If the owner fails to physically remove the Wind Energy System after the Notice of Abandonment procedure, the Village may seek a court order authorizing it to

enter the subject property and physically remove the Wind Energy System and recover the cost of doing so by lien or other means.

Section 4.60 – Reserved

Section 4.61 – Reserved

Section 4.62 – Condominium Projects

The purpose of this Article is to regulate Condominium Projects. New and conversion condominium projects shall conform to the requirements of this Ordinance, all other applicable Village regulations, and the Condominium Act (Public Act 59 of 1978, as amended). Each condominium project shall be reviewed in a manner consistent with equivalent projects within the development district.

The following additional regulations shall apply to all Condominium Projects within the Village:

- a. **Initial Information Required:** Concurrently with the Notice required to be given to the Village pursuant to Public Act 59 of 1978, as amended (the Condominium Act), the following information with respect to any Condominium Project shall be provided to the Village Clerk by any persons intending to develop a condominium project:
 1. The name, address, and telephone number of:
 - (a) All persons with an ownership interest in the land on which the condominium project will be located together with description of the nature of each entity's interest (for example, fee owner, optionee, lessee, or land contract vendee).
 - (b) All engineers, attorneys, architects, or registered land surveyors associated with the project.
 - (c) The developer or proprietor of the condominium project.
 2. The legal description of the land on which the condominium project will be developed together with appropriate tax identification numbers.
 3. The acreage area of the land on which the condominium project will be developed.
 4. The proposed use of the project (for example, residential, commercial, industrial, etc.).
 5. Approximate number of condominium units to be developed on the subject parcel.
 6. Whether or not a community water system is contemplated.
 7. Whether or not a community septic system is contemplated.

- b. **Information to be Updated:** All information required to be furnished under this Section shall be kept updated until such time as a Certificate of Occupancy has been issued.
- c. **Pre-Application Conference (Optional)**
1. A potential applicant for a Condominium Project may request a pre-application conference prior to filing an application. The request shall be made to the Village Clerk, who shall set a date and shall inform the Village President and the Chairperson of the Village Planning Commission of the pre-application conference and invite their attendance. The Village Clerk shall also invite other officials, consultants, or staff who might have an interest in the proposed development, or who might assist the Village in the review process.
 2. The applicant shall present at such a conference(s), at minimum, proof of interest in the property, a sketch plan of the proposed Condominium Project (drawn to scale); a legal description of the property in question; the total number of acres in the project; floor area of single family, multi-family, and areas to be designated as common areas or open space.
 3. The purpose of the meeting is to inform Village and other Officials of the concept of the proposed development and provide the potential applicant with information regarding land development policies, procedures, standards and requirements of the Village in terms of the proposed development. To this end, the applicant is encouraged to present schematic plans, site data, and other information that will explain the proposed development.
 4. Statements made at the pre-application conference shall not be legally binding commitments.
- d. **Site Plan Review and Engineering Review:** Prior to recording of the Master Deed required by Section 72 of Public Act 59 of 1978, as amended (MCL 559.172), the Condominium Project shall undergo Site Plan Review and approval pursuant to Article XXV – Site Plan Review of this Ordinance. In addition, the Village shall require appropriate engineering plans and inspections prior to the issuance of any Certificates of Occupancy.
- e. **Site Plan Review for Expandable or Convertible Projects:** Prior to expansion or conversion of a Condominium Project to additional land, the new phase of the project shall undergo Site Plan Review and approval pursuant to Article XXV- Site Plan Review of this Ordinance.
- f. **Master Deed, Restrictive Covenants, and “As Built” Survey:** The Condominium Project Developer or Proprietor shall furnish the Village Clerk with the following: One (1) copy of the recorded Master Deed, one (1) copy of all restrictive covenants and two (2) copies of an “as built survey.” The “as built survey” shall be reviewed by the Village Clerk for compliance with Village Ordinances. Fees for this review shall be established by resolution of the Village Council. The Building Official may withhold issuing any Certificate of Occupancy for any structure within the condominium project, if such

documents have not been submitted within ten (10) days after written request from the Building Official to do so.

- g. **Monuments Required – Site Condominium Projects:** All Condominium Projects which consist in whole or in part of condominium units which are building sites, mobile home sites, or recreational sites shall be marked with monuments as prescribed by the rules of the state of Michigan and as provided in this subsection.
1. Monuments shall be located in the ground and made according to the following requirements, but it is not intended or required that monuments be placed within the traveled portion of a street to mark angles in the boundary of the condominium project if the angle points can be readily reestablished by reference to monuments along the sidelines of the streets.
 2. All monuments used shall be made of solid iron or steel bars at least one-half (1/2) inch in diameter and thirty-six (36) inches long and completely encased in concrete at least four (4) inches in diameter.
 3. Monuments shall be located in the ground at all angles in the boundaries of the Condominium Project; at the intersection lines of streets and at the intersection of the lines of streets with the boundaries of the condominium project; at all points of curvature, points of tangency, points of compound curvature, points of reverse curvature and angle points in the side lines of streets and alleys; at all angles of an intermediate traverse line and at the intersection of all limited common elements and all common elements.
 4. If the required location of a monument is an inaccessible place, or where the location of a monument would be clearly impracticable, it is sufficient to place a reference monument nearby and the precise location thereof be clearly indicated on the plans and referenced to the true point.
 5. If a point required to be marked by a monument is on a bedrock outcropping, a steel rod, at least one-half (1/2) inch in diameter shall be drilled and grouted into solid rock to a depth of at least eight (8) inches.
 6. All required monuments shall be placed flush with the ground where practicable.
 7. All unit corners shall be marked by a monument in the field by iron or steel bars or iron pipes at least eighteen (18) inches long and one-half (1/2) inch in diameter, or other approved markers.
 8. The Village Council may waive the placing of any of the required monuments and markers for a reasonable time, not to exceed one (1) year, on the condition that the proprietor deposits with the Village Clerk cash or a certified check, or irrevocable bank letter of credit running to the Village, whichever the proprietor selects, in an amount not less than twenty-five dollars (\$25.00) per monument and not less than one hundred dollars (\$100.00) in total. Such cash, certified check, or irrevocable bank letter of credit shall be returned to the proprietor upon receipt of

a certificate by a surveyor that the monuments and markers have been placed as required within the time specified.

- h. **Monuments Required – All Condominium Projects:** All Condominium Projects shall be marked at their boundaries with monuments meeting the requirements above.
- i. **Compliance with Federal, State, and Local Law:** All Condominium Projects shall comply with Federal and State statutes and local ordinances.
- j. **State and County Approval:** The developer or proprietor of the Condominium Project shall establish that appropriate state and county approvals have been received with regard to the fresh water system for the proposed project and with regard to the waste water disposal system for the proposed project.
- k. **Temporary Occupancy:** The Village Council may allow occupancy of the Condominium Project before all improvements required by this Ordinance are installed, provided that a performance guarantee is submitted sufficient in amount and type to provide for the installation of improvements before the expiration of the temporary occupancy permit without expense to the Village.
- l. **Single Family Detached Condominiums:** Single family detached condominiums shall be subject to all requirements and standards of the applicable AG, R1-F, R-1, and R-2 Districts including minimum floor area requirements, but not including minimum lot size.

There shall be maintained a minimum distance from the center of one (1) residential dwelling unit to the center of another residential dwelling unit equal to the requirements for the applicable zoning district set forth in Article XVIII - Schedule of Regulations. This requirement shall be computed along the front building line. In addition, building envelopes shall be depicted on the Site Plan to assure that the minimum requirements set forth in Article XVIII - Schedule of Regulations for front yard, rear yard, side yard (least one), and total of two (2) side yards can be met.
- m. **Single Family Site Condominiums:** Single Family Site Condominiums shall be subject to all requirements applicable to AG, R1-F, R-1, and R-2 Districts, including minimum lot requirements which shall be applied by requiring the Site Condominium Unit and a surrounding limited common element to be equal in size to the minimum lot size. The site condominium unit shall be equivalent to the area of the lot where a principal building can be constructed and there shall be a limited common element associated with each Site Condominium unit which shall be at least equivalent to the minimum yard area requirements.
- n. **Street and Road Requirements in All Single Family Detached and Single Family Site Condominiums:** All internal streets and roads in a Single Family Detached Condominium project, or a Single Family Site Condominium Project shall, at a minimum conform to the Village Ordinances, and the standards and specifications promulgated by the Road Commission for Oakland County for a typical residential road in single family residential subdivisions.

- o. After submittal of the condominium plan and by-laws as part of the Master Deed, the developer or proprietor shall furnish to the Village a copy of the site plan on a mylar sheet of at least thirteen by sixteen (13 x 16) inches with an image not to exceed ten and one-half by fourteen (10 ½ x 14) inches.
- p. **Recordation:** The developer or proprietor shall record all condominium documents and exhibits with the County Register of Deeds in a manner and format acceptable to the County and deliver proof of such recording to the Village.
- q. **Expiration:** Condominium Site Plans shall expire 365 days after the date of approval, or the life of the Building Permit obtained pursuant to the approved site plan, whichever is longer. Upon written request received by the Village prior to the expiration date, the Planning Commission may grant one (1) extension of final approval for up to 365 days, provided that site conditions have not changed in a way that would affect the character, design or use of the site, and that the approved plan remains in conformance with all application provisions of this Ordinance.
- r. **Amendments:** Amendments to any condominium document that significantly impact the approved condominium site plan, or any conditions of the condominium site plan approval, shall be submitted to the Planning Commission and Village Council for review and approval, prior to the issuance of a building permit.

Section 4.63 – Single Family Cluster Option

Except as stated within this Section, an application for approval of a Site Plan for a Residential Cluster Option shall follow the procedures and requirements established for a Special Use Approval as stated in Article XXVI – Special Approval Procedures and Standards. The following standards shall apply to Single Family Cluster Projects:

- a. **Intent:** The intent of the Single Family Cluster option is to provide the opportunity for creative design in single family residential districts to accomplish the following primary objectives:
 - 1. To promote a higher quality of development than could be achieved under conventional zoning regulations.
 - 2. To encourage innovation in land use and variety of design, layout, and type of structures constructed.
 - 3. To provide a feasible means of residential development on sites that would otherwise be difficult or impossible to develop because of the parcel size or shape, the character of surrounding land uses, or other constraints.
- b. **Eligibility Criteria:** In considering any proposal for the Single Family Cluster Option, the Planning Commission shall determine that the proposal satisfies one or more of the following eligibility criteria:

1. The overall impact of the development will provide a recognizable and substantial benefit to its ultimate residents and to the community.
2. The parcel has narrow width, shallow depth, or an unusual configuration that is a substantial detriment to development as a conventional subdivision.
3. A significant portion of the property's perimeter is bordered by a major paved public street so that, if developed as a conventional subdivision, a substantial number of the lots would abut the street and be impacted by negative traffic noise and lights.
4. A substantial portion of the property's perimeter is bordered by land that is zoned or used for more intensive and potentially incompatible non-residential development.
5. The parcel contains natural assets that would be preserved or enhanced through the use of Cluster Development. Such assets may include stands of trees, land that serves as a habitat for wildlife, unusual topographic features, wetlands or other natural assets that should be preserved.

An application for the Single Family Cluster Option shall be accompanied by written and graphic documentation demonstrating to the Planning Commission that the proposal satisfies one or more of the listed eligibility criteria.

- c. **Project Density:** The overall density of development on a site that qualifies for Cluster Development shall not exceed the standards for density as established by the underlying zoning regulations for the district in which the site is located. The density of a development shall be computed by dividing the total number of units proposed by the allowable acreage. The quotient shall be rounded to the nearest tenth (10th) of an acre.

For the purpose of computing density, allowable acreage shall include the following:

1. All areas to be used for residential purposes, including off-street parking and private access roads, but excluding public street right-of-ways;
2. Dedicated private parks and/or common open space devoted for use of residents of the single family cluster development.

- d. **Site Design Requirements:** Single family cluster developments shall comply with the following requirements:

1. **Clustering Alternatives:**

- (a) **Attachment of Units:** A maximum of four (4) single family dwelling units may be attached to each other provided that measures are taken to avoid monotonous façade design or the appearance of massive buildings that are out-of-scale with surrounding single-family development. The attached units shall be offset from one another, and/or different design

details (i.e., different building entrance designs, different building materials, etc.) shall be used for each unit.

- (b) **Detached Clusters:** A maximum of four (4) single family detached units may be combined into a single cluster, provided the units be spaced not less than twenty (20) feet apart. This spacing requirement may be waived or modified by the Planning Commission during site plan review, based upon a favorable recommendation of the Village Fire Chief.

2. **Open Space:**

- (a) **General Requirements:** Single family cluster developments shall provide and must maintain at least fifteen percent (15%) of the site as dedicated common open space.
- (b) **Water Bodies and Basins:** Up to twenty-five percent (25%) of the required open space may include the area of any created water bodies or water detention/retention basins.
- (c) **Conveyance of Open Space:** The required open space shall be set aside by the developer through an irrevocable conveyance, such as a deed restriction(s) or covenant(s) that run with the land, assuring that the open space will be developed, dedicated and continually maintained according to site plan and never changed to another use.

3. **Setbacks:**

- (a) **Setbacks between Clusters:** Each cluster of attached or detached dwelling units shall be set back a minimum distance of fifty (50) feet from any other cluster, except that the minimum setback for adjoining cluster that have a side-to-side building relationship shall be twenty (20) feet.
- (b) **Building Setbacks:** Buildings within each cluster shall comply with the following minimum setbacks:
 - (1) Internal private road: twenty (20) feet from edge of traveled roadway; and
 - (2) Public road right-of-way: twenty-five (25) feet; and
 - (3) Property line (other than road right-of-way): twenty-five (25) feet; and
 - (4) Utility easement (other than individual unit lead): twelve (12) feet.

- 4. **Transition in Density:** Where the parcel proposed for use as a cluster development abuts a conventional single family development, the cluster development shall be designed to provide an orderly transition between the two

developments. Such a transition may be achieved by providing a buffer zone consisting of any of the following: open space, additional landscaping, berms, changes in topography, or similar measures.

5. **Sidewalks:** Sidewalks shall be provided along all public and private roads within the cluster development.
- e. **Determination of Eligibility:** The application for Cluster Development shall include documentation that the proposal satisfies one or more of the eligibility criteria set forth in this Section. The Planning Commission shall make a preliminary determination whether the proposal qualifies for the cluster option, based on the submitted documentation.
- f. **Effect of Preliminary Eligibility Determination:** Preliminary determination by the Planning Commission that a parcel qualifies for Cluster Development does not assure approval of the Site Plan. Such a determination, however, does give the applicant the opportunity to proceed further with site plan review.
- g. **Site Plan Review:** A Cluster Housing Development shall be subject to the Site Plan review requirements in Article XXV - Site Plan Review of this Ordinance, as well as the additional requirements in this Section.
- h. **Information Required for Site Plan Review:** In addition to the information required in Article XXV - Site Plan Review as part of Site Plan review, the following information shall be included on all cluster option plans submitted for review:
 1. Acreage and density computations.
 2. Setbacks from all property lines and distances between all buildings and between buildings and roads.
 3. Proposed landscape screening along the perimeter and within the site.
 4. Specific locations of significant site features such as tree stands and water retention areas.
 5. Delineation of open space areas and detailed information concerning common access and proposed landscaping or other improvements within the open space.
- i. **Recording of Planning Commission Action:** Each action taken with reference to a Cluster Development proposal, including the grounds for the action taken, shall be duly recorded in the minutes of the Planning Commission.
- j. **Recording of Documents:** If the Planning Commission approves the Cluster Development proposal, all requirements and conditions upon which such approval is based shall be included as part of the approved site plan. Easements, deed covenants or deed restrictions shall be drafted into recordable form, reviewed and approved as to form by the Village Attorney, and filed by the applicant, with the appropriate County agency prior to the issuance of a Building Permit for any construction.

- k. **Performance Guarantee:** A Performance Guarantee shall be deposited with the Village to insure faithful completion of improvements, in accordance with this Article.

Section 4.64 – Approval of Plats

No proposed plat of a new subdivision shall hereinafter be approved by the Village Council unless the lots within such plat equal or exceed the minimum size and width requirements set forth in the various districts of this Ordinance, and unless such plat fully conforms with the statutes of the State of Michigan and the Ordinances of the Village of Leonard.

ARTICLE V

NONCONFORMITIES

Section 5.01 – Intent

Any lawful use of the land or buildings existing at the date of passage of this Ordinance, or subsequent amendment thereto, and located in a district in which it would not be permitted as a new use under the regulations of this Ordinance, is hereby declared to be a "nonconforming use" and not in violation of this Ordinance; provided, however, that a nonconforming use shall be subject to, and the owner shall comply with, the regulations of this Article.

Such uses are declared by this Ordinance to be incompatible with permitted uses in the districts involved. It is the intent of this Ordinance to permit such nonconformities to continue until they are removed or abandoned. It is further the intent of this Ordinance that nonconformities shall not be enlarged upon, expanded or extended, nor be used as ground for adding other structures or used prohibited elsewhere in the same district. All nonconformities shall be encouraged to convert to conformity whenever possible, and shall be required to convert to conforming status as required by this Article.

Section 5.02 – Nonconforming Uses of Land

Where, at the effective date of adoption or amendment of this Ordinance, a lawful use of land exists which would not be permitted under the terms of this Ordinance as enacted or amended, and where such use involves no building or structure, such use may be continued so long as it remains otherwise lawful, subject to the following provisions:

- a. No such nonconforming use shall be enlarged, increased, or extended to occupy a greater area of land than was occupied at the effective date of adoption or amendment of this Ordinance.
- b. No such nonconforming use shall be moved in whole or in part to any other portion of the lot or parcel occupied by such use at the effective date of adoption or amendment of this Ordinance.
- c. If such nonconforming use of land ceases for any reason for a period of more than six (6) months, any subsequent use of such land shall conform to the regulations specified by this Ordinance for the district in which such land is located.
- d. No additional structure not conforming to the requirements of this Ordinance shall be erected in connection with such non-conforming use of land.

Section 5.03 – Nonconforming Uses of Structures

If a lawful use of a structure, or of structure and premises in combination, exists at the effective date of adoption or amendment of this Ordinance, such use may be continued so long as it remains otherwise lawful, subject to the following provisions:

- a. No existing structure devoted in whole or in part to a use not permitted by this Ordinance in the district in which it is located shall be enlarged, extended, constructed, reconstructed, moved, or structurally altered except in changing the use of the structure to a use permitted in the district in which it is located.
- b. Any nonconforming use may be extended throughout any parts of a building which were manifestly arranged or designed for such use, and which existed at the time of adoption or amendment of this Ordinance, but no such use shall be extended to occupy any land outside such building.
- c. If no structural alterations are made, any nonconforming use of a structure, or structure and premises, may be changed to another nonconforming use provided that the Zoning Board of Appeals, by making findings in the specific case, shall find that the proposed use is more appropriate to the district than the existing nonconforming use. In permitting such change, the Zoning Board of Appeals may require appropriate conditions and safeguards in accord with the purpose and intent of this Ordinance. Whenever a nonconforming use has been changed to a conforming use, or to a use permitted in a more restricted district, it shall not thereafter be changed to nonconforming use or a use not permitted in the more restricted district.
- d. When a nonconforming use of a structure, or structure and premises in combination, is discontinued or ceases to exist for a period of six (6) consecutive months or more, or is otherwise sooner abandoned, such structure, or structure and premises in combination, shall conform to the regulations of the Zoning District in which such use is located. Structures occupied by seasonal uses as permitted by this Ordinance shall be exempt from this provision.
- e. Where nonconforming use status applies to a structure and premises in combination, removal or destruction of the entire structure shall eliminate the nonconforming status of the land.

Section 5.04 – Nonconforming Structures

Where a lawful structure exists at the effective date of adoption or amendment of this Ordinance that could not be built under the terms of this Ordinance by reason of restrictions on area, lot coverage, height, yards, or other characteristics of the structure or its location on the lot, such structure may be continued so long as it remains otherwise lawful, subject to the following provisions:

- a. No such nonconforming structure may be enlarged or altered in a way which increases or intensifies its nonconformity, but any such structure or portion thereof may be enlarged or altered in a way which does not increase nor intensify its nonconformity.
- b. If such non-conforming structure should be destroyed by any means to an extent of more than one hundred and twenty (120%) percent of its state equalized value at the time of destruction, it shall not be reconstructed except in conformity with the provisions of this Ordinance.

- c. Should such structure be moved for any reason for any distance whatever, it shall thereafter conform to the regulations for the district in which it is located after it is moved.
- d. Nothing contained in this Article shall, however, prohibit a single family residential homeowner from improving his homestead by an enlargement or alteration of the homestead structure so long as the enlargement or alteration thereto is in keeping as near as reasonably can be with the provisions contained in this Ordinance and provided such improvement receives the prior approval of the Zoning Board of Appeals; provided further that any homestead destroyed by any means, except voluntary destruction, to an extent of more than one hundred and twenty (120%) percent of its state equalized values at the time of destruction, may be reconstructed by a homeowner as his homestead provided such reconstruction meets the provisions of this Ordinance as near as reasonably can be and such reconstruction receives the prior approval of the Zoning Board of Appeals.

Under this paragraph, a homeowner may only have one (1) homestead in the Village of Leonard and such homestead must be his sole residence in the Village and he must be residing in or have resided therein at time application to enlarge, alter or reconstruct is applied for.

- e. On any non-conforming structure or portion of a structure devoted in whole or in part to any nonconforming use, work may be done in any period of twelve (12) consecutive months on ordinary repairs, or on repair or replacement of non-bearing walls, fixtures, wiring or plumbing to an extent not exceeding one hundred twenty (120%) percent of the current State Equalized Value of the non-conforming structure or portion of the structure as the case may be, provided that the cubic content as it existed at the time of passage or amendment of this Ordinance shall not be increased.

If a non-conforming structure or portion of a structure containing a non-conforming use becomes physically unsafe or unlawful due to a lack of repairs and maintenance, and is declared by the Building Inspector to be unsafe or unlawful by reason of physical condition, it shall not thereafter be restored, repaired, or rebuilt except in conformity with the regulations of the district in which it is located.

- f. Nothing in this Ordinance shall prevent the reconstruction, repair, or restoration and the continued use of any nonconforming building or structure damaged by fire, collapse, explosion, acts of God or acts of public enemy, subsequent to the effective date of the Ordinance, wherein the expense of such reconstruction does not exceed one hundred twenty (120%) percent of the State Equalized Valuation of the entire building or structure at the time such damage occurred; and provided that such restoration and resumption shall take place within six (6) months of the time of such damage and that it be completed within one (1) year from time of such damage, and provided further, that said use be identical with the nonconforming use permitted and in effect directly preceding said damage. Where pending insurance claims require an extension of time, the Building Official may grant a time extension provided that the property owner submits a certification from the insurance company attesting to the delay. Until such time as the

debris from the fire damage is fully removed, the premises shall be adequately fenced or screened from access by children who may be attracted to the premises.

Section 5.05 – Nonconforming Lots of Record

The purpose of these provisions is to permit utilization of recorded lots which lack adequate required width or depth as long as reasonable living standards can be provided. Such lots must be in separate ownership and not of continuous frontage with other lots in the same ownership.

a. Single Lot of Record

In any district in which single-family dwellings are permitted, notwithstanding limitations imposed by other provisions of this Ordinance, a single-family dwelling and customary accessory buildings may be erected on a single lot of record at the effective date of adoption or amendment of this Ordinance and may be used for single family residence purposes. This provision shall apply even though such lot fails to meet the requirements for area or width, or both, that are generally applicable in the Zoning District; provided that yard dimensions and other requirements not involving area or width, or both, of the lot shall conform to the regulations for the district in which such lot is located. Yard requirement variances, if needed, must be granted by the Zoning Board of Appeals.

Any nonconforming lot of record, which also meets the definition herein of a Substandard Lot, shall comply with the yard and width requirements of Article XVIII - Schedule of Regulations

b. Contiguous Lots in Same Ownership

If two (2) or more lots or combination of lots and portions of lots with continuous frontage in single ownership are recorded at the time of passage or Amendment of this Ordinance, and if all or part of such lots do not meet the requirements of Article XVIII – Schedule of Regulations for lot width and area, the lands involved shall be considered to be a single undivided lot for building permit and all other purposes of this Ordinance, and no portion of said lot shall be used or sold in any manner which diminishes compliance with lot width, yard, and area requirements established by this Ordinance, nor shall any division of any lot be made which creates a lot width, yard or area less than the requirements stated in the Ordinance. These same provisions shall apply to platted and un-platted lots or parcels.

Except that, when two (2) or more abutting or contiguous lots (one or more of which is non-conforming in width or area) are of record and in single ownership as of the effective date of this Ordinance and each is occupied by a principal structure (as of the effective date of this Ordinance) the two (2) or more abutting lots shall be deemed as nonconforming lots of record under this Ordinance.

c. Contiguous Lots - Sale, Lease, Disposal or Development

If two (2) or more lots or combination of lots and portions of lots with continuous frontage in single ownership are recorded at the time of passage or amendment of this Ordinance, or are created subsequently, and if the sale, lease, disposal or development of one or more of said lot(s) would or has, in the judgment of the Building Official (or on appeal, in the judgment of the

Zoning Board of Appeals) create or has created a situation unsuitable to the public health, welfare or safety or would be contrary to the intent of the district, no Building Permit shall be issued until such situation has been corrected in the judgment of the Building Official. The intent of this Section is to avoid the creation of a situation where the location of existing driveways, walls, accessory buildings, principal buildings, off-street parking and similar features would not meet minimum yard requirements or would be located in part or entirely on a lot which would be in a different ownership. The further intent of this provision is to resolve existing and potential non-conformities or conflicts prior to the sale, lease, or disposal of contiguous lots in the same ownership to separate owners.

Section 5.06 - Reserved

Section 5.07 – Uses Under Special Approval Provisions Not Nonconforming Uses

Any use which exists at the time of adoption or amendment of this Ordinance, and which is listed as a Permitted Use After Special Approval in this Ordinance in the Zoning District in which such use is located, shall be deemed to be a conforming use.

Section 5.08 – Change of Tenancy or Ownership

There may be a change of tenancy, ownership or management of an existing nonconforming use of land or structure or combination thereof, provided there is no change in the nature or character of such nonconforming use.

Section 5.09 – Certificate of Occupancy for Nonconforming Uses

- a. At any time after the adoption of this Ordinance should the Village become aware of a nonconforming use, the owner of said nonconforming use shall be notified by the Village Clerk of the provisions of this Article, and that the use of his property constitutes a nonconforming use. Within thirty (30) days after receipt of said notice, the owner shall apply for and be issued a Certificate of Occupancy for the nonconforming use. The application for such Certificate shall designate the location, nature, and extent of the nonconforming use and such other details as may be necessary for the issuance of the Certificate of Occupancy.

If the owner of a nonconforming use fails to apply for a Certificate of Occupancy within thirty (30) days after receipt of the foregoing notice, the use ceases to be nonconforming and is hereby declared to be in violation of this Ordinance. The Village Clerk and the Village Attorney shall take appropriate action to enjoin such violation.

- b. If the Village Clerk shall find, upon reviewing the application for a Certificate of Occupancy, that the existing use is illegal or in violation of any other ordinance or law, or if the Village Clerk finds that the building for which the Certificate is requested has been constructed or altered for the existing use or any other use without full compliance with the Building Code or the Zoning Ordinance in effect at the time of construction or

alteration, the Certificate of Occupancy shall not be issued, but such use shall be declared in violation of this Ordinance.

- c. The Certificate of Occupancy issued by the Village Clerk for a nonconforming use shall state that the use may be continued indefinitely, subject to the requirements of this Article.

Section 5.10 – Record of Nonconforming Uses

The Village Clerk shall maintain a record of all known nonconforming uses of buildings and of land, including mobile and manufactured homes. Such record shall contain the names and addresses of the owners of record of such nonconforming use and of any occupant, other than the owner, the legal description of the land, and the nature and extent of use. Such list shall be available at all times in the office of the Village Clerk.

Section 5.11 – Reserved

Section 5.12 – Plans Already Filed

In any case where plans and specifications for a building or structure have been filed, which would conform with the zoning regulations effective at the date of such filing but not with the regulations of the Ordinance, and where a Building Permit for such building or structure has been issued and construction work started at the effective date of this Ordinance, such work may proceed provided it is completed within one (1) year of said date.

Section 5.13 – Removal of Nonconforming Uses and/or Structures

The Village Council may acquire by purchase, condemnation, or otherwise, private property containing a nonconforming use or structure, for the purpose of removal of said nonconforming uses and/or structures. The Council may, at its discretion, provide that the cost and expenses of such acquisitions and of the removal of nonconformity, less the probable resale price, be assessed to a benefit district. In assessing the costs and expenses, the Village Council shall also establish the assessment district, the properties to be assessed and a basis or formula for the distribution of the amount to be assessed against the benefited properties.

Section 5.14 – Nonconforming Use Determinations

This Section is intended to provide reasonable standards for determining whether a use is nonconforming, and whether a nonconforming use has been removed, discontinued or otherwise ceased to occupy the land or structure in question. When there is a question or dispute about the status of a particular use, such determinations shall be made in writing by the Building Official, with specific findings identified and a copy placed in the property file. Such determinations shall be subject to the following:

- a. Standards for Determining that a Use is Nonconforming

The Building Official shall determine that a use is nonconforming upon finding that the following three (3) statements are true:

1. The use does not conform with the purpose and use regulations of the Zoning District where it is located;
2. The use is in compliance with all other applicable federal, state, and local laws, Village ordinances, regulations and codes; and
3. Evidence from a minimum of three (3) of the following sources demonstrates that the use was lawfully established prior to the effective date of adoption or amendment of this Ordinance:
 - (a) Local, county or state government files or records, including but not limited to permits, inspection reports, dated photographs or notarized statements of government officials, agents, representatives or employees.
 - (b) Dated telephone directories, or similar dated records that provide information about the occupants or uses located on a street by address or lot number.
 - (c) Utility records, including but not limited to providers of water, sewer, electric, natural gas or telecommunications service.
 - (d) Dated advertising or other information published in a newspaper or magazine including but not limited to advertisements, articles, features or photographs that address the use of the land in question.
 - (e) Dated aerial photos from Oakland County, the Southeastern Michigan Council of Governments (SEMCOG) or other sources accepted by the Building Official.
 - (f) Other relevant information, including but not limited to date-stamped photographs, diary or log entries, affidavits or notarized statements.

b. Standards for Determining that a Nonconforming Use has been Abandoned

The Building Official shall determine that a nonconforming use has been removed, discontinued or otherwise ceased to occupy the land or structure in question upon finding that a minimum of three (3) of the following six (6) statements are true:

1. Local, county or state government files or records show that the nonconforming use has ceased. Such evidence may include, but shall not be limited to permits, inspection reports, dated photographs or notarized statements of government officials, agents, representatives or employees.
2. Dated telephone directories, or similar dated records that provide information about the occupants or uses located on a street by address or lot number show that

the nonconforming use has ceased. Such evidence may include, but shall not be limited to entries that show the address associated with the use as vacant or occupied by another use, or show the telephone number associated with the use as disconnected or in use at another location.

3. Utility records, including, but not limited to providers of water, sewer, electric, natural gas or telecommunications service, show that the nonconforming use has ceased. Such evidence may include, but shall not be limited to records indicating that the address of the use is vacant or occupied by another use, the utility service associated with the use has been disconnected or the business, organization or individual associated with the use has moved to another location.
4. Dated advertising or other information published in a newspaper or magazine show that the nonconforming use has ceased. Such evidence may include, but shall not be limited to advertisements, articles, features or photographs that address the use of the land in question.
5. Dated aerial photos from Oakland County, the Southeastern Michigan Council of Governments (SEMCOG) or other sources as accepted by the Building Official show that the nonconforming use has ceased.
6. Other relevant information shows that the nonconforming use has ceased. Such evidence may include, but shall not be limited to date-stamped photographs, diary or log entries, affidavits or notarized statements.

ARTICLE VI

OFF-STREET PARKING AND LOADING REQUIREMENTS

Section 6.01 – Off-Street Parking Required

- a. For every use, activity, or structure permitted by this Ordinance and for all buildings or structures erected in accordance therewith, there shall be provided sufficient space for access and off-street standing, parking, circulation, unloading, and loading for motor vehicles that may be expected to transport its users or occupants, whether as patrons, residents, customers, employees, guests, or otherwise, to an establishment, activity, or place of residence at any time under normal conditions for any purpose.

When a use is expanded, accessory off-street parking and loading shall be provided in accordance with the regulations herein for the area or capacity of such expansion in combination with the previously existing uses, structure, or activity. Existing off-street parking facilities actually being used on the effective date of this Ordinance, for the parking of automobiles in connection with the operation of an existing building or use shall not be reduced to an amount less than that hereinafter required for a similar new building or use unless additional parking facilities of the same amount are provided as described herein.

- b. **Area for Parking Space.** For the purpose of this Article, three hundred (300) square feet of lot area shall be deemed a parking space for one (1) vehicle, including access aisle, except that one hundred and eighty (180) square feet of lot area which has a direct means of ingress and egress from an alley or street may also be deemed a parking space.
- c. **Fractional Requirements.** When units or measurements determining the number of required parking spaces result in requirement of a fractional space, any fraction up to, and including one-half shall be disregarded and fractions over one-half shall require one (1) parking space.
- d. **Loading Space Limitations.** Loading space as required by this Article shall not be construed as providing off-street parking space.
- e. **Use of Parking Spaces.** Required off-street parking shall be for the use of occupants, employees, visitors, and patrons and shall be limited in use to motor vehicles. The storage of merchandise, motor vehicles for sale, wrecked or junked vehicles, trailers, mobile homes, travel homes, boats, boat trailers, the repair of vehicles or the creation of a junk yard or nuisance in such parking area is prohibited.
- f. **Single-Family Residential Uses.** Every single family residential dwelling shall provide on the same lot with such building, off-street parking facilities in the ratio of two (2) spaces for each dwelling unit. All parking shall be prohibited in the required front yard of any lot except on the driveway used for access to the required parking spaces.

- g. **Parking Facilities for Uses Other Than Single Family Residential.** The required off-street parking facilities for buildings used for other than single family residential purposes may be provided by one, or any combination of the following methods:
1. By providing the required off-street parking on the same lot as the permitted use being served.
 2. By providing the required off-street parking within three hundred (300) feet of the building being served, such distance to be measured along lines of public access to the property between the building to be served and the nearest point of the off-street parking facility.
 3. By the collective provisions of the required off-street parking for two (2) or more buildings or uses, provided that the total of such off-street parking area shall not be less than the sum of the requirements of the various buildings or uses, computed separately and that such parking areas are within three hundred (300) feet of the buildings being served, as provided above. Such parking may be provided either by individual action or by a parking program carried out through public action.
- h. **Uses Not Specifically Mentioned.** For those uses not specifically mentioned herein, the requirements for off-street parking facilities shall be interpreted by the Planning Commission from requirements for similar uses.
- i. **Change in Use of Parking.** Any area once designated as required accessory off-street parking shall never be changed to any other use unless and until off-street parking facilities are provided elsewhere in accordance with this Ordinance. Off-street parking existing at the effective date of this Ordinance shall not be reduced to an amount less than would herein after be required under the terms of this Ordinance.
- j. **Zoning of Accessory Parking.** All accessory parking facilities, whether provided in fulfillment of or in excess of the requirements of this Ordinance and whether located on the same or on a different lot from the principal use as provided herein, shall be located on property zoned within the same zoning district as the principal use served by such parking.
- k. **Joint Parking Facilities.** Off-street parking facilities for different building, structures, or uses, or for mixed uses, may be provided and used collectively or jointly in any Zoning District in which separate off-street parking facilities for each constituent use would be permitted, subject to the following provisions:
1. A written agreement assuring the perpetual joint usage of said common parking for the combination of uses or buildings is properly drawn and executed by the parties concerned, approved as to form and execution by the Village and Village Attorney, and filed with and made part of the application for a Building Permit.
 2. The parking spaces required for a theater or other place of evening entertainment, for a place of worship, or for a school may be provided and used jointly by banks,

offices, retail stores, repair shops, service establishments, and similar uses not normally open, used, or operated during evening hours if specifically approved by the Village.

- l. **Mixed Uses.** For building or land containing more than one (1) use, the total parking requirement shall be determined to be the sum of the requirements for each use.
- m. **Duty of Continuing Compliance.** Notwithstanding any transfer of the title to the real estate on which building or buildings are located, the transferees and occupants shall continue to maintain the off-street parking and loading area requirements of this Ordinance. It shall be unlawful for the owner or occupants of any building to discontinue or change, or cause the discontinuance or change of the required off-street parking without establishing, prior to such discontinuance or change, alternative off-street parking which meets the requirements of and is in compliance with this Ordinance.
- n. **Restriction of Parking on Private Property.** It shall be unlawful for any person, firm, or corporation to park any motor vehicle on any private property or use said private property for vehicle storage, or use any portion of any private property as parking space, without the express or implied consent, authorization, or ratification of the owner, holder, occupant, lessee, agent, or trustee of such property.
- o. **Exemption from Parking Requirements.** All existing buildings and uses established prior to the date of adoption of this Ordinance in the C-1 Village Commercial District shall be exempt from the requirements of this Article.
- p. In stadiums, sports arenas, places of worship, and other places of assembly in which patrons or spectators occupy benches, pews, or other similar seating facilities, each twenty-four (24) inches of such seating facilities shall be counted as one (1) seat for the purpose of determining requirements for off-street parking facilities under this Article.

Section 6.02 – Off-Street Parking Requirements

The minimum number of required off-street parking spaces for new uses or buildings, additions thereto, and additions to existing buildings as specified above shall be determined in accordance with the following table, and the space so required shall be stated in the application for a building permit and shall be irrevocably reserved for such use and/or shall comply with the initial part of this Section.

USE		NUMBER OF OFF-STREET PARKING SPACES PER EACH UNIT OF MEASURE
a.	RESIDENTIAL	
1.	Single Family Dwellings.	Two (2) per dwelling unit.
2.	Multiple Family Dwellings.	Two (2) per dwelling unit or one (1) per efficiency dwelling unit.

USE		NUMBER OF OFF-STREET PARKING SPACES PER EACH UNIT OF MEASURE
3.	Boarding, Rooming, Lodging Establishments, Tourist Homes, and/or Bed and Breakfast Inns.	One (1) for each sleeping room plus one (1) for each non-resident employee.
4.	Multi-Family Senior Citizen Housing.	One (1) for each dwelling unit plus one (1) for each employee. Should such units revert to general occupancy, then parking spaces shall be provided as indicated for multiple family dwellings, above.
5.	Mobile Home Parks.	Two (2) for each mobile home site, either on street or off-street; plus one (1) visitor parking space for three (3) mobile home sites.
6.	Foster Care Facility, State Licensed Residential Facility, Family Child Care Home and Group Child Care Home	One (1) for each non-resident employee, plus one (1) for each three (3) beds.
b.	INSTITUTIONAL	
1.	Places of Worship and similar places of Public Assembly having fixed seating	One (1) per three (3) seats or six (6) lineal feet of benches or pews in the main unit of assembly
2.	Private Clubs, Lodge Halls, Assembly Halls, Exhibition Halls and similar places of Public Assembly not having fixed seating	One (1) per each three (3) persons allowed within a maximum occupancy as established by Fire, Building, or Health Codes.
3.	Theaters and Auditoriums (indoor).	One (1) per each three (3) seats plus one (1) additional for each two (2) employees.
4.	Nursery Schools, Child Care Centers and Private Schools or Schools for Special Education.	One (1) for each employee, plus two (2) per classroom. Plus auditorium if applicable.
5.	Nursing Homes, Convalescent Homes, Orphanages, Children's Homes, Special Group Housing and similar institutional uses for care of the young, ill, aged or impaired	One (1) for each four (4) beds, plus one (1) for each staff or visiting doctor, plus one (1) for each employee, including nurses.
6.	Hospitals.	One (1) for each patient bed, plus one (1) additional for every five (5) workers employed during the eight (8) hour shift in which the greatest number of employees are on duty, plus one (1) for each ten (10) doctors on the hospital staff.
7.	Stadium, Sports Arena, or similar place of outdoor assembly.	One (1) for each three (3) seats or six (6) feet of benches.

USE		NUMBER OF OFF-STREET PARKING SPACES PER EACH UNIT OF MEASURE
8.	Libraries, Museums, Non-Commercial Art Galleries, or similar facilities	One (1) for each 400 square feet of gross floor area plus one (1) per employee on the largest shift.
9.	Golf Courses open to the public except Miniature or "Par 3" Courses.	Six (6) for each one (1) golf hole and one (1) for each one (1) employee.
10.	Private Golf Clubs, Tennis Clubs, Swimming Pool Clubs or other similar uses	One (1) for every two (2) member families or each individual member.
11.	Elementary, Junior High and Intermediate Schools	One (1) for each teacher, administrator, or other employee in addition to the requirements of the auditorium. If there is no auditorium or assembly hall, then two (2) per classroom shall be provided in addition to those for each teacher, administrator, or employee.
12.	Senior High Schools.	One (1) for each one (1) teacher, administrator, and one (1) for each ten (10) students, in addition to the requirements of the auditorium.
13.	Industrial or Vocational Schools including Commercial Schools, Business, Business Machine and Computer Technology Schools.	One (1) for each two (2) students. Additional parking shall be provided to accommodate any retail sales or service activities conducted.
c.	OFFICES	
1.	General Tenant Offices, Professional Offices of Lawyers, Architects, Engineers, Urban Planners, and similar professions.	One (1) for each 200 sq. ft. of usable floor area.
2.	Offices of Doctors, Dentists, and similar Practitioners, and Medical and Dental clinics.	One (1) for each 100 sq. ft. of usable floor area
d.	RETAIL SALES OR SERVICES	
1.	Retail Stores, except as otherwise specified herein.	One (1) for each 150 sq. ft. of usable floor area.
2.	Clustered Commercial or Retail Shopping Centers	One (1) for each 125 sq. ft. of usable floor area.
3.	Furniture and Major Appliance, Household Equipment, Personal Service Shops (other than Barber and Beauty Shops), Repair Shops, Showroom of a Plumber, Decorator, Electrician or similar trade, Shoe Repair and other similar uses.	One (1) for each 800 sq. ft. of usable floor area, exclusive of that floor area used for processing. One (1) additional shall be provided for each two (2) persons employed therein.

USE		NUMBER OF OFF-STREET PARKING SPACES PER EACH UNIT OF MEASURE
4.	Laundromats and Coin-Operated Cleaning Establishments.	One (1) for each two (2) washing or dry cleaning machines.
5.	Banks and similar financial institutions.	One (1) for each 200 sq. ft. of usable floor area.
6.	Barber and Beauty Shops.	One (1) for each employee and/or service operator, plus two (2) for each service chair.
7.	Bowling Alleys.	Five (5) per alley plus such additional spaces as are required for restaurants, bars, assembly rooms, and affiliated facilities.
8.	Automobile Service and Filling Stations.	Two (2) for each service bay, and one (1) for each gasoline pump or one (1) per 3,000 sq. ft. of lot area, whichever is greater.
9.	Auto Washes.	One (1) for each employee. In addition, stacking spaces equal in number to five (5) times the maximum capacity of the auto wash shall be "maximum capacity" shall mean the greatest number possible of automobiles undergoing some phase of washing at the same time, which shall be determined by dividing the length of each wash line by twenty (20) feet.
10.	Auto Repair, Auto Body Repair, Buffing, and/or Collision.	One (1) per bay plus one (1) per each employee on the peak shift.
11.	Mortuary Establishment	One (1) for each fifty (50) sq. ft. of assembly room, parlor and slumber room usable floor area.
12.	Indoor Recreation Facilities, Athletic Clubs, Physical Exercise Establishments, Skating Rinks, Court Recreation, Health Studios Sauna Baths, and similar uses.	One (1) per each three (3) patrons based on max occupancy as established by local, county or state fire, building or health codes, whichever is greater, plus (1) per employee at peak shift: plus such spaces as required for affiliated uses such as bar, restaurant, etc.
13.	Outdoor Recreation Facilities such as Athletic, Swimming, Tennis, or similar uses	One (1) per each potential patron plus one (1) per peak shift employee; plus such spaces as may be required for any indoor facility.
14.	Restaurants	
(a)	Dining room, including Banquet areas.	One (1) per sixty five (65) sq. ft. of usable floor area.
(b)	Bar/Lounge	One (1) per fifty (50) sq. ft. of usable floor area.
(c)	Fast Food Restaurant	One (1) per thirty (30) sq. ft. of usable floor area.

USE		NUMBER OF OFF-STREET PARKING SPACES PER EACH UNIT OF MEASURE
(d)	Carry-Out Restaurant	One (1) per eighty (80) sq. ft. of usable floor area or six (6), whichever is greater.
(e)	Drive-In or Drive-Up Restaurant.	One (1) per thirty (30) sq. ft. of usable floor area plus ten (10) stacking spaces for each drive-up transaction station
15.	New Motor Vehicle Sales, Rental, and Service Establishments, Trailer Sales and Rental; Boat Showrooms	One (1) for each 400 sq. ft. of floor area exclusive of the service area, plus one (1) for each vehicle service stall in the service room, plus one (1) per employee on the largest shift.
16.	Used Motor Vehicle Sales	One (1) for every 500 sq. ft. of outdoor sales area plus one (1) for each auto service stall, plus one (1) per employee on the largest shift.
17.	Pool Room, Billiard Parlor, and Table Game Establishments.	Either one (1) per pool table, billiard table, or game, plus one (1) for every twenty (20) sq. ft. of floor area, or one (1) per every three (3) persons based on the occupancy load as established by Local, County, and State Fire, Building, and Health codes, whichever is greater.
18.	Open Air Businesses, including Plant Nurseries.	One (1) per 500 sq. ft. of land area being utilized for sales or rental purposes plus one (1) per employee.
19.	Retail Lumber Yards and Grain Elevators.	One (1) for each employee on the largest shift, plus one (1) for each 150 sq. ft. of enclosed retail sales area.
20.	Self-Service Storage Facility (Mini-Warehouse)	One (1) for every forty (40) storage cubicles, plus two (2) for each manager's quarters.
21.	Motel, Hotel, or Other Commercial Lodging Establishments.	One (1) for each one (1) occupancy unit plus one (1) for each one (1) employee, plus extra for dining rooms, ballrooms, or meeting rooms, based upon maximum load.

e.	INDUSTRIAL AND WAREHOUSE	
1.	Wholesale, Storage and Warehousing Establishments.	One (1) for each one (1) employee in the largest working shift or one (1) for each 2,000 sq. ft. of gross floor area, whichever is greater. Any retail or service area shall be in addition to the above.
2.	Contractor's Yards and Heavy Equipment Storage Yard, Non-Retail Lumber and Building Materials Yard, Motor Freight Terminal.	One (1) per employee on the largest shift, plus one (1) per stored vehicle, plus sufficient spaces to accommodate the largest number of visitors that may be expected at any one time, but with a minimum of one (1) per 1,000 sq. ft. of gross floor area.
3.	Manufacturing Establishment or Establishment for Production, Processing, Assembly, Compounding, Preparation, Cleaning, Servicing, Testing, Repair, or Storage of Materials, Goods or Products.	One and one half (1.5) per employee on the largest shift.
4.	Junk Yards.	One (1) for each employee at peak shift, plus one (1) for each acre of storage area used or planned.

Section 6.03 - Reserved

Section 6.04 – Off-Street Parking Space Layout, Standards, Construction and Maintenance

Wherever a parking lot is built as required off-street parking, such parking lot shall be designed, constructed, and maintained in accordance with the following standards and regulations.

- a. The building of a parking lot is subject to the requirements for Article XXV – Site Plan Approval. The Building Official in reviewing the application may request the findings of the Village Engineer on the basis of the requirements, set forth below.
- b. Proof of any necessary permits or approvals from the Road Commission of Oakland County or other agency with jurisdiction shall accompany any application.
- c. All parking facilities shall not be less than the following minimum requirements (see illustration entitled “Parking Layouts”):

Parking Pattern	Maneuvering Lane Width	Parking Space Width	Parking Space Length	Total Width of One Tier of Spaces Plus Maneuvering Lane	Total Width of Two Tier of Spaces Plus Maneuvering Lane
0 degrees (parallel parking)	12 ft	8 ft	23 ft.	20 ft.	28 ft.
30 to 53 degrees	12 ft.	9 ft.	20 ft.	32 ft.	52 ft.
54 to 74 degrees	15 ft.	9 ft.	20 ft	36 ft. 6 in	58 ft.
75 to 90 degrees	20 ft.	9 ft.	20 ft.	40 ft	60 ft.

- d. Except for parallel parking, all parking spaces shall be clearly striped to facilitate movement and to help maintain an orderly and efficient parking arrangement.
- e. Off-street parking reserved for the handicapped shall be provided in accordance with the State Construction Code and the following table and identified by signs bearing the international symbol for the handicapped as being reserved for physically handicapped persons. A maximum of two (2) spaces may be designated by a single sign when the sign displays arrows specifically delineating each space. Signs shall be installed approximately seven (7) feet above grade. Each reserved parking space shall not be less than twelve (12) feet in width, or eight (8) feet in width if a five (5) foot wide access aisle is provided. Where a curb exists between a parking lot surface and a sidewalk surface, an inclined approach or a curb cut with a gradient of not more than one (1) foot in twelve (12) feet and a width of not less than four (4) feet shall be provided for wheelchair access. Parking spaces for the physically handicapped shall be located as close as possible to walkways and entrances. Signs shall be provided when necessary indicating the direction of travel to an accessible entrance.

Barrier-free parking spaces shall be provided per the State Construction Code and the following:

Number of Parking Spaces Provided	Minimum Number of Barrier-Free Spaces Required	Van Accessible Parking Spaces Required	Accessible Parking Spaces Required
Up to 25	1	1	0
26 to 50	2	1	1

Number of Parking Spaces Provided	Minimum Number of Barrier-Free Spaces Required	Van Accessible Parking Spaces Required	Accessible Parking Spaces Required
51 to 75	3	1	2
76 to 100	4	1	3
101 to 150	5	1	4
151 to 200	6	1	5
201 to 300	7	1	6
301 to 400	8	1	7
401 to 500	9	2	7
501 to 1,000	2% of total parking provided in each lot	1 out of every 8 accessible spaces	7 out of every 8 accessible spaces
1,001 and over	20 plus 1 per 100 spaces over 1,000	1 out of every 8 accessible spaces	7 out of every 8 accessible spaces

- f. Stacking spaces for drive-through and other uses shall be a minimum of ten (10) feet wide and twenty (20) feet in length; shall not extend into any public street right-of-way and shall be distinctly separated from on-site parking so as not to interfere with ingress and egress to parking spaces.
- g. All parking lots shall have clearly limited and defined access from roadways and said access shall not be less than twenty-four (24) feet in width at the right-of-way line. Interior driveways shall also be clearly defined and not less than twelve (12) feet wide for one-way and twenty (20) feet wide for two-way traffic. Except for permitted parallel parking spaces, all parking spaces shall have access from an aisle on the site. Backing directly onto a street shall be prohibited.
- h. Parking spaces shall be set back from abutting residential districts as follows:
 - 1. Where the parking lot abuts on side or rear lot lines, the required setback shall be ten (10) feet from said lot lines.
 - 2. Where the parking lot abuts on a contiguous common frontage in the same block, the required setback shall be equal to the residential required setback, or average of existing setbacks in the common block frontage, whichever is greater.
 - 3. Where the parking lot is across the street and opposite, with residential lots fronting on such streets, the required setback shall be equivalent to the opposite residential required setback.
- i. Parking, loading areas, and access drives shall be no closer to any building or structure than five (5') feet. Bumper Guards shall be installed to prevent encroachment.

- j. The Village may require the posting of such traffic control signs, as it deems necessary to promote vehicular and pedestrian safety.
- k. Bumper stops, curbing, or wheel stops shall be provided and so located as to prevent any vehicle from damaging or encroaching upon any required wall, berm, sidewalk, bike path or landscaping, upon any building adjacent to the parking lot, or upon any adjacent property. Freeway-type guardrails shall be prohibited.
- l. All lighting used to illuminate any off-street parking area shall be limited to no more than fourteen (14) feet in height and so installed, maintained, and directed as to have no adverse effect upon adjacent properties.
- m. Grading and Drainage. Driveways and parking areas shall be graded and provided with adequate drainage to dispose of surface waters in accordance with applicable construction and design standards established by the Village. Surface water shall not drain onto adjoining lots, towards buildings or across a public road, except in accordance with an approved drainage plan.
- n. The off-street parking facilities in all non-single family residential districts shall be covered with asphalt or concrete surfacing in accordance with Village standards. The parking lot shall be drained to eliminate surface water.
- o. In order to insure pedestrian safety, sidewalks, of not less than five (5) feet in width, may be required to separate any driveway or parking area from a building and also along the right-of-way line of all abutting streets.
- p. An approved parking or loading facility that is not maintained in accordance with the provisions of the approved site plan shall be considered in violation of this Ordinance.
- q. All parking areas, perimeter landscaped areas, and required screening shall be kept free from tall grass, weeds, trash, and debris.

Section 6.05 – Parking Lot Landscaping and Screening

- a. For those uses requiring greater than twenty (20) parking spaces, there shall be a minimum of twenty-five (25) square feet of landscaping for each space in excess of twenty (20) spaces required, and a minimum of two hundred (200) square feet of landscaping must be provided.
- b. Whenever a parking lot adjoins residential property and/or a residential street or alley, an ornamental, uniformly colored solid masonry or brick wall five (5) feet in height shall be erected and maintained between the lot line and the area to be used for parking. A greenbelt or dense hedge may be permitted by the Village in lieu of a wall.

Section 6.06 - Reserved

Section 6.07 – Off-Street Loading and Unloading

On the same premises with every building, structure, or part thereof, erected or occupied for manufacturing, storage, warehousing, retailing, display or other such similar uses involving the receipt or distribution of vehicles or materials or merchandise, there shall be provided and maintained on the lot adequate space for standing, loading and unloading services adjacent to the opening used for loading and unloading designed to avoid interference with public use of the streets or alleys.

All such loading and unloading areas, including all access drives, shall be paved and shall be in addition to the required off-street parking area requirements.

Such loading and unloading space, unless otherwise adequately provided for, shall be an area twelve (12) feet in width by fifty (50) feet with a fifteen (15) foot height clearance and shall be provided according to the following table:

Gross Floor Area in Square Feet	Loading and Unloading Spaces Required in Terms of Square Feet of Gross Floor Area_
0 to 2,000	None
2,001 to 20,000	One (1) space
Over 20,000	One (1) plus one (1) for each 20,000 sq. ft. in excess of 20,000 square feet.

No loading space may be on any street frontage and provision for handling all freight shall be on those sides of any building which do not face any street or proposed street

No loading space shall be located closer than fifty (50) feet from any residentially zoned district or use unless located on an alley, within a completely enclosed building, or enclosed on all sides facing a residential zoning district or use by a solid masonry wall or ornamental fence of a type approved by the Planning Commission not less than six (6) feet in height.

Section 6.08 – Parking Layouts

All off-street parking shall be designed in conformity with the following parking layouts. (See illustration entitled “Parking Layouts.”)

PARKING LAYOUTS

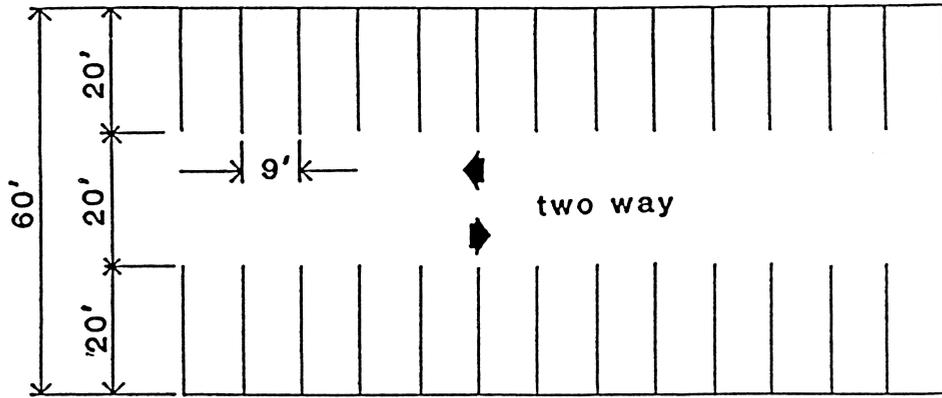

75 to 90 degrees

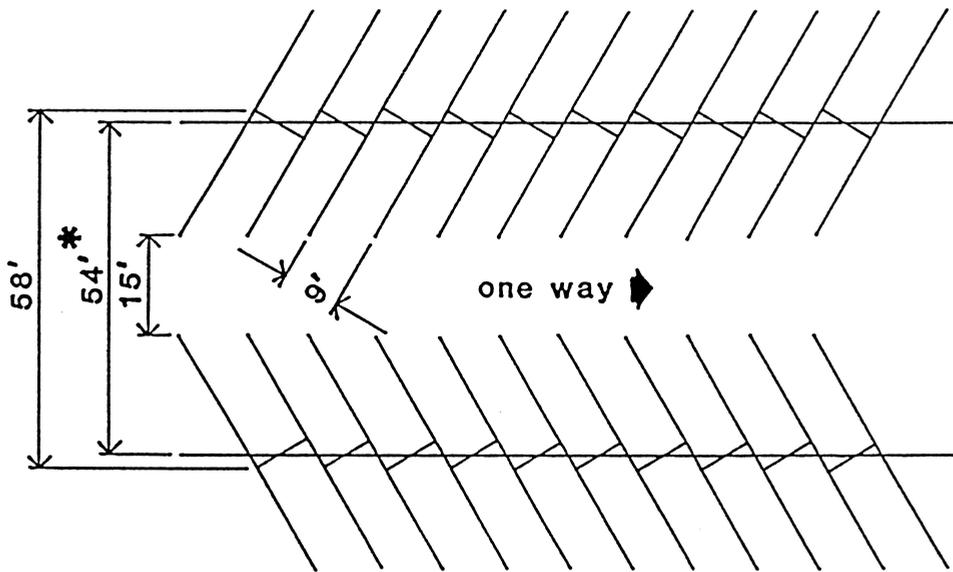

54 to 74 degrees

* Overlapping dimension (including herringbone pattern)

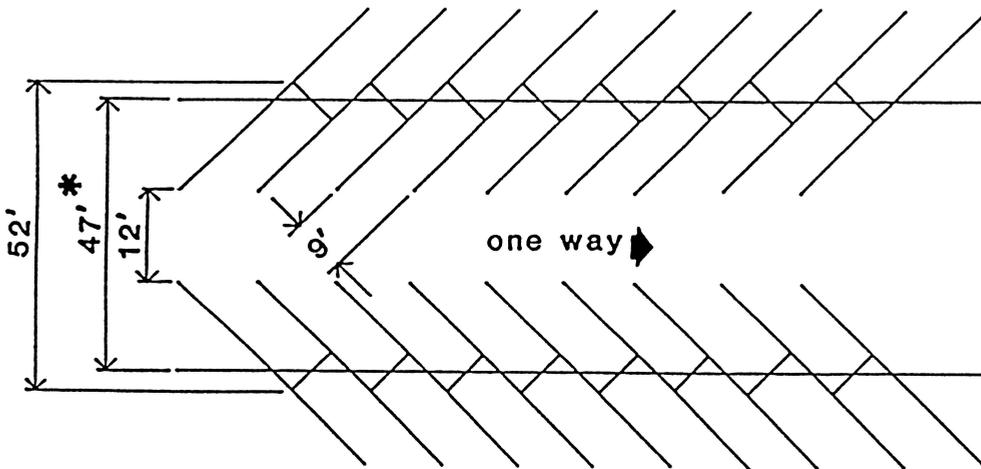

30 to 53 degrees

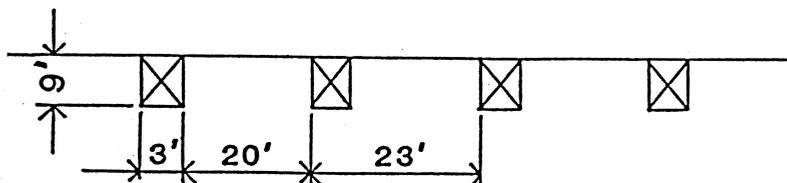

Parallel

ARTICLE VII

PERFORMANCE STANDARDS

Section 7.01 – Intent and Scope of Application.

- a. **Intent.** The purpose of this Article is to establish controls on the impacts generated by permitted uses so as to prevent an unreasonable negative impact that might interfere with another person’s use of his or her property, or that might cause harm to the public health, safety, and welfare.

- b. **Scope of Application.** After the effective date of this Ordinance, no structure or tract of land shall hereafter be used or occupied, and no structure or part of thereof, shall be erected, altered, reconstructed, or moved, except in conformity with all applicable performance standards set forth in this Article. No Site Plan shall be approved unless evidence is presented to indicate conformity with the requirements of this Article.

- c. **Submission of Additional Data.** Nothing in this Article shall preclude the applicant or other interested party from submitting additional data or evidence related to a specific case. In consideration of such data or evidence, the Planning Commission may waive or modify the regulations set forth in this Article, provided that the Planning Commission finds that no harm to the public health, safety, and welfare will result and that the intent of this Ordinance will be upheld.

Section 7.02 – Performance Standards.

No activity, operation, or use of land, buildings, or equipment shall be permitted if such activity, operation, or use does not conform to the following standards, which standards are established as the minimum requirements to be maintained.

- a. **Noise.**
 - 1. **Noise Disturbances Prohibited.** No persons shall unreasonably make, continue, or cause to be made or continued, any noise disturbance. Examples of noise disturbances include, but are not limited to:

Sounds Which Exceed Limits in Table A. Any sound, which exceeds the limits, set forth in Table A, below, shall be deemed a Noise Disturbance.

Loading and Unloading. Loading and unloading, opening, closing, or other handling of boxes, crates, containers, building materials, garbage cans, or similar objects shall be prohibited between the hours of 8:00 pm and 7:00 am in such a manner as to cause a noise disturbance across a residential district boundary or within a noise sensitive zone.

Construction. Operation of any tools or equipment used in construction, drilling, or demolition work shall be prohibited between the hours of 9:00 pm and 7:00 am

on weekdays or any time on Sundays or holidays, such that the sound there from creates a noise disturbance across a residential district boundary or within a noise sensitive zone, except for emergency work of public service utilities.

Vibration. Operating of any device that creates vibration, which is above the vibration perception threshold of an individual, at or beyond the property of the source, shall be prohibited. For the purposes of this Section, “vibration perception threshold” means to cause a normal person to be aware of the vibration by such direct means as, but not limited to, sensation by touch or visual observation of moving objects.

Noise Sensitive Zones. Creating of any sound within any noise sensitive zone so as to disrupt the activities normally conducted within the zone shall be prohibited, even if the average A-weighted sound level is lower than the values shown in Table A, below, provided that conspicuous signs are displayed indicating the presence of the zone.

2. **Exceptions.**

Emergency Exceptions. The provisions in this Section shall not apply to (a) the emission of sound for the purpose of alerting persons to existence of an emergency, or (b) the emission of sound in the performance of emergency.

Additional Exceptions. The provisions in this Section shall not apply to the following activities, provided that such activities are conducted in a legally-accepted manner:

- Snow plowing, street sweeping, and other public works activities.
- Agricultural uses.
- Church bells, chimes, and carillons.
- Lawn care and house maintenance that occurs between 8:00 am & 9:00 pm.
- Licensed vehicles being operated on a road or street.
- Trains and aircraft when on the ground.

3. **Variances.**

An Application for a variance from the provisions in this Section may be submitted to the Zoning Board of Appeals. The owner or operator of equipment on the property shall submit a statement regarding the effects of sound from the equipment on the overall sound level in the area. The statement shall include a study of the background sound levels, predicted level on sound at the boundary line due to the proposed operation, and justification for the variance. Upon review of the request for a variance, the Zoning Board of Appeals may grant a variance where strict adherence to the permitted sound level would create unnecessary hardship and only if the variance will not create a threat to the health, safety, and welfare of the public. The Zoning Board of Appeals may impose conditions of operation when granting a variance.

4. **Maximum Permitted Sound Levels by Receiving Zoning District.**

Sound emitted by any source is considered a Noise Disturbance when its average A-weighted sound level exceeds the limit set forth for the receiving zoning district in Table A, when measured at or within the property boundary of the receiving district.

Table A

Maximum Permitted Average A - Weighted Sound Levels

Receiving Zoning District	Time	Average Sound Level, db(A)
Residential	7:00 a.m. to 10:00 p.m.	55
Residential	10:00 p.m. to 7:00 a.m.	50
Commercial	7:00 a.m. to 6:00 p.m.	62
Industrial	6:00 p.m. to 7:00 a.m.	55

Notes:

Correction for Tonal Sounds. For any source of sound, which emits a pure tone sound, the maximum sound level limits in Table A shall be reduced by 5 db(A) where the receiving district is residential or commercial – noise sensitive.

Correction for Impulsive or Impact-Type Sounds. For any source of sound, which emits an atypical impulsive or impact-type sound, the maximum sound level limits in Table A shall be reduced by 5 db(A) where the receiving district is residential or commercial-noise sensitive.

5. **Permitted Land Use.**

No new or substantially modified structure shall be approved for construction unless the owner or developer of such land demonstrates that the completed structure and the activities associated with and on the same property as the structure will not generate a Noise Disturbance as set forth in this Section at the full-scale operation of such activities.

b. **Dust, Smoke, Soot, Dirt, Fly Ash, and Products of Wind Erosion.**

Dust, smoke, soot, dirt, fly ash, and products of wind erosion shall be subject to the regulations established in conjunction with the Air Pollution Act, Michigan Public Act 348 of 1965, as amended, or other applicable state or federal regulations. The drifting of air-borne matter beyond the lot line, including wind-blown dust, particles or debris from open stock piles, shall be prohibited. Emission of particulate matter from materials,

products, or surfaces subject to wind erosion shall be controlled by paving, oiling, wetting, covering, landscaping, fencing, or other means.

c. **Odor.**

Offensive, noxious, or foul odors shall not be allowed to escape into the atmosphere in concentrations which are offensive, which produce a public nuisance or hazard on adjoining property, or which could be detrimental to human, plant, or animal life.

d. **Glare and Heat**

Any operation or activity which produces glare shall be conducted so that direct and indirect illumination from the source of light does not exceed one-half (1/2) of one (1) foot-candle when measured at any point along the property line of the site on which the operation is located. Any operation, which produces intense glare or heat, shall be conducted within an enclosure so as to completely obscure and shield such operation from direct view from any point along the lot lines. If heat is a result of an industrial operation, it shall be so insulated as to not raise the temperature at any property line at any time.

e. **Gases**

The escape of or emission of any gas which is injurious or destructive to life or property, or which is explosive, is prohibited. Gaseous emissions shall be subject to regulations established in conjunction with the Air Pollution Act, Michigan Public Act 348 of 1965, as amended, the Federal Clean Air Act of 1963, as amended, and any other applicable state or federal regulations. Accordingly, gaseous emissions measured at the property line at ground level shall not exceed the levels indicated in the following chart, which is based on the National Ambient Air Quality Standards, unless a higher standard is imposed by a Federal, state, county or local regulatory agency which has jurisdiction:

Gas	Maximum Emissions Level	Sampling Period
Sulfur dioxide	0.14 ppm	24 hour
Hydrocarbons	0.24 ppm	3 hour
Photochemical oxidants	0.12 ppm	1 hour
Nitrogen dioxide	0.05 ppm	annual
Carbon monoxide	9.0 ppm	8 hours
Carbon monoxide	35.0 ppm	1 hour
Lead	1.5 ug/cubic meter	3 months
Mercury	0.01 mg/cubic meter	10 hours
Beryllium	2.0 ug/cubic meter	8 hours
Asbestos	0.05 fibers/cc	8 hours

Section 7.03 – Procedures for Determining Compliance.

In the event that the Village receives complaints or otherwise acquires evidence of possible violation of any of the performance standards set forth in this Article, the following procedures shall be used to investigate, and if necessary, resolve the violation:

- a. **Official Investigation.** Upon receipt of evidence of possible violation, the Building Official shall make a determination whether there is reasonable cause to suspect the operation is indeed in violation of the Performance Standards. The Building Official may initiate an official investigation in order to make such a determination.

Upon initiation of an official investigation, the Building Official is empowered to require the owner or operator of the facility in question to submit data and evidence deemed necessary to make an objective determination regarding the possible violation. Failure of the owner or operator to supply requested data should constitute grounds for taking legal action to terminate the use and/or deny or cancel any permits required for continued use of the land. Data which may be required includes, but is not limited to the following:

1. Plans of the existing or proposed facilities, including buildings and equipment.
2. A description of the existing or proposed machinery, processes, and products.
3. Specifications for the mechanisms and techniques used or proposed to be used to control emissions regulated under the provisions of this Article.
4. Measurement of the amount or rate of emissions of the material purported to be in violation.

- b. **Method and Cost of Determination.** The Building Official shall take measurements and complete investigation necessary to make an objective determination concerning the purported violation. Where required measurements and investigation can be accurately made by the Building Official using equipment and personnel normally available to the Village without extraordinary expense, such measurements and investigation shall be completed before notice of violation is issued. If necessary, skilled personnel and specialized equipment or instruments shall be secured in order to make the required determination.

If the alleged violation is found to exist in fact, the costs of making such determination shall be charged against those responsible, in addition to such other penalties as may be appropriate. If it is determined that no substantive violation exists, then the costs of this determination shall be paid by the Village.

- c. **Notice of Violation.** If, after appropriate investigation, the Building Official determines that a violation does exist, the Building Official shall issue a Notice of Violation to the responsible individual(s) and shall take or cause to be taken lawful action as provided by this Ordinance to eliminate such violation.

d. **Appropriate Remedies.** Upon receipt of a Notice of Violation, the individual(s) deemed responsible shall take appropriate action in accordance with the following:

1. **Correction of Violation within Time Limit.** If the alleged violation is corrected with the specified time limit, even if there is no reply to the notice, the Building Official shall note “Violation Corrected” on the Village’s copy of the notice, and the notice shall be retained on file. If necessary, the Building Official may take other action as may be warranted by the circumstances of the case, pursuant to regulations in this and other Ordinances.
2. **Violation Not Corrected and No Reply from Owner or Operator.** If there is no reply from the owner or operator within the specified time limits (thus establishing violation, as provided in this Section), and the alleged violation is not corrected in accordance with the regulations set forth in this Article, then the Building Official shall take such action as may be warranted to correct the violation.
3. **Reply Requesting Extension of Time.** If a reply is received within the specified time limit indicating that an alleged violation will be corrected in accordance with the regulations set forth in this Ordinance, but that more time is required than was granted by the original notice, the Building Official may grant an extension if:
 - (a) The Building Official deems that such extension is warranted because of the circumstances in the case; and
 - (b) The Building Official determines that such extension will not cause imminent peril to life, health, or property.
4. **Reply Requesting Technical Determination.** If a reply is received within the specified time limit requesting further review and technical analysis even though the alleged violations continue, then the Building Official may call in properly qualified experts to complete such analysis and confirm or refute the initial determination of violation.

If expert findings indicate that violations of the Performance Standards do exist in fact, the costs incurred in making such a determination shall be paid by the individual(s) responsible for the violations, in addition to such other penalties as may be appropriate under the terms of this Ordinance. Such costs shall be billed to the individual(s) who are deemed responsible for the violation. If the bill is not paid within thirty (30) days, the Village shall take whatever appropriate action is necessary to recover such costs, or alternately, the cost shall be charged against the property where the violation occurred. If no substantial violation is found, cost of determination shall be paid by the Village.

e. **Continued Violation.** If, after the conclusion of the time period granted for compliance, the Building Official finds that the violation still exists, any permits previously issued shall be void and the Village shall initiate appropriate legal action, including possibly pursuit of remedies in a Court of Law.

- f. **Appeals.** Action taken by the Building Official pursuant to the procedures outlined in this Section may be appealed to the Zoning Board of Appeals with thirty (30) days following said action. In the absence of such appeal, the Building Official's determination shall be final.

ARTICLE VIII

ZONING DISTRICTS AND MAP

Section 8.01 – Establishment of Districts

The Village of Leonard is hereby divided into Zoning Districts known as follows:

DISTRICT:	ABBREVIATION	PAGE (Zoning Ordinance)
Single – Family Residential District	(R-1, R-2)	9-1
Multiple – Family Residential District	(MD)	10-1
Manufactured Home Park District	(MHP)	11-1
Agricultural District	(AG)	12-1
Small Farm District	(R-1F)	13-1
Village Commercial District	(C-1)	14-1
Limited Industrial District	(LI)	15-1
Park and Recreation District	(PR)	17-1

Section 8.02 – Zoning Map

The boundaries of these Zoning Districts are shown upon the map attached hereto and made a part of this Ordinance, which map is designated as the Zoning Map of the Village of Leonard. The Zoning Map attached hereto and on file in the office of the Clerk of the Village of Leonard and all notations, references, and other information shown thereon are a part of this Ordinance and have the same force and effect as if said Zoning Map and all such notations, references, and other information shown thereon were fully set forth or described herein.

Except where references on said Map to a street or other designated line by the dimensions shown on said Map indicate otherwise, the district boundary lines follow lot lines or the center lines of the street or alley rights-of-way or such lines extended and the corporate limits of Village of Leonard as existing at the time of the adoption of this Ordinance.

Section 8.03 – Interpretation of Boundaries

All questions concerning the exact location of boundary lines of the districts shall be determined by the Zoning Board of Appeals, according to the Rules and Regulations which may be adopted

by the Zoning Board of Appeals. The Zoning Board of Appeals may also base its determination in such matters upon the nearest established line or boundary consistent with the carrying into effect of the policies established in this Ordinance.

Section 8.04 – Alteration of Zoning Districts

No change shall be made to the Zoning Map of the Village of Leonard, as described in Section 8.02 hereof, unless and until such change shall first have been approved by the Council of the Village of Leonard after recommendation by the Planning Commission, and in accordance with the amendment procedures set forth in the Michigan Zoning Enabling Act, Public Act 110 of 2006, as amended, and this Ordinance.

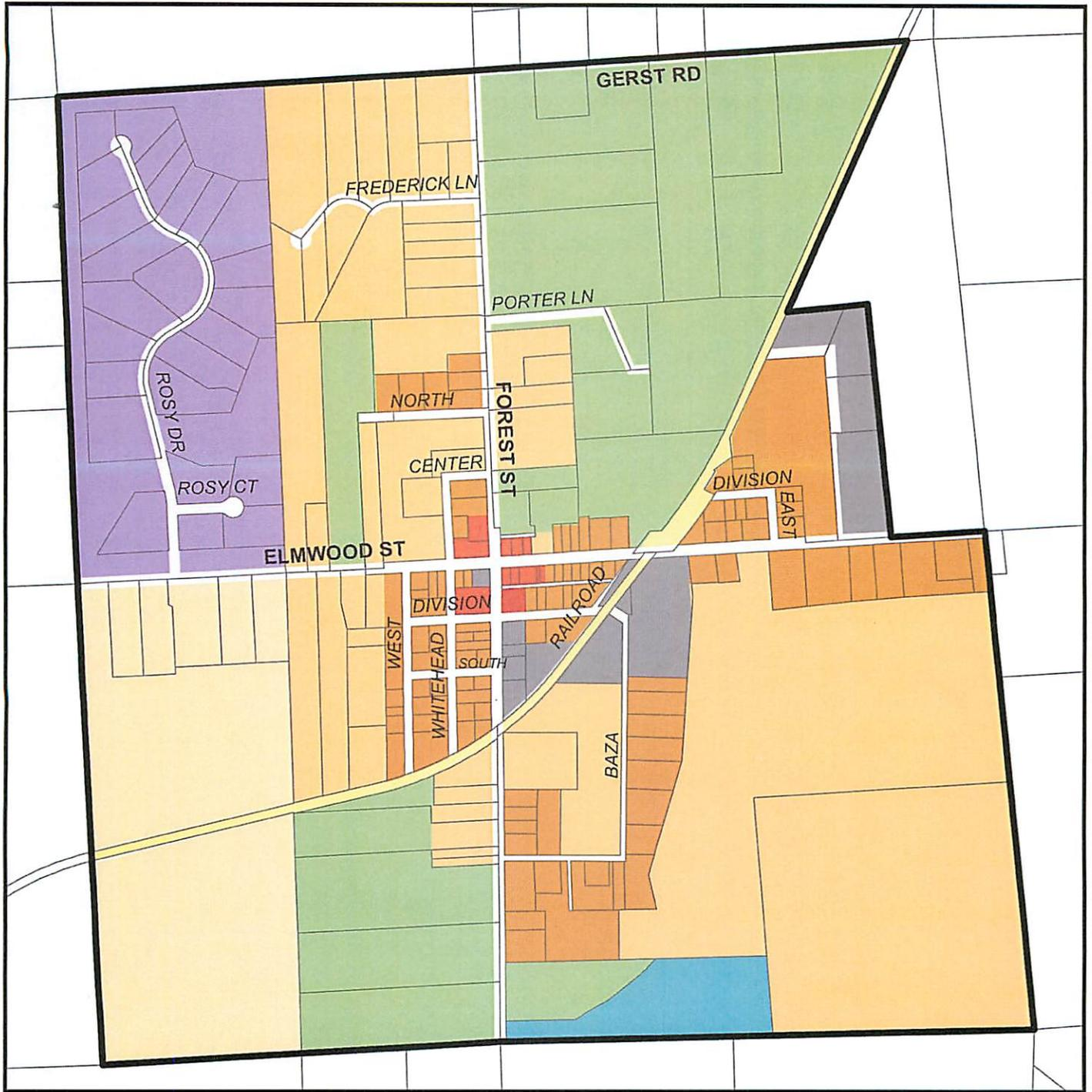

WHERE PEOPLE & TECHNOLOGY PROSPER
Oakland County Michigan
 L. Brooks Patterson, County Executive

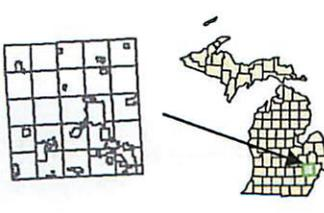

Village of Leonard Zoning Map

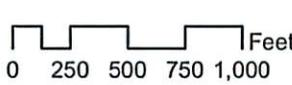
 Feet
 0 250 500 750 1,000

Date: 1/11/2012



Legend

- AG Agricultural
- R-1F Small Farm
- R-1 Single Family Residential
- R-2 Single Family Residential
- MD Multiple Family
- C Village Commercial
- LI Light Industrial
- PUD Planned Unit Development
- Right of Way

ARTICLE IX

R-1 and R-2 - SINGLE FAMILY RESIDENTIAL DISTRICTS

Section 9.01 – Statement of Purpose

The Single Family Residential Districts are established as Zoning Districts in which the principal use of land is for single family dwellings, but each district having different minimum lot areas to permit differing development character and densities. For these Residential Districts, in promoting the general purpose of this Section, the specific intent of this Section is:

- a. To permit the construction of, and the continued use of the land for single-family dwellings; and
- b. To prohibit business, commercial or industrial use of the land, and to prohibit any other use, which would substantially interfere with development, or continuation of single family dwellings, in the district; and
- c. To encourage the discontinuance of existing uses that would not be permitted as new uses under the provisions of this Ordinance; and
- d. To discourage any land use, which would generate traffic on minor or local streets, other than normal traffic, to serve the residences on those streets; and
- e. To discourage any use which, because of its character or size would create requirements and costs or public services, such as fire and police protection, and water supply, substantially in excess of such requirements and costs if the district were developed solely for single family dwellings.

Section 9.02 – Permitted Principal Uses

In the R-1 and R-2 Districts, the following uses shall be permitted:

- a. Single Family Detached Dwellings.
- b. Family Child Care Homes subject to the Standards of this Ordinance and the Regulations in Section 206 of Michigan Public Act 110 of the Public Act of 2006, MCL 125.3206, as amended.
- c. State Licensed Residential Facilities that provide resident services for six (6) or fewer persons under 24-hour supervision or care including Foster Care Facilities, subject to the regulations in Section 206 of Michigan Public Act 110 of the Public Act of 2006, MCL 125.3206, as amended.
- d. Accessory buildings and uses customarily incidental to the above Principal Permitted Uses.

- e. Off-street parking accessory to the above Principal Permitted Uses in accordance with the requirements of Article VI - Off Street Parking and Loading Requirements.

Section 9.03 – Permitted Uses after Special Approval

The following uses shall be permitted subject to the conditions hereinafter imposed and subject further to the approval of the Village Council, in accordance with the procedures, requirements and standards set forth in this Section and in Article XXVI - Special Approval.

- a. Places of Worship subject to the following conditions:
 - 1. Unless established prior to the enactment of this Ordinance, a place of worship site shall contain an area of at least two (2) acres.
 - 2. The site shall be so located as to have at least one (1) property line abutting a major thoroughfare. All ingress and egress to the site shall be directly onto said major thoroughfare.
 - 3. Wherever the off-street parking area is adjacent to land zoned for residential purposes, a continuous and obscuring wall not less than five (5) feet in height or a landscape buffer strip shall be provided along the sides of the parking area adjacent to the residentially zoned land in accordance with Article IV - General Provisions.
- b. Cemeteries, subject to the following conditions:
 - 1. Unless established prior to the enactment of this Ordinance, the cemetery site shall contain an area of at least twenty (20) acres.
 - 2. The site shall be so located as to have at least one (1) property line abutting a major thoroughfare. All ingress and egress to the site shall be directly onto said thoroughfare.
 - 3. The perimeter of the site shall be fenced in accordance with Article IV - General Provisions.
 - 4. Any structure located on the site shall be at least one hundred (100) feet from any lot line.
 - 5. Compliance with applicable state laws regulating the use of cemeteries.
- c. Public utility buildings, telephone exchange buildings, electric transformer stations and substations, and gas regulator stations, subject to the following conditions:
 - 1. Such uses shall be permitted only when location in residential areas is required to serve the immediate vicinity.
 - 2. No outside service or storage yards shall be permitted.

3. All structures shall be at a scale and have an exterior appearance compatible with a residential area.
 4. All lines serving such sites shall be underground. Overhead transmission lines and tower structures are expressly prohibited.
- d. Public recreation uses such as municipal parks, swimming pools, playgrounds, and community centers, not including outside storage area.
 - e. Municipal, State or Federal uses, public libraries, public museums, provided that no outside services or storage yards shall be permitted.
 - f. Public, parochial and other private elementary or secondary schools offering courses in general education and not operated for profit, subject to the following conditions:
 1. No building shall be closer than fifty (50) feet to any property line when said property line abuts or is adjacent to land zoned or used for residential purposes.
 2. All vehicular access shall be only from a paved public street.
 3. All buses shall be stored off-site.
 4. All parking and circulation shall be paved in accordance with the off-street parking standards of this Ordinance.
 - g. Nursery schools, day nurseries and child care centers (not including dormitories) provided that for each child so cared for, there shall be provided and maintained a minimum of seven-hundred (700) square feet of outdoor play area. Such play space shall be screened from any adjoining lot in any residential district in accordance with Article IV - General Provisions. All vehicular access shall be only from a paved public street.
 - h. Tourist homes and bed and breakfast inns, subject to the following requirements:
 1. The owners or operators shall be permanent residents of such in which shall remain as a single family home in appearance and shall have no internal or external structural alterations. An example would be no enlargement of the kitchen for volume food service.
 2. Off-street parking shall be provided for the household and guests in accordance with Article VI – Off Street Parking and Loading Requirements of this Ordinance.
 3. There shall be ample open space other than that required to accommodate the required off-street parking. Natural screening by use of plant material or other screening may be required to screen parking areas from adjoining residential properties. Off-street parking in front yard areas shall not be permitted.
 4. Food may be served only to those persons renting a room only during their stay.

5. The inn shall not have, or be converted to, more rental rooms than the number of bedrooms that exist at the time of enactment of this Ordinance. The maximum number of rooms that may be rented at one time shall not exceed five (5).
 6. There shall be no signs except that one (1) wall sign not to exceed a total area of eight (8) square feet shall be permitted for identification purposes only.
 7. The lot shall have at least one (1) property line abutting a paved public street. All ingress and egress to the lot shall be directly onto said street.
- i. Group Child Care Homes subject to the Standards of this Ordinance and the regulations in Section 206 of Michigan Public Act 110 of the Public Act of 2006, MCL 125.3206, as amended.
1. The group child care home is not located closer than one-thousand and five-hundred (1,500) feet to any of the following:
 - (a) Another licensed group child care home.
 - (b) Another licensed adult-foster care small group home or large group home.
 2. Appropriate fencing for the safety of the children in the group child care home is provided in accordance with the requirements of Article IV – General Provisions.
 3. The lot location shall be such that at least one (1) property line abuts a major thoroughfare. The ingress and egress for off-street parking areas of residents, employees, and guests shall be directly from said thoroughfare.
 4. The group child care home facility shall not be injurious to the use and enjoyment of other property in the immediate vicinity for the purposes permitted, nor substantially diminishes or impair property values within the neighborhood.
 5. The principal and accessory buildings shall be a minimum of one hundred (100) feet from any residential structure in the district.
 6. The group child care home facility shall meet all applicable requirements of the Michigan Department of Human Services.

Section 9.04 – Reserved

Section 9.05 – Area, Height, Bulk and Placement Requirements

Area, height, bulk, and placement requirements, unless otherwise specified, are as provided in Article XVIII- Schedule of Regulations.

Section 9.06 – Site Plan Review

In accordance with Article XXV - Site Plan Review, with the exception of permitted principal agricultural uses and single family detached residential uses, a site plan shall be required for all principal and special approval uses permitted in this District.

Section 9.07 – Environmental Impact Assessment

- a. An environmental impact assessment, in accordance with Article XXV - Site Plan Review, may be required by the Planning Commission or the Village Council.
- b. All required environmental impact assessments shall be furnished by the applicant at the applicants' sole expense.

ARTICLE X

M-D - MULTIPLE FAMILY RESIDENTIAL DISTRICT

Section 10.01 – Statement of Purpose

The M-D Multiple-Family Residential District is designed to permit more intensive residential use of land. The M-D District shall provide for two-family residences, multiple housing, and mobile home park developments. The Multiple-Family District shall abut a major thoroughfare for good accessibility and may be located between single-family residential areas and non-residential uses. It is intended that various sizes of residential accommodations, for ownership and rental, shall be provided to meet the needs of the community.

Section 10.02 – Permitted Principal Uses

In the Multiple Family Residential District, the following uses shall be permitted:

- a. Multiple family dwellings of a low-rise type, including but not limited to: apartment houses, row houses, terraces, townhouses and attached dwelling units.
- b. Two-family dwellings.
- c. Single-family dwellings.
- d. Family Child Care Homes subject to the standards of this Ordinance and the regulations in Section 206 of the Michigan Public Act 110 of the Public Act of 2006, MCL 125.3206, as amended.
- e. State Licensed Residential Facilities that provide resident services for six (6) or fewer persons under 24 hour supervision or care, including Foster Care Facilities, and the regulations in Section 206 of the Michigan Public Act 110 of the Public Act of 2006, MCL 125.3206, as amended.
- f. Maintenance and management buildings to serve multiple dwellings
- g. Community garages to serve the principal residential dwellings.
- h. Uses or structures accessory to the above Principal Permitted Uses.
- i. Off street parking accessory to the above Principal Permitted Uses in accordance with the requirements of Article VI - Off Street Parking and Loading Requirements.

Section 10.03 – Permitted Uses after Special Approval

The following uses shall be permitted subject to the conditions, hereinafter imposed and subject further to the approval of the Village Council, in accordance with the procedures, requirements and standards set forth in this Section and in Article XXVI - Special Approval.

- a. Places of Worship subject to the following conditions:
1. Unless established prior to the enactment of this Ordinance, a Place of Worship site shall contain an area of at least two (2) acres.
 2. The site shall be so located as to have at least one (1) property line abutting a major thoroughfare. All ingress and egress to the site shall be directly onto said major thoroughfare.
 3. Wherever the off-street parking area is adjacent to land zoned for residential purposes, a continuous and obscuring wall not less than five (5) feet in height or a landscape buffer strip shall be provided along the side of the parking area adjacent to the residentially zoned land in accordance with Article IV – General Provisions.
- b. Cemeteries, subject to the following conditions:
1. Unless established prior to the enactment of this Ordinance, the cemetery shall contain an area of at least twenty (20) acres.
 2. The site shall be so located as to have at least one (1) property line abutting a major thoroughfare. All ingress and egress to the site shall be directly onto said major thoroughfare.
 3. The perimeter of the site shall be fenced in accordance with Article IV – General Provisions.
 4. Any structure located on the site shall be at least one hundred (100) feet from any lot line.
 5. Compliance with applicable state laws regulating use of cemeteries.
- c. Public utility buildings, telephone exchange buildings, electric transformer stations and substations, and gas regulator stations, subject to the following conditions:
1. Such uses shall be permitted only when location in residential areas is required to serve the immediate vicinity.
 2. No outside service or storage yards shall be permitted.
 3. All structures shall be at a scale and have an exterior appearance compatible with a residential area.
 4. All lines serving such sites shall be underground. Overhead transmission lines and tower structures are expressly prohibited.
- d. Public recreation uses such as parks, swimming pools, playgrounds, and community centers, not including outside storage areas

- e. Municipal, state, or federal uses, public libraries, public museums, provided that no outside service or storage yards shall be permitted.
- f. Public, parochial, and other private elementary, intermediate, and/or high schools offering courses in general education, subject to the following conditions:
 - 1. No building shall be closer than fifty (50) feet to any property line when said property line abuts or is adjacent to land zoned or used for residential purposes.
 - 2. All vehicular access shall be only from a paved public street.
 - 3. All buses shall be stored off-site.
 - 4. All parking and circulation shall be paved in accordance with the off-street parking standards of this Ordinance.
- g. Nursery schools, day nurseries and child care centers (not including dormitories) provided that for each child so cared for, there shall be provided and maintained a minimum of seven hundred (700) square feet of outdoor play area. Such play space shall be screened from any adjoining lot in any residential district in accordance with Article IV – General Provisions. All vehicular access shall be only from a paved public street.
- h. Colleges, universities, and other such institutions of higher learning, public and private, offering courses in general, technical, or religious education, provided no building other than a structure for residential purposes shall be closer than fifty (50) feet to any property line which abuts or is adjacent to land zoned or used for residential purposes.
- i. Group Child Care Homes, subject to the standards of this Ordinance and the regulations in Section 206 of the Michigan Public Act 110 of the Public Act of 2006, MCL 125.3206, as amended.
 - 1. The group child care home is not located closer than one-thousand and five-hundred (1,500) feet to any of the following:
 - (a) Another licensed group child care home.
 - (b) Another licensed adult-foster care small group home or large group home.
 - 2. Appropriate fencing for the safety of the children in the group child care home is provided in accordance with the requirements of Article IV – General Provisions.
 - 3. The lot location shall be such that at least one (1) property line abuts a major thoroughfare. The ingress and egress for off-street parking areas of residents, employees, and guests shall be directly from said thoroughfare.
 - 4. The group child care home facility shall not be injurious to the use and enjoyment of other property in the immediate vicinity for the purposes permitted, nor substantially diminish or impair property values within the neighborhood.

5. The principal and accessory buildings shall be a minimum of one hundred (100) feet from any residential structure in the district.
 6. The group child care home facility shall meet all applicable requirements of the Michigan Department of Human Services.
- j. Foster care small group home and/or foster care group home, subject to the following:
1. The lot location shall be such that at least one (1) property line abuts a major thoroughfare. The ingress and egress for off-street parking areas of residents, employees, and guests shall be directly from said thoroughfare.
 2. Concentrations of such facilities shall be avoided.
 3. The foster care facility shall not be injurious to the use and the enjoyment of other property in the immediate vicinity for the purposes permitted, nor substantially diminish or impair property values within the neighborhood.
 4. The principal and accessory buildings shall be a minimum one hundred (100) feet from any residential structure in the district.
 5. The foster care facility shall meet all applicable requirements of the Michigan Department of Human Services.
- k. Housing for the elderly not to exceed a height of one (1) story, when following conditions are met:
1. All housing for the elderly shall be provided as planned development consisting of at least one (1) acres and shall provide for: common services, including, but not limited to: central dining rooms, recreational rooms, central lounge and workshops.
 2. All dwelling units shall consist of at least three hundred and fifty (350) square feet per unit (not including kitchen and sanitary facilities).
 3. The maximum density of development shall not exceed fifteen (15) dwelling units per gross acre and total coverage per gross acre shall not exceed twenty-five (25) percent for all buildings (including dwelling units and related service buildings).
 4. Off-street parking shall be provided on the site in an amount equal to one (1) space per dwelling unit.
- l. Tourist homes and bed and breakfast inns, subject to the following requirements:
1. The owners or operators shall be permanent residents of such inn, which shall remain as a single-family home in appearance and shall have no internal or external structural alterations. An example would be no enlargement of the kitchen for volume food service.

2. Off-street parking shall be provided for the household and guests in accordance with Article VI – Off Street Parking and Loading Requirements.
3. There shall be ample open space other than that required to accommodate the required off-street parking. Natural screening may be required to screen parking areas from adjoining residential properties. Off-street parking in front yard areas shall not be permitted.
4. Food may be served only to those persons renting a room only during their stay.
5. The inn shall not have, or be converted to, more rental rooms than the number of bedrooms which exist at the time of enactment of this Ordinance. The maximum number of rooms that may be rented at one time shall not exceed five (5).
6. There shall be no signs except that one (1) wall sign not to exceed a total area of eight (8) square feet shall be permitted for identification purposes only.
7. The lot shall have at least one (1) property line abutting a paved public street. All ingress and egress to the lot shall be directly onto said street.

Section 10.04 – Site Development Standards for Multiple Family Developments

a. Multiple Family and Single Family Attached Residential Requirements

Multiple Family and Single Family Attached Residential development standards shall vary, dependent upon whether or not the units have attached, private garages. The following site development standards shall apply to attached housing developments in the Multiple Family Districts:

1. **Building Length.** Multiple family buildings shall not exceed one hundred and fifty (150) feet in overall length, measured along the front line of connecting units, inclusive of any architectural features which are attached to or connect the parts of the building together.
2. **Building Spacing.** The minimum distance between any two (2) buildings shall be based on the length and height of the buildings, in accordance with the following:

BUILDING TYPE	SIDE SEPARATION	REAR SEPARATION	SIDE TO REAR SEPARATION
1 and 2 story	30 feet	80 feet	60 feet
2.5 story	40 feet	100 feet	60 feet

The minimum distance between any two adjacent building planes shall be measured at the closest (most narrow) points between the two buildings. If there is a

combination of 1-, 2- and/or 2.5 story buildings in the same development, the minimum distance requirements shall be based on the higher of the two buildings. In no instance, shall there be less than thirty (30) feet between any two adjacent buildings. The thirty (30) foot minimum separation also applies to buildings with corner-to-corner relationships.

3. **Street Address.** The address of each dwelling unit must be clearly posted so that the unit can be readily identified from the roadway or adjacent parking area.
4. **Access and Circulation.** Multiple family developments shall comply with the following requirements for access and circulation.
 - (a) **Access to Roads.** Multiple family development shall only have access to a paved existing or planned road with a right-of-way greater than sixty (60) feet; however, alternate means of access may be permitted by the Planning Commission upon finding that, due to special circumstances substantial improvements in traffic safety could be achieved by reducing the number of driveways.
 - (b) **Emergency Access.** All dwelling units, including those under construction, shall be readily accessible by fire and emergency vehicles from a paved public street, paved private access road, or other approved paved area. Private roadways dedicated as fire lanes shall be posted with signs indicating “Fire Lane, No Parking.” To facilitate emergency vehicle access, the following guidelines shall be complied with:
 - (1) All roadways shall be paved and bi-directional, allowing for both ingress and egress. A boulevard may be utilized to provide bi-directional traffic movement, provided that the median strip is a minimum of twenty-five (25) feet in width.
 - (2) Streets with no outlet shall be terminated with a cul-de-sac, designed in accordance with standards established and periodically updated by the Village Engineer and kept on file with the Village Clerk. Such streets with no outlet shall not exceed seven hundred (700) feet in length or one thousand (1,000) feet in length for developments having a minimum lot size of one (1) acre or density of one (1) dwelling unit/acre or less.
 - (3) Gatehouses and/or barricades at entrances to private roadways shall be designed so as not to impede fire and emergency vehicle access.
 - (c) **Street Dimensions.** On-site streets and drives shall have a minimum width as follows:
 - (1) Boulevard with median: fifteen (15) foot moving lane in each direction (measured back of curb).

- (2) Undivided two-way street or drive, without parking: twenty-four (24) feet (measured back of curb).
- (3) Undivided two-way street or drive with parallel parking: forty-one (41) feet (measured back of curb).

5. **Sidewalks.**

- (a) Sidewalks shall be provided within developments where units do not have private attached garages. Such sidewalks shall provide convenient access to community buildings and between parking areas and dwelling units. Required sidewalks shall be no less than five (5) feet in width. Sidewalks shall be placed not less than three (3) feet from the edge of the curb of an access drive. The areas between the sidewalk and curb shall be seeded or sodded with grass, and shade trees shall be planted in the area.
- (b) Developments with private, attached garages shall provide an internal pedestrian path system instead of sidewalks parallel to the internal streets to minimize conflicts with driveway crossings and vehicular traffic. The internal path system shall be a minimum of five (5) feet in width and constructed of asphalt or concrete, with an appropriate base. Where the pedestrian path passes through wooded or wetland areas, it may be constructed of gravel or wood chip mulch.

6. **Parking/Garages/Driveways.** Multiple Family Developments shall comply with the following requirements:

- (a) **Location.** Required parking shall be located in parking lots or individual driveways, and not in streets or access drives. Parking may be permitted in required side and rear yard setback areas provided that parking lots and access drives shall be located a minimum of fifteen (15) feet from any property line or public right-of-way.
- (b) **Distance from Dwelling Units.** Parking shall be located within one hundred and fifty (150) feet of the dwelling units the parking is intended to serve, measured along the sidewalk leading to the parking lot.
- (c) **Guest Parking.** Guest parking shall be provided for all Multiple Family and Single Family Attached Residential units, at the rate of no less than one (1) per three (3) units.
- (d) **Parking for Community Buildings.** Parking shall be provided for community buildings

7. **Lighting.** All parking areas, building entrances, sidewalks, and ramps shall be illuminated to ensure the security of property and the safety of persons using such areas in accordance with this Ordinance.

8. **Landscaping.** Multiple family developments shall be landscaped in accordance with this Section
9. **Open Space.** Open spaces shall be provided in any multiple family development containing eight (8) or more units, the open space shall comply with the following requirements:
 - (a) **Size.** Total open space required shall be based on the number and size of units, as indicated in the following chart, provided that each development shall contain a minimum of ten thousand (10,000) square feet of open space, or three-hundred (370) square feet per unit, whichever is greater.
 - (b) **Location.** Open space shall be located conveniently in relation to the majority of dwelling units intended to be served. Wetland areas, storm-water detention, marshy areas, and similar limited-use areas shall not be included in the required open space.
 - (c) **Use of Open Space.** Uses permitted within the required open space include picnic and sitting areas, playground and park space, play equipment, tennis courts, shuffleboard courts, and similar outdoor recreation facilities.
 - (d) **Phasing.** Open space improvements shall be completed in proportion to the number of units constructed in each phase.
10. **Antennae.** Each multiple family building shall be permitted to erect one (1) antenna.
11. **Dumpsters.** Dumpsters and outside storage shall comply with Article IV – General Provisions.

b. Landscaping Requirements for Multiple-Family Districts

In addition to the General Landscaping Requirements set forth in Article IV - General Provisions, all lots or parcels of land located in M-D Zoning Districts shall comply with the following landscaping requirements:

1. **General site Landscaping.** A minimum of two (2) deciduous or evergreen trees, plus, four (4) shrubs shall be planted per dwelling unit. Unless otherwise specified, required landscaping elsewhere in the multiple-family development shall not be counted in meeting these requirements for trees.
2. **Landscaping Variety.** In order to encourage creativity in landscaping and to minimize tree loss caused by species-specific disease, a variety of tree species shall be required.
3. **Parking Lot Landscaping.** Multiple family uses requiring off street parking areas containing greater than fifteen (15) spaces shall be provided with at least

fifteen (15) square feet of interior landscaping per parking space, excluding those parking spaces abutting a public right-of-way or buffer zone for which landscaping is required by the various provisions of this Ordinance, and also excluding all parking spaces which are directly served by a driveway abutting and running parallel to a public right-of-way or buffer zone. Whenever possible, parking lot landscaping shall be designed to improve the safety of pedestrian and vehicular traffic, guide traffic movement, and improve the appearance of the parking area. Interior landscaping shall comply with all applicable requirements set forth in Article IV - General Provisions. Required landscape areas shall be a minimum of two hundred (200) square feet and contain a minimum of one (1) tree.

4. **Protective Screening Requirements.** Protective screening in the form of a berm or an obscuring wall shall be required wherever development in an M-D District abuts directly upon land zoned for residential or agricultural purposes. Berms shall be minimum four (4) feet in height, and shall be planted in accordance with Article IV - General Provisions. If a wall is used instead of a berm the requirements of Article IV - General Provisions shall be complied with.
5. **Privacy Screen.** Where multiple family dwellings are designed so that rear open areas or patio areas front onto a public street, a landscaped privacy screen shall be provided. Such screen may consist of a combination of trees, shrubs, and berming, subject to review by the Planning Commission.
6. **Landscaping Adjacent to Roads.** The front side, or rear yards adjacent to roads shall be landscaped in accordance with the following standards:

A minimum of one (1) deciduous and one (1) evergreen tree shall be planted for each forty (40) lineal feet or portion thereof of road frontage, plus, a minimum of one (1) ornamental tree shall be planted for each eighty (80) lineal feet or portion thereof of road frontage, plus, a minimum of one (1) shrub shall be planted for each ten (10) lineal feet or portion thereof of road frontage. Dwarf species of shrubs may be utilized at a rate of one and one-half (1.5) times the base shrub requirement. For the purposes of computing length of road frontage, openings for driveways and sidewalks shall not be counted. Trees may be planted at uniform intervals, at random or in groupings. Shrubs must be planted in masses of at least five (5).

Section 10.05 – Area, Height, Bulk and Placement Requirements

Area, height, bulk, and placement requirements, unless otherwise specified, are as provided in Article XVIII - Schedule of Regulations.

Section 10.06 – Site Plan Review

In accordance with Article XXV - Site Plan Review, with the exception of permitted principal agricultural uses and single family detached residential uses, a Site Plan shall be required for all principal and Special Approval uses permitted in this District.

Section 10.07 – Environmental Impact Assessment

- a. An environmental impact assessment, in accordance with Article XXV - Site Plan Review, may be required by the Planning Commission or the Village Council.
- b. All required environmental impact assessments shall be furnished by the applicant at the applicants' sole expense.

ARTICLE XI

MHP - MANUFACTURED HOME PARK DISTRICT

Section 11.01 – Intent

The MHP Manufactured Home Park District is intended to provide for the location and regulation of manufactured home parks. It is intended that manufactured home parks, or mobile home parks as they are sometimes known, be provided with necessary community services in a setting that provides a high quality of life for residents. These Zoning Districts should be located in areas where they will be compatible with adjacent land uses. It is further the intent of this district to prohibit office, business, commercial, or industrial use of the land.

Section 11.02 – Statutory Provisions

Regulations established by state law and the Michigan Manufactured Housing Commission Rules govern all manufactured home parks in the Village. When regulations in this Article exceed the state law or the Michigan Manufactured Housing Commission Rules, the higher standards of this Ordinance are intended to insure that manufactured home parks meet the development and to promote the health, safety, and welfare of the Village's residents. The higher standards incorporated herein have been approved by the Michigan Manufactured Housing Commission in accordance with the Manufactured Housing Commission's requirements

Section 11.03 – Permitted Uses and Structures

In all areas zoned MHP, Manufactured Home Park District, no building shall be erected, used, or structurally altered, nor shall the land or premises be used in whole or in part, except for one or more of the following principal uses.

- a. Mobile Home/Manufactured Home Parks after preliminary Site Plan Review and approval as specified in these provisions.
- b. Multiple family dwellings, subject to site development standards in Article X - Multiple Family Residential District.
- c. Essential services, subject to the other related definitional and use provisions of this Ordinance.
- d. Family Child Care Homes subject to the standards of this Ordinance and the regulations in Section 206 of Michigan Public Act 110 of the Public Act of 2006, MCL 125.3206, as amended.
- e. State Licensed Residential Facilities that provide resident services for six (6) or fewer persons under 24-hour supervision or care including Foster Care Facilities, subject to the regulations in Section 206 of Michigan Public Act 110 of the Public Act of 2006, MCL 125.3206, as amended.

- f. Uses and structures accessory to the above, subject to the provisions in this Article. Permitted accessory uses and structures include, but are not necessarily limited to parks, open space, and recreation facilities for the use of residents and their guests, one (1) office building for the exclusive purpose of manufactured home park business; utility and storage buildings for use of residents; garages and carports; and signs.

Section 11.04 – Permitted Uses after Special Approval

Uses indicated below may be permitted in the MHP District, subject to review and approval by the Village Council in accordance with the Special Use Approval procedures established in this Ordinance.

- a. Municipal buildings and municipal uses which do not require outside storage of materials or equipment.

Section 11.05 – Reserved

Section 11.06 – Development Standards

- a. **Preliminary Site Plan Review.**

Preliminary plans shall be submitted to the Village for review by the Planning Commission, prepared in accordance with this Article. Article XXV - Site Plan Review of this Ordinance shall not apply to the MHP District. The plans shall include the location, layout, general design, and description of the project. The preliminary plan requirement of this Ordinance does not include detailed construction plans.

In preparing the preliminary plan and when reviewing the plan, the following procedures and requirements shall apply, except where said procedures and requirements are superseded by the Manufactured Housing Commission Rules.

- 1. **Application Filing.**

Any person requesting any action or review under the provisions of this Ordinance shall file an application on the forms provided by the Village. The information required should be typed or legibly written on the form or on separate sheets attached to the form. Not less than seventeen (17) copies of the preliminary plan shall accompany the form.

- 2. **Required Information.**

The following required information should be included on all preliminary plans:

- (a) Name of development and general location sketch.
- (b) Name, address, and phone number of owners(s), developer, and designer. Date drawn and revision dates shall be indicated on the site plan.

- (c) A legal description and address of the property in question.
- (d) Boundary dimensions (to the nearest foot) of the property clearly indicated on the site plan differentiated from other contiguous property.
- (e) Existing zoning classification of the parcel.
- (f) Adjacent land uses and zoning, and if the parcel is part of a larger parcel, boundaries of total land holding.
- (g) To facilitate determination of off-street parking needs and similar matters, the applicant shall indicate the name and nature of the uses proposed to occupy the accessory building(s) if this has been determined, or shall indicate cases where exact occupancy has not yet been determined.
- (h) All plans shall include a north arrow and scale.
- (i) The area of the site excluding all existing and proposed public right-of-way.
- (j) The minimum dimensions of typical home site.
- (k) The location and dimension of all existing and proposed structures on the property and all existing structures within one hundred (100) feet of the subject property. Proposed manufactured homes need not be shown.
- (l) The location and widths of all abutting streets and alleys, and driveways.
- (m) Traffic and pedestrian circulation patterns, and the proposed location and dimensions of sidewalks.
- (n) Parking lots including layout and typical dimensions of parking spaces, number of spaces provided (including how computed, per Ordinance requirements) and type of surfacing.
- (o) Preliminary location of well and sewage treatment facilities.
- (p) If proposed location and dimensions of rubbish storage areas and screening construction.
- (q) Easements for public right-of-way, utilities, access, shared access, and drainage.
- (r) Notation of any variances which have been or must be secured.
- (s) Landscaping plan indication location, types of trees and sizes of material. A landscaping maintenance plan for pruning, mowing, watering, fertilizing, and replacement of dead and diseased materials. A typical cross section of any berms shall be provided.

- (t) The dimensions and locations of all signs and lighting structures.
- (u) The location of any outdoor storage of material(s) and the manner in which it shall be screened or covered.
- (v) Location and dimensions of all wetland areas.

3. Processing and Review.

Applications accepted by the Village shall be submitted, along with authorized review fees, to appropriate Village staff and consultants for their written reviews and recommendations. The application shall be submitted along with all recommendations to the Planning Commission. Official receipt of the application is the time the complete application and plan arrives or is delivered to the office of the Building Official.

The staff may advise and assist the applicant in meeting Ordinance requirements but shall have no power to approve or disapprove any application or in any way restrict an applicant's right to seek formal approval thereof.

4. Planning Commission Action.

The Planning Commission shall review all applications at a Public Meeting. The Planning Commission may consider all recommendations of the staff and consultants. The Planning Commission shall take action on the preliminary plan within sixty (60) days after the Village officially receives a completed application with a complete plan along with authorized fees paid. All applications that the Planning Commission has been charged with the authority to approve under the provisions of this Ordinance shall be approved, denied, or approved subject to conditions. The Planning Commission may table an application for further study or to obtain additional information, provided that final action is taken within the sixty (60) day review period.

The following criteria shall be used by the Village Planning Commission as a basis upon which preliminary plans will be reviewed. The Village shall adhere to sound planning principles, yet may allow for design flexibility in the administration of the following standards:

- (a) The preliminary site plan shall be harmoniously and efficiently designed in relation to the topography, size, and type of land, and the character of the adjacent properties and the proposed use.
- (b) The existing natural landscape shall be preserved in its natural state as much as possible, by minimizing tree and soil removal and by topographic modifications that result in maximum harmony with adjacent properties. Detailed grading plan and topographic survey shall not be required.

- (c) There shall be reasonable visual and sound privacy. Fences, walls, barriers, and landscaping shall be used, as appropriate, for the protection and enhancement of property and the safety and privacy of occupants and users. The Planning Commission shall be guided in their review of the preliminary plan by the Landscaping and Screening provisions of this Article.
- (d) All buildings or groups of buildings shall be so arranged as to permit convenient and direct emergency vehicle access in accordance with the requirements of this Article.
- (e) Where possible and practical, drainage design shall recognize existing natural drainage patterns.
- (f) Exterior lighting shall be subject to the requirements of the Manufactured Housing Commission and be arranged and limited in intensity and height so that it is deflected away from adjoining properties and so that it does not impede vision of drivers along adjacent streets.
- (g) Adequate services and utilities including sanitary sewers, and improvements shall be available or provided, located and constructed with sufficient capacity and durability to properly serve the development.
- (h) Any use permitted in any zoning district must also comply with all applicable Federal, State, County and Local health and pollution laws and regulations with respect to noise, smoke and particulate matter, vibration, noxious and odorous matter, glare and heat, fire and explosive hazards, gases, electromagnetic radiation and drifting.
- (i) It is an objective of site plan review to improve the quality of existing developments as they are expanded, contracted, redeveloped, or changed in keeping with sound site development standards of the Village.
- (j) All development phases shall be designed in logical sequence to insure that each phase will independently function in a safe, convenient, and efficient manner without being dependent upon improvements of a subsequent phase.

5. **Filing Fees.**

All applications shall be accompanied by a filing fee to cover the cost of processing and reviewing the application. The fee shall be established by resolution of the Village Council. The filing fee shall be paid before the approval process begins. Upon notification of deficient payment of fees, administrative officials charged with enforcement of the Ordinance shall suspend further review of the application and shall deny any new permits.

Any fees shall be used toward the expense of processing and reviewing the application by the Village. Any portion of the fee not needed to pay such expense shall be refunded without interest to the applicant within thirty (30) days of final action on the application. A schedule of the current filing fees is available in the office of the Village Clerk.

6. **Authorized Applicant.**

The full name, address, telephone number, and signature of the applicant shall be provided on the application. The applicant must be the owner of the property or be an authorized agent of the owner

7. **Records**

The Village shall keep accurate records of all decisions on all applications submitted pursuant to this Ordinance.

b. **Minimum Requirements.**

Manufactured home parks shall be subject to all the rules and requirements as established and regulated by Michigan law and the Manufactured Housing Commission Rules and, in addition, shall satisfy the following minimum requirements:

1. **Parcel Size for Overall Park.**

The minimum parcel size for manufactured home parks shall be fifteen (15) acres.

2. **Minimum Site Size.**

Manufactured Home Parks shall be developed with an average site size of five thousand, five-hundred (5,500) square feet. Individual sites may be reduced to as small as four thousand, four-hundred (4,400) square feet, provided that for every square foot of land gained through such reduction, at least an equal amount of land shall be dedicated as open space for the collective use and enjoyment of all Manufactured Home Park residents. This open space shall be in addition to the open space required by this Article.

3. **Setbacks.**

Manufactured homes shall comply with the following minimum distances and setbacks:

- (a) For a home not sited parallel to an internal road, twenty (20) feet from any part of an attached structure of an adjacent home that is used for living purposes. For a home sited parallel to an internal road, fifteen (15) feet from any part of an attached structure of an adjacent home that is used for living purposes if the adjacent home is sited next to the home or the same internal road or any intersecting internal road.

- (b) Ten (10) feet from any on-site parking space of an adjacent home site.
- (c) Ten (10) feet from an attached or detached structure or accessory of an adjacent home that is not used for living purposes.
- (d) Fifty (50) feet from any permanent community-owned structures, such as either of the following:
 - (1) Clubhouses.
 - (2) Maintenance and storage facilities.
- (e) One hundred (100) feet from any baseball, softball, or similar recreational field.
- (f) Ten (10) feet from the edge of an internal road, provided that such road is not dedicated to the public. Manufactured homes and other structures in the MHP District shall be set back at least twenty (20) feet from the right-of-way line of a dedicated public road within the manufactured home park.
- (g) Seven (7) feet from any parking bay off a home site.
- (h) Seven (7) feet from a common sidewalk.
- (i) In order to better assure compatibility with the established rural character of the Village of Leonard, all manufactured homes, accessory buildings and parking shall be set back not less than twenty (20) feet from any manufactured home park boundary line, except that a minimum setback of fifty (50) feet shall be provided from existing and future right-of-way lines of abutting streets and highways.
- (j) Fifty (50) feet from the edge of any railroad right-of-way.

4. **Maximum Height.**

Buildings in the MHP District shall not exceed two (2) stories or twenty-five (25) feet. However, storage sheds shall not exceed one story and the height of the manufactured home they are intended to serve.

5. **Roads.**

Roads shall satisfy the minimum dimensional, design, and construction requirements of the Manufactured Housing Commission Rules.

- (a) The main entrance to the park shall have access to a public thoroughfare or permanent easement, which shall be recorded by the developers. Sole access to the park via an alley is prohibited.

- (b) All roads shall be hard-surfaced and may be constructed with curbs and gutters.
- (c) In order to assure that a Clear Vision Zone, as described below, is provided at all intersections with County roads and to assure that all construction in a public road right-of-way is performed in accordance with adopted County standards, entryway details, including road section specifications, storm water drainage, landscaping and signage shall be subject to the review and approval of the Village Council. Additionally, all public road improvements proposed as part of the manufactured home park design shall be built to the standards of the public authority that will own and maintain the road.
- (d) Entranceway structures, including but not limited to, walls, columns and gates marking the entrance to a manufactured housing park, may be permitted and may be located in a required setback, except as provided in this Section. Such entranceway structures shall be designed to maintain a Clear Vision Zone as described below and to permit unobstructed access by all emergency equipment and shall comply with all codes and ordinances of the Village. The Village Council shall approve sight distance and a driveway permit must be obtained. The structure shall also be approved by the Village Building Official.
- (e) The Clear Vision Zone is an unobstructed triangular area described as follows: the area formed at the intersection of two road right-of-way lines where the two (2) sides of the triangular area are twenty-five (25) feet long measured along abutting public rights-of-way lines, and the base of the triangle is a line connecting the two end points of the triangle's sides: also, the area formed at the intersection of a road right-of-way line and a driveway where the two (2) sides of the triangle are ten (10) feet long measured along the abutting public rights-of-way line and the edge of the driveway, and the base of the triangle is a line connecting the two end points of the triangle's sides.

6. Parking.

Parking spaces for individual manufactured homes, community facilities in the park, visitors and employees shall be provided as follows:

- (a) All manufactured home sites shall be provided with two (2) parking spaces per Manufactured Housing Commission Rules.
- (b) In addition, a minimum of one (1) parking space for every three (3) manufactured home sites shall be provided for visitor parking located convenient to the area served. Visitor parking spaces shall be counted and designated separately from all other parking spaces including those spaces required for employees and any community facility.

- (c) No unlicensed or inoperable vehicle of any type shall be parked in this district at any time except within a covered building.
- (d) If the owner of the manufactured home park shall permit storage of boats, motorcycles, recreation vehicles, and similar equipment in the manufactured home park, common areas for the storage of that equipment shall be provided by the owner within the park. Such storage shall be limited to use only by residents of the manufactured home park. If proposed, the location of such storage areas shall be shown on the preliminary site plan. No part of any such storage area shall be located in a required setback on the perimeter of the manufactured home park. Such storage area shall be screened from view from existing residences adjacent to the manufactured home park in accordance with the landscaping and screening provisions described in this Article. Park owners who prohibit storage of boats, off-the-road motorcycles, recreation vehicles, and similar equipment are not required to construct common areas for storage.

7. Sidewalks.

Consistent with the overall design and development of residential areas in the Village, concrete sidewalks with a minimum width of three (3) feet shall be provided along one side of collector streets in the manufactured home park. In addition, a five (5) foot wide concrete sidewalk shall be constructed along the public road(s) on which the manufactured home park fronts, such sidewalk shall be located within the road right-of-way or easement, beginning one (1) foot inside the right-of-way or easement line.

8. Accessory Buildings and Facilities.

Any accessory buildings and facilities constructed within the park shall be designed and serviced consistent with the following requirements:

- (a) Accessory buildings and structures, including park management offices and public works facilities, storage buildings, laundry facilities, recreation or community facilities, and other accessory facilities, shall be designed and operated for use by only residents and employees of the park.
- (b) Site-built buildings within a manufactured home park shall be constructed in compliance with the Village Building Code and shall require all applicable Permits, any addition to manufactured home unit that does not comply with the standards of the U.S. Department of Housing and Urban Development for manufactured homes shall comply with the Village Building Codes. Site plan approval shall be required prior to construction of any on-site building within a manufactured home park, except for storage sheds or garages for individual manufactured homes. Storage sheds and garages shall require a building permit from the Building Official prior to construction.

- (c) The installation of any such shed, carport, or garage shall comply with codes and ordinances of the Village of Leonard and shall require a building permit. Storage underneath a manufactured home or unscreened outdoor storage on any manufactured home site is prohibited. The owner of the manufactured home development need not supply storage sheds.

9. **Open Space.**

Open space shall be provided in any manufactured home park containing fifty (50) or more Manufactured Home Sites. The open space shall comply with the following requirements:

- (a) A minimum of two percent (2%) of the park's gross acreage shall be dedicated to usable open space, provided that a minimum of twenty-five thousand (25,000) square feet of open space shall be provided.
- (b) Open space shall be located conveniently in relation to the majority of dwelling units intended to be served. Up to twenty-five percent (25%) of the required open space may consist of wetlands and similar limited use areas, subject to regulation by the Michigan Department of Environmental Quality.

10. **Landscaping and Screening.**

A landscape and screening plan shall be incorporated in the preliminary plans submitted for Site Plan review to the Village Planning Commission. The plan shall indicate the type and size of landscape planting and screening improvements to be completed in the proposed Manufactured Home Park. The landscape and screening plan shall be drawn to the same scale used for preparation of the Site Plan.

- (a) **Perimeter Screening.** All manufactured home parks shall be screened from existing adjacent residences by either a six (6) foot screen wall or a densely planted landscaped screen.
 - (1) **Screen Wall Option.** If provided, screen walls shall be constructed of masonry material that is constructed of face brick, decorative block, or poured concrete with a simulated brick or stone pattern. Required walls shall be placed inside and adjacent to the lot line except where underground utilities would interfere with the placement of the wall.
 - (2) **Landscape Screen Option.** If a landscaped greenbelt is used, it shall consist of closely-spaced evergreen plantings not more than ten (10) feet apart that can be reasonably expected to form a complete visual barrier, at least six (6) feet above ground level at maturity. Deciduous plant materials may supplement the

evergreen materials provided that visual screening, consistent with these requirements, shall be maintained throughout the year.

(b) Landscaping Adjacent to Road.

A landscaped berm measuring at least two and one-half (2 ½) in height shall be constructed along the public roads on which the manufactured home park fronts. The berm shall be constructed with slopes no steeper than one (1) foot vertical rise for each four (4) feet horizontal run. Landscaping adjacent to the road shall comply with the following requirements, consistent with landscaping required for other types of development in the Village of Leonard.

Type	Requirements
Deciduous street tree or Evergreen (such as, Red or Norway Maple, Linden, Ash, Spruce, Austrian Pine)	One (1) per forty (40) lineal feet of road frontage
Deciduous or evergreen shrubs	One (1) per six (6) lineal feet of road frontage

(c) Site Landscaping.

A minimum of one (1) deciduous or evergreen tree shall be planted per two (2) manufactured home sites.

(d) Parking Lot Landscaping.

Off-street parking lots containing more than fifteen (15) spaces shall be provided with at least ten (10) square feet of interior parking lot landscaping per space. Such areas shall measure at least one hundred-fifty (150) square feet and shall be covered by grass, ground cover, shrubs, or other live plant material. At least one (1) deciduous tree shall be planted per parking lot landscaped area.

11. Signs.

Signs shall be permitted in accordance with the following regulations and other safety provisions of this Ordinance. However, in order to avoid visual obstructions, signs above a height of thirty (30) inches from the established street grades shall not be permitted within the triangular area formed by the intersection of any street right-of-way lines and a diagonal line connecting at points twenty-five (25) feet from the intersection of the street right-of-way lines.

- (a) Permitted uses and structures, and permitted uses after special approval as enumerated in this Article shall be permitted:
 - (1) Two (2) signs, each of which shall not exceed five (5) feet in height and sixteen (16) square feet in area and shall be set back a minimum of ten (10) feet from any property or right-of-way line, or,
 - (2) One (1) sign which shall not exceed five (5) feet in height and thirty-two (32) square feet in area and shall be set back a minimum of ten (10) feet from any property or right-of-way line
- (b) Management offices and community buildings in a manufactured home park or a multiple family development shall be permitted one (1) identification sign not to exceed six (6) square feet in area.

12. Trash Dumpsters.

If proposed, trash dumpsters shall comply with the following requirements:

- (a) Dumpsters shall be set back a minimum distance of fifty (50) feet from the perimeter of the manufactured home park and at least fifteen (15) feet from any habitable building, in a location that is clearly accessible to the servicing vehicle.
- (b) Dumpsters shall be screened on three sides with a decorative masonry wall or wood fencing, not less than six (6) feet in height. The fourth side of the dumpster screening shall be equipped with an opaque lockable gate that is the same height as the enclosure around the other three sides.
- (c) Dumpsters shall be placed on a concrete pad, which shall extend six (6) feet in front of the dumpster enclosure. Bollards (concrete filled metal posts) shall be installed at the opening of the dumpster enclosure to prevent damage to the screening wall or fence.

13. Canopies and Awnings.

Canopies and awnings may be attached to any manufactured homes and may be enclosed for use as a sunroom or recreation room, but not as living space. Canopies and awnings shall comply with the setback and distance requirements set forth in this Article and shall require a building permit.

14. Water and Sanitary Sewer Service.

All manufactured home parks shall be served by approved central water and sewage systems, which shall meet the requirements of the Michigan Department of Environmental Quality. The plumbing connections to each manufactured

home site shall be constructed so that all lines are protected from freezing, accidental bumping, or from creating any nuisance or health hazard.

15. **Storm Drainage.**

All storm water drainage improvements shall be subject to the review and approval by the Michigan Department of Environmental Quality (MDEQ) in accordance with the MDEQ Manufactured Home Park Standards.

16. **Telephone and Electric Service.**

All electric, telephone, cable TV, and other lines within the park shall be underground.

17. **Fuel Oil and Gas.**

Any fuel oil and gas storage shall be located in underground tanks, at a safe distance from all manufactured home sites. All fuel lines leading to manufactured home sites shall be underground and designed in conformance with the Manufactured Housing Commission Rules and other applicable local, county, and state regulations.

18. **Operational Requirements.**

(a) **Permit.**

It shall be unlawful for any person to operate a manufactured home park unless that individual obtains a license for such operation. The Village President shall communicate the Village's recommendations regarding the issuance of such licenses to the Director of the Corporation and Land Development Division, of the Michigan Department of Consumer and Industry Services. Additionally, no manufactured home unit shall be placed on a lot in an approved manufactured home park until a building permit has been obtained to approve the manufactured home setup on the lot.

(b) **Violations.**

Whenever, upon inspection of any manufactured home park, the Building Official finds that conditions or practices exist which violate provisions of this Ordinance or other regulations referenced herein, the Building Official shall give notice in writing by certified mail to the Director of Michigan Manufactured Housing Commission, including the specific nature of the alleged violations and a description of possible remedial action necessary to effect compliance with the Ordinance or other regulations. The notification shall include such other information as is appropriate in order to fully describe the violations and potential hazards to the public health, safety, and welfare resulting from the violation. A copy of such

notification shall be sent by certified mail to the last known address of the park owner or agent.

(c) **Inspections.**

The Village Building Official has the authority, to enter upon the premises of any manufactured home park for the purpose of determining compliance with the provisions of this Ordinance or other regulations referenced herein. No manufactured home dwelling shall be occupied until a certificate of occupancy for that dwelling is obtained from the Village Building Department.

(d) **License.**

A Manufactured Home Park shall not be operated until a license has been issued by the Corporation and Land Development Division, of the Michigan Department of Consumer and Industry Services. Buildings constructed on-site, such as a management office or clubhouse shall require a Building Permit prior to construction and a Certificate of Occupancy prior to use.

19. **Sale of Manufactured Homes.**

New or used manufactured homes in manufactured home developments, which are to remain on-site, may be sold by the resident, development owner, licensed retailer, or broker, provided that the manufactured housing development management permits the sale.

20. **School Bus Stops.**

School bus stops shall be located in an area that is acceptable to the school district and the manufactured home park developer.

21. **Mailbox Clusters.**

The United States Postal Service may require that manufactured home parks be served by clusters of mailboxes serving several sites rather than individual mailboxes serving individual sites. If mailbox clusters are required, they shall be located at least two hundred (200) feet from any intersection of a manufactured home park road with a public road.

ARTICLE XII

AG - AGRICULTURAL DISTRICT

Section 12.01 – Statement of Purpose

The AG - Agricultural District is established to permit agricultural uses, related community facilities, and other rural types of development that do not require expensive public services.

Section 12.02 – Principal Permitted Uses

In the Agricultural District, the following uses shall be permitted:

- a. All principal uses and structures permitted in the R-1 and R-2 Single Family Residential Districts, as specified in this Ordinance.
- b. Farm buildings and greenhouses. Main farm barn buildings shall conform to minimum setbacks for principal residential buildings.
- c. Generally recognized farming including livestock and poultry raising, dairying, horticulture, farm forestry and similar bona fide agricultural enterprises or use of land and structures, except that no farm operated wholly or in part for the disposal of garbage, sewage, rubbish, offal or wastes from rendering plants or slaughterhouses shall be permitted. All manure piles or accumulation of refuse shall be located no closer than one-hundred (100) feet to any property line, and a minimum of one hundred and fifty (150) feet from all public rights-of-way.
- d. Truck gardening and nurseries.
- e. Seasonal roadside stands for the display and sale of produce raised on the same premises, which shall be located not less than twenty-five (25) feet from the street or highway right-of-way line and further provided that an open space for three (3) off-street parking spaces, twenty-five (25) feet off the highway or street right-of-way be provided for patrons of such roadside produce stand. A maximum of one (1) roadside stand shall be permitted on any premise.
- f. Publicly owned and operated parks playfields, and other public recreational facilities.
- g. Accessory buildings and uses customarily incidental to the above Principal Permitted Uses.
- h. Off-street parking accessory to the above Principal Permitted Uses in accordance with the requirements of Article VI - Off Street Parking and Loading Requirements.
- i. Wind Energy Systems as specified in Article IV - General Provisions.

Section 12.03 – Permitted Uses After Special Approval

The following uses shall be permitted only after special approval is granted by the Village Council in accordance with the procedures, requirements and standards set forth in this Section and in Article XXVI - Special Approval.

- a. Public utility and municipal, county, regional and state service facilities and uses needed to serve the immediate vicinity, including transformer stations, lift stations and switchboards but excluding outside storage yards.
- b. Private parks, country clubs, gun clubs, golf courses, and golf driving ranges. Any structure on the parcel must be located at least two hundred and fifty (250) feet from a lot line of any adjacent residential district. All ingress and egress shall be directly onto a paved public street.
- c. The raising of fur bearing animals subject to the following conditions:
 1. Lot area shall be sufficient in size to provide not less than two hundred (200) feet between any lot line and any structure, cage or pen housing such fur bearing animals.
 2. All outdoor animal areas shall be screened from view from off site with a sound-deadening masonry wall, at least six (6) feet in height, or a greenbelt of evergreen trees. Such evergreens shall be a minimum of six (6) feet in height at time of planting, and shall be planted and maintained so as to form an opaque screen.
 3. The level of noise emitted from the property shall not exceed sixty (60) decibels, as measured at the property lines.
 4. Facilities shall be established and maintained in accordance with all applicable County and Village sanitation regulations.
- d. Kennels subject to the following conditions:
 1. All kennels shall be located on a lot large enough so that no pens, cages, runs or other kennel structures are closer than two hundred (200) feet from any property line
 2. Dogs shall be kept within an enclosed building during the normal sleeping hours of 10:00 pm through 7:00 am. Such enclosed building shall be constructed with sound-deadening walls and ceiling.
 3. During the hours of 7:00 am until 10:00 pm, dogs shall be permitted in covered outdoor runs or pens. Dog shall be kept confined and not allowed to run at large on the property, except as part of supervised field training.
 4. All outdoor animal areas shall be screened from view from off-site with a sound-deadening masonry wall, at least six (6) feet in height, or a landscaped greenbelt

or evergreen trees. Such evergreens shall be a minimum of six (6) feet in height at time of planting, and shall be planted and maintained so as to form an opaque screen.

5. The level of noise emitted from the property shall not exceed sixty (60) decibels, as measured at the property lines.
 6. When dogs are kept for commercial purposes such as sale, breeding, boarding or training, off-street parking shall be provided at a minimum of one (1) parking space per four (4) dogs that can be accommodated in the kennel.
 7. Kennel facilities shall be established and maintained in accordance with all applicable County and Village sanitation regulations. Kennels shall be constructed with a drained concrete or an approved septic system, or other provision for the safe, sanitary collection and disposal of wastes.
 8. The Planning Commission may specifically limit the number of adult dogs housed in a kennel. Any expansion in the adult dog population of twenty-five (25%) percent or more shall require approval of the Planning Commission.
- e. Cemeteries, subject to the following conditions:
1. Unless established prior to the enactment of this Ordinance, the cemetery site shall contain an area of at least twenty (20) acres.
 2. The site shall be so located as to have at least one (1) property line abutting a major thoroughfare. All ingress and egress to the site shall be directly onto said major thoroughfare.
 3. The perimeter of the site shall be fenced in accordance with Article IV - General Provisions.
 4. Any structure located on the site shall be at least one hundred (100) feet from any lot line.
 5. Compliance with applicable state laws regulating the use of cemeteries.
- f. Airports, landing fields and platforms, hangers, masts and other facilities for the operation of aircraft, subject to the following conditions:
1. The plans for such facilities shall be approved by the Federal Aviation Agency (FAA) and Michigan Department of Aeronautics prior to submittal to the Village for review and approval.
 2. The standards established by the FAA and the Michigan Department of Aeronautics concerning obstruction to air navigation shall be complied with.

3. All required “clear zones” (as defined by the FAA) shall be owned by the airport facility.
 4. Sufficient parking shall be provided for aircraft storage. Additional vehicular parking shall be provided for airport users, and for offices, restaurants, sales rooms, and other uses associated with the airport, subject to the requirements of this Ordinance.
 5. Airports shall be designed so that offices, restaurants, sales rooms, and similar uses are located closest to the road.
- g. Places of Worship subject to the following:
1. Unless established prior to the enactment of this Ordinance, a Place of Worship site shall contain an area of at least two (2) acres.
 2. The site shall be so located as to have at least one (1) property line abutting a major thoroughfare. All ingress and egress to the site shall be directly onto said major thoroughfare.
 3. Wherever the off-street parking area is adjacent to land zoned for residential purposes, a continuous and obscuring wall not less than five (5) feet in height or a landscape buffer strip shall be provided along the side of the parking area adjacent to the residentially zoned land in accordance with Article IV – General Provisions.
 4. In order to mitigate any negative off-site impacts (such as glare, noise, trespassing, fumes, odors or sound) on single-family residential uses the Village may require adequate fencing, screening or landscaping of all or parts of the site.
 5. Related uses, such as social centers, social service centers, schools, nursery school, and rental banquet facilities, among others shall be prohibited unless the Village shall find that adverse impacts will be mitigated.
- h. Nursery schools, day nurseries and child care centers (not including dormitories) provided that for each child so cared for, there shall be provided and maintained a minimum of seven hundred (700) square feet of outdoor play area. Such play space shall be screened from any adjoining lot in any residential district in accordance with Article IV - General Provisions. All vehicular access shall be only from a paved public street.
- i. Travel trailer parks and campgrounds, subject to the requirements as established and regulated by Act 243 of the Public Acts of 1959, as amended, except that the same shall conform to the following requirements:
1. Minimum lot size shall be five (5) acres. The lot shall provide direct vehicular access to a public street or road. The term “lot” shall mean the entire campground or travel trailer park. Each lot shall be provided with at least one (1) public telephone.

2. Each site on a lot designated for camping use may accommodate a travel trailer or tent, and shall be provided with individual electrical outlets and with individual outdoor cooking facilities.
 3. Each site shall contain a minimum of fifteen hundred (1,500) square feet, except that the minimum size for sites specifically designated for tents shall be three thousand (3,000) square feet. Each site shall be set back from any right-of-way or property line at least seventy-five (75) feet.
 4. A common use area shall be provided on each lot at a ratio of not less than one thousand (1,000) square feet of such area per each site. This common area shall be developed by seeding, landscaping, picnic tables, barbecue stands and passive recreation equipment (i.e., swings, horseshoe pits, shuffleboard courts and the like) for the general use of all occupants of the entire lot.
 5. Each travel trailer site shall have direct access to a hard-surfaced, dust free roadway of at least twenty-four (24) feet in width for two-way traffic and twelve (12) feet in width for one-way traffic. Parking shall not be allowed on any roadway. Public streets shall be paved with asphaltic concrete. Sites specifically designated for, and only used for, tent camping, need not have direct vehicular access to any street or road, but shall be provided with adequately cleared and marked pedestrian pathway access from parking areas. All sanitary facilities shall be designed and constructed in strict conformance to all applicable State and County health regulations.
 6. A minimum distance of fifteen (15) feet shall be provided between all travel trailers and tents.
 7. The Planning Commission may require fences and greenbelts. The location of common use areas, roadways, streets, and buildings shall be subject to approval by the Planning Commission.
- j. Temporary uses and buildings, including temporary buildings or structures for use incidental to construction work.
 - k. Public and private stables and riding academies provided that any building used as a stable shall not be located nearer than sixty (60) feet to any property line and not nearer than one hundred (100) feet to any dwelling unit.
 - l. Accessory uses, buildings, structures, customarily incidental to any of the above permitted uses.
 - m. Uses similar to the above uses, based on specific determination by the Planning Commission.
 - n. Telecommunication towers, antennas and related structures, subject to the requirements of Article XXI - Wireless Telecommunications Towers and Antennas and:

1. Only areas planned for future agricultural use according to the Village Future Land Use Plan shall be eligible for placement of telecommunication towers, antennas and related structures.

Section 12.04 – Area, Height, Bulk and Placement Requirements.

Area, height, Bulk and Placement Requirements unless otherwise specified are as provided in Article XVIII - Schedule of Regulations.

Section 12.05 – Site Plan Review

In accordance with Article XXV- Site Plan Review, with the exception of permitted principal agricultural uses and single family detached residential uses, a Site Plan shall be required for all principal and Special Approval Uses permitted in this District.

Section 12.06 – Environmental Impact Environmental Impact Assessment

- a. An environmental impact assessment, in accordance with Article XXV - Site Plan Review, may be required by the Planning Commission or the Village Council.
- b. All required environmental impact assessments shall be furnished by the applicant at the applicants' sole expense.

ARTICLE XIII

R - 1F SMALL FARM DISTRICT

Section 13.01 – Statement of Purpose

The R-IF - Small Farm District is established as a very low-density district, in which the principal use of the land is for single-family dwellings while allowing for the continuation of limited agricultural uses. This Zoning District is intended to provide a living environment that helps preserve the semi-rural character of the Village's periphery, particularly in areas with sensitive environmental features.

Section 13.02 – Permitted Principal Uses.

In the R-IF district, the following uses shall be permitted:

- a. Single family detached dwellings.
- b. Family Child Care Homes subject to the standards of this Ordinance and the regulations in Section 206 of the Michigan Public Act 110 of the Public Act of 2006, MCL 125.3206, as amended.
- c. State Licensed Residential Facilities that provide resident services for six (6) or fewer persons under 24-hour supervision or care, including Foster Care Facilities, subject to the standards of this Ordinance and the regulations in Section 206 of the Michigan Public Act 110 of the Public Act of 2006, MCL 125.3206, as amended.
- d. Publicly-owned and operated parks, playfields, swimming pools, playgrounds, and other public recreational facilities, not including outside storage areas.
- e. The raising and keeping of fowl and/or rabbits for private use and consumption, in accordance with the requirements of Article IV - General Provisions of this Ordinance.
- f. Hobby farms and private stables provided that they meet the following:
 1. Any horses kept shall be for recreational purposes for the private personal use of the owner or lessee of such land, his family, and friends
 2. Any commercial sales of crops or livestock shall be limited to goods raised on the hobby farm.
 3. Compliance with the requirements of Article IV – General Provisions of this Ordinance.
- g. Greenhouses and nurseries provided that there are no commercial sales on the premises.
- h. Accessory buildings and uses customarily incidental to the above Principal Permitted Uses.

- i. Off-street parking accessory to the above Principal Permitted Uses in accordance with the requirements of Article VI - Off Street Parking and Loading Requirements.

Section 13.03 – Permitted Uses after Special Approval

The following uses shall be permitted subject to the conditions hereinafter imposed and subject further to the approval of the Village Council, in accordance with the procedures, requirements and standards set forth in this Section and in Article XXVI - Special Approval.

- a. Places of Worship subject to the following conditions:
 - 1. Unless established prior to the enactment of this Ordinance, a Place of Worship site shall contain an area of at least two (2) acres.
 - 2. The site shall be so located as to have at least one (1) property line abutting a major thoroughfare. All ingress and egress to the site shall be directly onto said major thoroughfare.
 - 3. Wherever the off-street parking area is adjacent to land zoned for residential purposes, a continuous and obscuring wall not less than five (5) feet in height or a landscape buffer strip shall be provided along the sides of the parking area adjacent to the residentially zoned land in accordance with Article IV - General Provisions.
- b. Cemeteries, subject to the following conditions:
 - 1. Unless established prior to the enactment of this Ordinance, the cemetery site shall contain an area of at least twenty (20) acres.
 - 2. The site shall be so located as to have at least one (1) property line abutting a major thoroughfare. All ingress and egress to the site shall be directly onto said major thoroughfare.
 - 3. The perimeter of the site shall be fenced in accordance with Article IV – General Provisions.
 - 4. Any structure located on the site shall be at least one hundred (100) feet from any lot line.
 - 5. Compliance with applicable state laws regulating the use of cemeteries.
- c. Public utility buildings, telephone exchange buildings, electric transformer stations and substations, and gas regulator stations, subject to the following conditions:
 - 1. Such uses shall be permitted only when location in residential areas is required to serve the immediate vicinity.
 - 2. No outside service or storage yards shall be permitted.

3. All structures shall be at a scale and have an exterior appearance compatible with a residential area.
 4. All lines serving such sites shall be underground. Overhead transmission lines and tower structures are expressly prohibited.
- d. Municipal, state or federal uses, public libraries, public museums and community centers, provided that no outside services or storage yards shall be permitted.
- e. Public, parochial and other private elementary or secondary schools offering courses in general education and not operated for profit, subject to the following conditions:
1. No building shall be closer than fifty (50) feet to any property line when said property line abuts or is adjacent to land zoned or used for residential purposes.
 2. All vehicular access shall be only from a paved public street.
 3. All buses shall be stored off-site.
 4. All parking and circulation shall be paved in accordance with the off-street parking standards of this Ordinance.
- f. Nursery schools, day nurseries and child care centers (not including dormitories) provided that for each child so cared for, there shall be provided and maintained a minimum of seven hundred (700) square feet of outdoor play area. Such play space shall be screened from any adjoining lot in any residential district in accordance with Article IV – General Provisions. All vehicular access shall be only from a paved public street.
- g. Private parks, country clubs, golf courses, and golf driving ranges. Any structure on the parcel must be located at least two hundred and fifty (250) feet from a lot line of any adjacent residential district. All ingress and egress shall be directly onto a paved public street.
- h. Group Child Care Homes subject to the standards of this Ordinance and the regulations in Section 206 of the Michigan Public Act 110 of the Public Act of 2006, MCL 125.3206, as amended.
1. The group child care home is not located closer than one-thousand and five-hundred (1,500) feet to any of the following:
 - (a) Another licensed group child care home.
 - (b) Another licensed adult-foster care small group home or large group home.
 2. Appropriate fencing for the safety of the children in the group child care home is provided in accordance with the requirements of Article IV – General Provisions.

3. The lot location shall be such that at least one (1) property line abuts a major thoroughfare. The ingress and egress for off-street parking areas of residents, employees, and guests shall be directly from said thoroughfare.
4. The group child care home facility shall not be injurious to the use and enjoyment of other property in the immediate vicinity for the purposes permitted, nor substantially diminish or impair property values within the neighborhood.
5. The principal and accessory buildings shall be a minimum of one hundred (100) feet from any residential structure in the district.
6. The group child care home facility shall meet all applicable requirements of the Michigan Department of Human Services.

Section 13.04 – Area, Height, Bulk and Placement Requirements

Area, height, bulk, and placement requirements, unless otherwise specified, are as provided in Article XVIII - Schedule of Regulations.

Section 13.05 – Site Plan Review

In accordance with Article XXV - Site Plan Review, with the exception of permitted principal agricultural uses and single family detached residential uses, a site plan shall be required for all principal and Special Approval Uses permitted in this District.

Section 13.06 – Environmental Impact Assessment

- a. An environmental impact assessment, in accordance with Article XXV - Site Plan Review, may be required by the Planning Commission or the Village Council.
- b. All required environmental impact assessments shall be furnished by the applicant at the applicants' sole expense.

ARTICLE XIV

C-1 - VILLAGE COMMERCIAL DISTRICT

Section 14.01 – Statement of Purpose

The C-1 - Village Commercial District is primarily intended to permit retail business and service uses which provide for the convenient shopping needs of Village residents. Furthermore, the intent is to encourage mixed uses with a Village scale and character. Uses permitted in this district are intended to be compatible with residential structures and surrounding neighborhoods, and are intended to be oriented to pedestrians. In order to promote such development, so far as is possible and appropriate, uses are prohibited which would create hazards, offensive and loud noises, offensive and/or obscene printed language visible from street and/or residential properties, vibration, smoke, glare, heavy truck traffic, or late hours of operation. The intent of this Zoning District is also to encourage the concentration of local businesses to the mutual advantage of both the consumers and merchants and thereby promote the best use of land at certain strategic locations and discourage marginal strip business development along major streets.

It is further the intent of this Zoning District to encourage the retention of existing residential structures, either in residential use or converted to other permitted uses, and to ensure that remodeled or new structures will have a character similar to the existing small town character of the Village.

Section 14.02 – Permitted Principal Uses

In the Village Commercial District, the following uses shall be permitted:

- a. Retail food establishments, which supply: groceries, fresh produce, meats, dairy products, baked goods, confections, or similar commodities for consumption off the premises. Food stuffs may be prepared on the premises as an accessory use if sold at retail prices on premise.
- b. Restaurants, delicatessens and other establishments serving food and/or beverages on the premises, which may include seasonal outdoor seating, but without drive-through or drive-in services.
- c. Banks, savings and loan, credit unions and other financial institutions without drive-through facilities.
- d. Stand-alone automatic teller banking machines.
- e. Retail businesses conducted entirely within an enclosed building such as: drug stores, liquor sales, dry good, clothing, furniture, hardware, music, book stores, antique stores, and gift shops.

- f. Personal service establishments such as but not limited to: small electronics repair shops, shoe repair, tailors, hair styling salons, photographers studios, art studios, film processing outlets, copy centers, interior decorators, postal centers and dry cleaners.
- g. Professional offices such as medical, dental, chiropractors, osteopaths, insurance, real estate, attorney, financial and similar or allied professionals.
- h. Places of Worship.
 - 1. Unless established prior to the enactment of this Ordinance, a Place of Worship site shall contain an area of at least two (2) acres.
 - 2. The site shall be so located as to have at least one (1) property line abutting a major thoroughfare. All ingress and egress to the site shall be directly onto said major thoroughfare.
 - 3. Wherever the off-street parking area is adjacent to land zoned for residential purposes, a continuous and obscuring wall not less than five (5) feet in height or a landscape buffer strip shall be provided along the side of the parking area adjacent to the residentially zoned land in accordance with Article IV – General Provisions.
- i. Public parks and municipal buildings such as a library, community center, fire station, Village offices and museums.
- j. Post offices.
- k. Newspaper offices.
- l. Accessory uses, buildings, structures customarily incidental to any of the above Permitted Uses.
- m. Uses similar to the above and subject to the following restrictions:
 - 1. All business establishments shall be retail or service establishments dealing directly with consumers. All goods produced on the premises shall be sold at retail on the premises where produced.
 - 2. All business, servicing or processing, except off-street parking or loading, shall be conducted within a completely enclosed building.

Section 14.03 – Permitted Uses after Special Approval

The following uses shall be permitted only after Special Approval is granted by the Village Council in accordance with the procedures, requirements and standards set forth in this Section and in Article XXVI - Special Approval Procedures and Standards, and subject to any conditions imposed by the Village Council:

- a. Automobile service stations for sale of gasoline, oil, and automobile repair, subject to the requirements of Article IV - General Provisions.
- b. Fast-food, drive-in, and drive-through restaurants, subject to the following conditions:
 - 1. All buildings shall be set back a minimum of sixty (60) feet from any adjacent right-of-way line or residential property line.
 - 2. Drive-through windows or other facilities and waiting lanes shall not be located within one hundred (100) feet of a residential zoned district.
 - 3. Ingress and egress to the site shall be located at least sixty (60) feet from the intersection of any two (2) streets (measured from the nearest right-of-way line).
 - 4. Devices for the transmission of voices shall not be audible beyond the boundaries of the site.
 - 5. In the case any off-street parking area abuts a lot in any residential district, a five (5) foot high wall or greenbelt shall be provided, in accordance with Article IV - General Provisions.
 - 6. Construction to be of a style compatible with Village character.
- c. Bars, taverns, and lounges.
- d. Public utility and municipal, county, regional, and state service facilities and uses needed to serve the immediate vicinity, including transformer stations, lift stations and switchboards, but excluding outside storage yards.
- e. Bed and breakfast establishments, tourist homes subject to the following requirements:
 - 1. The owners or operators shall be permanent residents of all such inns which shall remain as single family homes in appearance and shall have no internal or external structural alterations. An example would be no enlargement of the kitchen for volume food service.
 - 2. Off-street parking shall be provided for the households and guests as follows: two (2) parking spaces plus one (1) additional space per room to be rented.
 - 3. There shall be ample open space other than that required to accommodate the required off-street parking. Natural screening by use of plant material or other screening may be required to screen parking areas from adjoining residential properties. Off-street parking in front yard areas shall not be permitted.
 - 4. Food may be served in an inn to those persons renting an inn room only during their stay in at the inn.

5. They shall not have or be converted to more rental rooms than the number of bedrooms which exist at the time of enactment of this Ordinance and the maximum number of rooms that they may rent at one time shall not exceed five (5).
 6. The lot location shall be such that at least one (1) property line abuts a paved public street. All ingress and egress to the lot shall be directly onto said street.
- f. Banks, savings and loans and similar financial institutions with up to two (2) drive through stations.
 - g. Commercial schools and dance studios.
 - h. Funeral homes.
 - i. Medical clinics, nursing and convalescent homes.
 - j. Video/DVD rental establishments.
 - k. Fitness centers, health spas and commercial indoor recreation establishments such as bowling alleys, pool halls, and racquetball courts.
 - l. Clubs, indoor theaters, and lodge halls.
 - m. Commercial parking lots, parking structures and community garages.
 - n. Single-family and multi-family uses shall be permitted in an existing structure, subject to the following:
 1. In buildings used for mixed business and residential occupancy, no dwelling unit shall occupy any portion of the floor at grade level. The business uses may occupy any number of total floors; however, no business may be located on the same floor as a residential use, and no floor may be utilized for business purposes which is located above a floor used for residential purposes.
 2. Each dwelling unit shall have a minimum floor area as provided in Article XVIII - Schedule of Regulations, for Multiple-Family Dwellings.
 3. Off-street parking shall be provided as required in this Ordinance.
 - o. Wholesale stores and warehousing, subject to the following:
 1. At least thirty (30%) percent of the ground floor area of the building shall be occupied by retail or service operations.
 2. All loading and unloading, truck parking and maneuvering shall be contained entirely on the subject property.
 - p. Adult Regulated Uses in accordance with Article IV – General Provisions.

- q. Accessory uses, buildings, structures customarily incidental to any of the above Permitted Uses.
- r. Uses similar to the above uses, based on specific determination by the Planning Commission.

Section 14.04 – Required Conditions for Village Commercial Uses

Except as otherwise noted for specific uses, buildings and uses in the Village Commercial District shall comply with the following required conditions:

- a. All business establishments shall be retail or service establishments dealing directly with the customers except as expressly provided above. All goods produced and services performed on the premises shall be sold at retail on the premises where produced.
- b. All business, servicing, or processing, except off-street parking and loading, shall be conducted within a completely enclosed building, unless otherwise specifically permitted.
- c. Exterior walls facing public rights-of-way, customer parking areas, and adjoining property that is zoned or used for residential purposes shall have a finished appearance, using the same materials as used on the front of the building. Wherever possible, meter boxes, dumpsters, and mechanical equipment should not be located on a side of the building that faces residentially-zoned or used property.
- d. There shall be no outside storage of any goods, inventory, or equipment.
- e. All buildings in the Zoning District, when remodeled, expanded, or constructed, shall be compatible with the existing Village scale and small town, predominately residential character. The following criteria shall be considered by the Planning Commission in making findings regarding the acceptability of the exterior design of a proposed building and as requirements for Site Plan Approval. These criteria shall be evaluated in terms of the purpose of this Zoning District, other criteria set forth in this Section, and other buildings in the district.
 - 1. Building height.
 - 2. Proportions of the building's front façade; relationship of width to height.
 - 3. Proportion of openings in the front façade; the relation of width to height of windows and doors.
 - 4. Placement of the building relative to rhythm of building spacing along the street.
 - 5. Rhythm of entrance and front porch projections.
 - 6. Use of traditional exterior materials, textures, colors and architectural details, (i.e., wood, brick, stone, clapboard siding, etc.).

7. Relationship of roof shapes.
8. Building scale in relation to surroundings.
9. Appropriateness of landscaping.

Section 14.05 – Area, Height, Bulk, and Placement Requirements.

Area, height, bulk, and placements requirements, unless otherwise specified, are as provided in Article XVIII - Schedule of Regulations.

Section 14.06 – Site Plan Review

In accordance with Article XXV - Site Plan Review, with the exception of permitted principal agricultural uses and single family detached residential uses, a Site Plan shall be required for all principal and Special Approval Uses permitted in this district.

Section 14.07 – Environmental Impact Assessment

- a. An environmental impact assessment, in accordance with Article XXV - Site Plan Review, may be required by the Planning Commission or the Village Council.
- b. All required environmental impact assessments shall be furnished by the applicant at the applicants' sole expense.

ARTICLE XV

LI - LIMITED INDUSTRIAL DISTRICT

Section 15.01 – Statement of Purpose

The LI - Limited Industrial District is designed so as to primarily accommodate Wholesale Activities, Warehousing, and Light Industrial Operations whose external, physical effects are restricted to the area of the district and in no manner affect in a detrimental way any of the surroundings districts. The LI District is so structured as to permit, along with any specified uses, the manufacturing, compounding, processing, packaging, assembly, and/or treatment of finished or semi-finished products from previously prepared material.

Section 15.02 – Permitted Principal Uses

In the Limited Industrial District, the following uses shall be permitted:

- a. Any use charged with the principal function of basic research, design, and pilot or experimental project development when conducted within a completely enclosed building. The growing of any vegetation requisite to the conducting of basic research shall be excluded from the requirement of enclosure.
- b. Any of the following uses:
 1. Warehousing and wholesale establishments.
 2. The manufacture, compounding, processing, packaging, or treatment of such products as, but not limited to: bakery goods, candy, cosmetics, pharmaceuticals, toiletries, food products, hardware and cutlery, tool, die, gauge and machining shops.
 3. The manufacturing, compounding, assembling, or treatment of articles or merchandise from previously prepared materials such as, but not limited to: bone, canvas, cellophane, cloth, cork, elastomers, feathers, felt, fiber, fur, glass, hair, horn, leather, paper, plastic, rubber, precious or semi-precious metals or stone, sheet metal, shell, textiles, tobacco, wax, wire, wood and yarns.
 4. The manufacture of pottery and figurines or other similar ceramic products using only previously pulverized clay, and kilns fired only by electricity or gas.
 5. Manufacture of musical instruments, toys, novelties, and metal or rubber stamps, or other molded rubber products.
 6. Manufacture or assembly of electrical appliances, electronic instruments and devises, radios phonographs and television.
 7. Laboratories: experimental, film, or testing.

- 8. Manufacturing and repair of electric or neon signs, light sheet metal products, including heating and ventilating equipment, cornices, eaves and the like.
- c. Central dry cleaning plants or laundries provided that such facilities do not deal directly with the customer at retail.
- d. Printing, lithography, blueprinting, and similar uses.
- e. Greenhouses and plant nurseries.
- f. Data processing and computer centers, including electronic data processing and computer equipment service establishments.
- g. Uses which are similar to above uses.
- h. Essential services.
- i. Uses and structures accessory to the above. Accessory office and sales operations may be permitted where such activities are clearly incidental to the principal industrial use.

Section 15.03 – Permitted Uses after Special Approval

The following uses shall be permitted only after special approval is granted by the Village Council in accordance with the procedures, requirements and standards set forth in this Section and in Article IV - General Provisions, and subject to any conditions imposed by the Council.

- a. Automotive repair garages, auto engines and body repair, and undercoating shops when completely enclosed.
- b. Retail uses which have an industrial character in terms of either their outdoor storage requirements or activities (such as, but not limited to: lumber yards, building materials outlets, boat and recreational vehicle sales or service, house trailer sales, automobile sales, or agricultural implement sales).
- c. Railroad classification yard and related facilities, including rail car storage, marshaling, switching and transfer facilities, facilities for maintaining railroad cars, tool and equipment storage buildings, radio communication towers, transmission towers, and crew quarters.
- d. Public utility or municipal service buildings, including electric or gas service buildings and yards, telephone exchange buildings, electric transformer stations, gas-regulator stations, water treatment plants and reservoirs, and sewage treatment plants.
- e. Recycling collection stations and centers.
- f. Oil and gas processing facilities, subject to these provisions:
 - 1. Setbacks

- (a) Oil and gas processing plants shall be located a minimum of one thousand and three-hundred (1,300) feet from any existing residential, commercial, or industrial establishments, wetlands, or surface water.
 - (b) Oil and gas processing plants shall be located a minimum of two thousand, six-hundred and forty (2,640) feet from population concentrations, such as subdivisions, apartment buildings, residential developments, or mobile home parks, and from uses whose occupants would be difficult to evacuate, such as hospitals or nursing homes.
- 2. There shall be no more than one (1) oil and gas processing facility in operation per square mile section of land. Such facilities shall be designed to service all oil and gas wells that are expected to need such service within a two (2) mile radius.
- 3. Oil and gas processing facilities shall be screened, in accordance with Article IV – General Provisions.
- 4. Emissions from the plant shall meet or exceed all applicable State and Federal pollution standards. Monitors/sensors shall be installed in at least four (4) locations along the perimeter of the site. In addition, monitors shall be installed in all process buildings. These monitors shall be set to alarm and automatically cause the plant to be shut down upon detection of excessive concentrations of hydrogen sulfide, sulfur dioxide, methane, or other gases. The plant operator shall provide the Village with the instrument shut down set points, which shall be subject to review and approval. All monitors shall be maintained in proper working order at all times.
- 5. The fire detection and suppression system shall be constructed and maintained in accordance with state and local fire and building codes, and as approved by the Village Fire Chief or other designated Fire Official. Fire eyes shall be installed in storage tank areas and in process buildings.
- 6. Oil and gas processing plants shall comply with the noise standards set forth in Article VII - Performance Standards.
- 7. In the event that instruments, sensors, or monitors detect a malfunction of the system, including but not limited to the detection of gas leaks, odors, fire, flare failure, or improper operation of the processing equipment, an alarm system shall be set to automatically operate.

The alarm system shall be operated through a bonded alarm company approved by the Village Fire Chief or other designated Fire Official. The alarm company shall be instructed to contact the designated Fire Department dispatcher and facility operating personnel.

- 8. The following security measures shall be maintained on the site:
 - (a) **Fencing.**

The site shall be fully enclosed with a gated six (6) foot high chain link fence with three (3) strands of barbed wire along the top of the fence.

(b) **Locking of the Facility**

All building doors and fence gates shall be kept closed and locked, except when personnel are at the site during the daytime hours.

(c) **Signs**

“Poisonous Gas” or other appropriate warning signs shall be placed at fifty (50) foot intervals along the fence surrounding the facility. The warning signs shall have a reflective surface.

(d) **Lighting**

The site shall be adequately lighted.

(e) **Telephone Monitoring System**

In the event of a break-in or other lapse of security, the bonded alarm system shall automatically be put into operation, and operating personnel and local law enforcement officials shall be notified.

9. The facility shall be maintained in proper operating condition at all times. Manufacturer’s recommendations concerning periodic maintenance shall be adhered to.
10. In the event that operation of the facility is terminated for a period exceeding six (6) months, all equipment and surface piping shall be removed and foundations shall be destroyed to a depth of thirty-six (36) inches below grade. The entire site shall be evenly graded and reseeded.
11. The applicant shall submit proof of permits and approvals from all state or county agencies having jurisdiction, including but not limited to: the Michigan Department of Natural Resources (MDNR), Michigan Department of Environmental Quality (MDEQ), Oakland County Health Division, Road Commission for Oakland County, Oakland County Water Resource Commission, and Michigan Department of State Police Fire Marshall Division.

g. Mini-warehouses, subject to the following provisions:

1. Mini-warehouse establishments shall provide for storage only, which must be contained within an enclosed building.
2. The entire site, exclusive of access drives, shall be enclosed with a five (5) foot high masonry wall, constructed in accordance with Article IV - General

Provisions, a six (6) foot chain link fence may be permitted along property lines which do not abut a residentially zoned or used district.

3. The exterior of any mini-warehouse shall be of finished quality and design, compatible with the design of structures on surrounding property.
 4. A resident manager shall be required on the site and shall be responsible for maintaining the operation of the facility in conformance with the conditions of the approval.
- h. Construction equipment and related equipment sales, leasing, and storage, subject to the following conditions:
1. Where feasible, equipment shall be stored inside. Open storage structures may be permitted by the Planning Commission, provided that such structures are enclosed on three (3) sides and have a roof.
 2. Storage yards shall be screened from any abutting public or private road.
- i. Landscaping contractor's operation, subject to the following:
1. There shall be no outside storage or stock piling of materials or debris, other than peat, bark, stone and similar raw materials normally used in the nursery/landscaping business. Such materials shall be screened so they are not visible from any property line.
- j. Metal plating, buffering and polishing.
- k. Junk yards, in addition to other regulations set forth in this Ordinance, shall conform to the following requirements:
1. The junkyard shall be located with frontage on a public street.
 2. Travel routes for trucks entering and leaving the junkyard shall be shown on a map of the Village at the time of application for the Special Approval Use Permit. Such routes except for major thoroughfares or their equivalent shall not pass through residential areas.
 3. A Site Plan shall be provided at the time of the Special Approval Use Permit application and shall meet all requirements of Article XXV - Site Plan Review. The Site Plan shall also contain a description of the location and nature of any materials processing operations to be conducted within the junkyard, and the location and nature of equipment for such operations.
 4. Junk materials shall be stored in organized rows with open intervals at least twenty (20) feet wide between rows for purposes of fire protection access and visitor safety.

5. Junk materials shall not be stored in piles higher than the top of the fence surrounding the junkyard. Automobiles, trucks and other vehicles shall not be stacked so as to prohibit fire protection and to protect the safety of visitors.
6. The junkyard shall be maintained in such a manner as to prevent the breeding or harboring of rats, insects or other vermin.
7. The junkyard, when established and located within one thousand (1,000) feet of any existing residential district, as measured on a straight line distance, shall not be open for business and shall not be operated at any time other than between the hours of 7:00 am and 6:00 pm on weekdays and Saturday; and shall not be open for business or otherwise operate on Sundays or legal Holidays.
8. Burning shall be prohibited except within an enclosed incinerator, and only if the burning operation and incinerator are approved by the Fire Chief or other designated fire official, the Building Official, and the County Health Division.
9. All toxic or hazardous liquids contained in automobiles and other vehicles shall be drained from same immediately after such vehicles are brought to the junkyard. Such liquids are to be stored in containers approved by the Fire Chief or other designated fire official.
10. All drives, parking areas and loading/unloading areas shall be paved, watered, or chemically treated so as to limit nuisances caused by windborne dust or neighboring properties and on public roads.
11. There shall be not more than one (1) entrance way from each public street, which adjoins the junkyard.
12. Fencing shall be required as follows:
 - (a) A solid, opaque fence or wall, seven (7) feet high as measured from grade at each post in the case of a fence, or at ten (10) feet intervals in the case of a wall, shall be provided along each public street frontage. The fence or wall shall be located on the rear line of the required front yard. Gates shall also be made of solid, opaque material. The front yard shall be landscaped and continuously maintained as a lawn.
 - (b) Where the junkyard is adjacent to a rural or urban residence, or commercial district, a solid, screen type fence or wall, seven (7) feet high shall be provided on any side or rear property line or portion thereof, adjoining such lots.
 - (c) The fence or wall shall be continuously maintained in such a manner that breakages, decay, etc., are repaired within thirty (30) days of notice by the Village and routine maintenance, such as painting, etc., shall also be performed within thirty (30) days of notice from the Village.

- (d) Strips of metal, plastic or other material inserted into wire fences shall not be permitted in any fence enclosing a junkyard.
- 13. Wrecking and processing operations are permitted in a junkyard, but shall be described in the application for the Special Use Permit.
 - l. Uses or structures accessory to the above when located on the same lot and not involving any business, profession, trade or corporation.
 - m. Uses similar to the above uses based upon specific determination by the Planning Commission.

Section 15.04 – Required Conditions for Industrial Uses

- a. All manufacturing, compounding, assembling, processing, packaging, or other industrial or business activity shall comply with the Performance Standards set forth in Article VII - Performance Standards of this Ordinance.
- b. All manufacturing, compounding, assembling, processing, packaging, or other industrial or business activity shall be conducted within a completely enclosed building, except as otherwise specified.
- c. All machinery shall comply with the Performance Standards in Article VII - Performance Standards.
- d. All raw materials and supplies shall be stored within a completely enclosed building unless otherwise provided therein. Outside storage of finished or semi-finished products may be permitted, subject to the following conditions:
 - 1. Such storage shall be screened with fencing.
 - 2. No material shall be stored above the height of the screening.
 - 3. Storage areas shall conform to the setback requirements for buildings in the LI District.
 - 4. Access to all parts of the storage areas shall be provided for fire and emergency services.

Section 15.05 – Area, Height, Bulk and Placement Requirements

Area, height, bulk, and placement requirements, unless otherwise specified, are as provided in Article XVIII - Schedule of Regulations.

Section 15.06 – Site Plan Review

In accordance with Article XXV - Site Plan Review, with the exception of permitted principal agricultural uses and single family detached residential uses, a Site Plan shall be required for all principal and special approval uses permitted in this district.

Section 15.07 – Environmental Impact Assessment

- a. An environmental impact assessment, in accordance with Article XXV - Site Plan Review, may be required by the Planning Commission or the Village Council.
- b. All required environmental impact assessments shall be furnished by the applicant at the applicants' sole expense.

ARTICLE XVI

PUD - PLANNED UNIT DEVELOPMENT

Section 16.01 – Statement of Intent

It is the intent of this Article to permit flexibility in the regulation of land development; encourage innovation in land use and variety in design, layout, and type of structures constructed; achieve economy and efficiency in the use of land, natural resources, energy, and public services and utilities; encourage useful open space; and provide better housing; employment, and shopping opportunities particularly suited to the needs of the residents of the Village of Leonard.

The approval of a Planned Unit Development application shall require an Amendment to this Ordinance to revise the Zoning Map and designate the subject property as “PUD, Planned Unit Development - Overlay”. Approval granted under this Article, including all aspects of the final plan and conditions imposed on it, shall constitute an inseparable part of the Zoning Amendment.

The provisions of this Article are not intended as a device for ignoring the Ordinance and specific standards set forth herein, or the planning upon which it has been based. Provisions of this Article are intended to result in land development substantially consistent with the Ordinance standards generally applied to the proposed uses, allowing for modifications and departures from generally applicable standards in accordance with guidelines in this Section.

Section 16.02 – Permitted Principal Uses

In a Planned Unit Development, the permitted principal uses in the AG-Agricultural District, the R-1 and R-2 - Single Family Residential Districts, and the R-1F - Small Farms District and C-1 - Village Commercial District, or any combination of these uses shall be permitted.

Section 16.03 – Regulations

The following regulations shall apply to all Planned Unit Developments:

- a. **Unified Control.** The proposed Planned Unit Development area shall be under the control of one owner or a single entity and shall be capable of being planned and developed as one integral unit. Application for Planned Unit Development zoning must be made with the written authorization of all owners of the site and with all parties having an interest in the property joining in said application.

The applicant shall provide legal documentation of single ownership or control in the form of agreements, contracts, covenants, and deed restrictions which indicate that the development can be completed as shown on the plans, and further, that all portions of the development will continue to be operated and maintained by the developers or their successors. These legal documents shall bind all development successors in title to any commitments made as a part of the documents. This provision shall not prohibit a transfer of ownership or control, provided notice of such transfer is given to the Village.

- b. **Minimum Size.** The minimum size of a Planned Unit Development shall be at least ten (10) acres of contiguous land.
- c. **Street Provisions and Vehicular Access.** The land shall abut a major street as defined in Act 51, P.A. 1951. In addition, each lot, main building, and principal use within the Planned Unit Development shall have vehicular access from a public street or an approved private road meeting the requirements of the Village's Street Ordinance, Ordinance No 28 and this Ordinance. Adequate provision shall be made for dedications of land for streets and essential services.
- d. **Benefit.** A Planned Unit Development shall result in a recognizable and substantial benefit to ultimate users of the PUD, and the community, and shall result in a higher quality of development than could be achieved under conventional zoning.
- e. **Applicable Base Regulations.** Unless waived or modified in accordance with the procedures and standards set forth in this Article, the yard and bulk, parking, loading, landscaping, lighting, and other standards set forth in the districts listed below shall generally be applicable for uses proposed as part of a Planned Development:
 - 1. Single family residential uses shall comply with the regulations applicable in the underlying residential district. If the underlying district is a non-residential district, the Village Council, upon the recommendation of the Planning Commission shall establish the regulations applicable to single family-residential uses.
 - 2. Agricultural uses shall comply with the regulations applicable in the AG-Agricultural District.
 - 3. Multiple-Family Residential uses shall comply with the regulations applicable in the MD - Multiple Family Residential District.
 - 4. Mixed uses shall comply with the regulations applicable for each individual use, as outlined above, except that if conflicts exist between provisions, the regulations applicable to the most dominant use shall apply.

To encourage flexibility and creativity in development consistent with the Planned Unit Development concept, departures from compliance with the underlying Zoning District Regulations may be granted by the Village Council, upon recommendation of the Planning Commission, as part of the approval of the Planned Unit Development. For example, such departures may include modifications of lot dimensional standards; floor area standards; setback requirements; density standards; parking, loading and landscaping requirements; and similar requirements. Modifications or waivers shall be justified by the applicant and shall be based upon findings that topographic conditions, existing trees and other vegetation, proposed land grading and plant materials or other site conditions perform the same functions as the required yards.

Such departures may be approved only on the condition that they will result in a higher quality of development than would be possible using conventional zoning standards. Such modifications or waivers shall be clearly shown on the approved site plan.

- f. **Setbacks from Residential Buildings.** The distance of any residential building to a nonresidential building shall not be less than one hundred (100) feet unless waived by the Village Council after recommendation by the Planning Commission.
- g. **Parking and Loading Requirements.** Parking and loading/unloading requirements set forth in Article VI - Off Street Parking and Loading Requirements, shall apply except that the number of spaces required may be reduced in a Planned Unit Development, if approved by the Village Council, upon recommendation of the Planning Commission, as part of the site plan. Such reduction shall be justified by the applicant and shall be based upon a finding that sufficient parking will be available through the sharing of spaces by different uses, that the parking requirement is excessive for the type of use proposed or similar factors.
- h. **Greenbelt.** A greenbelt at least fifty (50) feet wide shall be required along the perimeter of the Planned Unit Development (PUD). Such greenbelts shall be landscaped with trees, shrubs, berms, ground covers, and other materials in accordance with the provisions of Article IV - General Provisions. The Village Council, upon the recommendation of the Planning Commission may modify the required buffer width after concluding that the PUD meets one (1) or more of the following criteria:
 - 1. The development will be compatible with and sensitive to adjacent properties.
 - 2. The site contains natural existing vegetation and/or topography or other conditions which offer screening consistent with the standards set forth in this Ordinance.
 - 3. The arrangement, design, and orientation of buildings on the site lend to minimize the negative impacts of the development.
- i. **Required Yards and Common Areas.** All required yards and common areas shall be landscaped and adequately and permanently maintained by the property owner, tenant, or organization responsible for maintaining common areas.

Through an irrevocable conveyance, such as deed restrictions or covenants that run with the land, the developer shall assure that all yards and common areas will be developed in accordance to the site plan and never changed to another use. Such conveyance shall:

- 1. Provide for the privately owned open space to be maintained by private property owners with an interest in the open space. Maintenance standards and a maintenance schedule shall be included.
- 2. Provide for assessment of the private property owners by the Village of Leonard for the cost of maintenance of the open space in the event that it is inadequately maintained and becomes a public nuisance.

- j. **Open Space Requirements.** A Planned Unit Development, which contains single family residential uses, shall provide and maintain usable open space, accessible to all residents of the PUD. Such open space shall be designed to achieve one (1) or more of the following objectives:
 - 1. Preservation of distinctive natural features and rural characteristics.
 - 2. Preservation of land devoted to agricultural use.
 - 3. Minimization of impact from development on wetlands, woodlands, or other environmentally sensitive areas.
 - 4. Maintenance of rural open space character along major thoroughfares.
- k. **Residential Density.** The Village Council, upon the recommendation of the Planning Commission, may increase the overall density that would otherwise be permitted upon a determination that significant natural features would be preserved that would be lost if the site were developed under conventional Zoning Regulations. The Planning Commission or the Village Council may require a conceptual plan, which illustrates that, the number of units the applicant proposes would be possible under a more traditional design.
- l. **Storm Drainage.** Each site in a Planned Unit Development shall be provided with adequate storm drainage and meet all applicable local, county, state and federal laws.
- m. **General Provisions.** A Planned Unit Development shall comply with the provisions in Article IV - General Provisions.
- n. **Additional Considerations.** During review of a proposed Planned Unit Development, the Planning Commission shall take into account the following considerations, which may be relevant to a particular project: perimeter setbacks and berming; thoroughfares; drainage and utility design; underground installation of utilities; insulating the pedestrian circulation system from vehicular thoroughfares and ways; implementation of a greenway or trail system or other improvements for the public benefit; achievement of an integrated development with respect to signage, lighting, landscaping and building materials; and noise reduction and visual screening mechanisms, particularly in cases where non-residential uses adjoin off-site residentially-zoned property.
- o. **Timetable for Construction.** A timetable for construction for a Planned Unit Development and any phase of a PUD shall be included as part of the review and approval process. In accordance with Article IV – General Provisions, the Village may require that a performance guarantee be posted by the developer to assure compliance with the construction timetable. Unapproved deviations or delays in the timetable during construction may result in a loss of all or a portion of the performance guarantee.

Section 16.04 – Reserved

Section 16.05 – Pre-Application Conference (Optional)

- a. A potential applicant for a Planned Unit Development classification may request a pre-application conference prior to filing an application. The request shall be made to the Village Clerk, who shall set a date and shall inform the Village President and the Chairperson of the Village Planning Commission of the pre-application conference and invite their attendance. The Village Clerk shall also invite other officials, consultants, or staff who might have an interest in the proposed development, or who might assist the Village in the review process.
- b. The applicant shall present at such a conference, at minimum, proof of interest in the property, a sketch plan of the proposed Planned Unit Development (drawn to scale); a legal description of the property in question; the total number of acres in the project; floor area of single family, multi-family, and areas to be designated as common areas or open space.
- c. The purpose of the meeting is to inform Village and other Officials of the concept of the proposed development and provide the potential applicant with information regarding land development policies, procedures, standards and requirements of the Village in terms of the proposed development. To this end, the applicant is encouraged to present schematic plans, site data, and other information that will explain the proposed development.
- d. Statements made at the pre-application conference shall not be legally binding commitments.

Section 16.06 – Application Procedures

Application for Planned Unit Development classification shall be for an amendment to the Village Zoning Map. An application for a Planned Unit Development classification shall be filed with the Village Clerk, who shall forward the information to the Planning Commission. This application shall contain the following:

- a. Cover letter signed by the applicant and owner(s) holding an equitable interest in the property.
- b. Legal description showing the location and acreage of the property.
- c. General description of proposed development, including a timetable of development.
- d. Site plan at a scale of 1" – 100' or larger, prepared in accordance with Article XXV - Site Plan Review. Additional information on the site plan shall include:
 1. A proposed schedule of usable floor areas and land areas by category of use and building ground coverage.

2. Areas preserved for open space, indicating the proposed improvements.
 3. Architectural sketches showing building heights, external wall finishes, location of entryways, and loading and unloading facilities.
 4. Other information deemed pertinent to the proposed development by the Planning Commission or Village Council.
- e. A fee for the processing of the Planned Unit Development application, as established by the Village Council.

Section 16.07 – Review and Standards for Approval

The review and approval process for a Planned Unit Development shall be as follows:

- a. **Planning Commission Review.** The Planning Commission shall review the application and determine whether or not the proposed development best serves the intent of this Ordinance, and the public, health, safety, and welfare. Standards for review shall include:
 1. **Public, Health, Safety, and Welfare.** The public, health, safety, and welfare will be better served by this development. In making such findings, the following shall be considered: location, density of population, adequacy of schools, public facilities, hours of operation, traffic volumes and circulation, compatibility with existing development, adequate provisions for light and air, and accessibility for police and fire protection.
 2. **Compatibility with Master Plan.** The proposed development shall not have an adverse impact upon the Master Plan of the Village, and shall be consistent with the intent and spirit of this Article.
 3. **Economic Impact.** The proposed development shall not result in an unreasonably negative economic impact upon surrounding properties.
 4. **Compatibility with Adjacent Uses.** The proposed Planned Unit Development shall set forth specifications with respect to height, setbacks, density, parking, circulation, landscaping, views, and other design and layout features, which exhibit due regard for the relationship of the development to surrounding properties and the uses thereon. Consideration shall be given to:
 - (a) The bulk, placement, and materials of construction of proposed structures.
 - (b) The location and screening of vehicular circulation and parking areas in relation to surrounding development.
 - (c) The location and screening of outdoor storage, outdoor activity or work areas, and mechanical equipment in relation to surrounding development.

- (d) The hours of operation of the proposed uses.
 - (e) The provision of landscaping and other site amenities.
5. **Public Services.** The proposed Planned Unit Development shall not exceed the capacity of existing and available public services, including but not necessarily limited to utilities, public roads, police and fire protection, schools; unless the proposal contains an acceptable plan for providing necessary services or evidence that such services will be available by the time the PUD is completed.
6. **Impact of Traffic.** The Planned Unit Development shall be designed to minimize any adverse impact of traffic generated by the proposed development. Consideration shall be given to:
- (a) Estimated traffic to be generated by the proposed development.
 - (b) Access to major thoroughfares.
 - (c) Proximity and relation to intersections.
 - (d) Adequacy of driver sight distances.
 - (e) Location of and access to off-street parking.
 - (f) Required vehicular turning movements.
 - (g) Provisions for pedestrian traffic.
 - (h) Access to loading and unloading areas.
7. **Compliance with Applicable Regulations.** The proposed Planned Unit Development shall be in compliance with all applicable Federal, State, County and local laws and regulations.
8. **Phasing.** Where a project is proposed for construction in phases, the project shall be so designed that each phase, when completed, shall be capable of standing on its own in terms of the presence of services, facilities, and open space, and shall contain the necessary components to insure protection of natural resources and the health, safety, and welfare of the users of the Planned Unit Development and the residents of the surrounding area.
9. **Innovative Design.** The Planned Unit Development shall provide for extraordinary design excellence including but not limited to energy-efficient or other innovative design, open space, additional improvements to assure vehicular and pedestrian safety, and/or additional landscaping or other site features to assure a long term aesthetically pleasing appearance.

10. **Community Character.** The Planned Unit Development shall provide for land and/or facilities that contribute to and/or enhance community character, examples of which include but are not limited to parks, schools, community centers, and civic buildings.
11. **Preservation.** If the property contains existing structures deemed by the Village to be of historic, cultural, or architectural significance (such as farm structures), and where those structures are deemed by the Village to be suitable for rehabilitation, those structures shall be retained, preserved, and included within the Planned Unit Development.
12. **Environmental Impact Assessment.**
 - (a) An environmental impact assessment, in accordance with Article XXV - Site Plan Review, may be required by the Planning Commission or the Village Council
 - (b) All required environmental impact assessments shall be furnished by the applicant at the applicants' sole expense.
- b. **Public Hearing.** The Planning Commission shall schedule a hearing on the proposed Planned Unit Development and Zoning Amendment. Notice of the Public Hearing shall be provided as set forth in Article XXII - Administration and Enforcement of this Ordinance.
- c. **Planning Commission Recommendations.** At the Public Hearing or within a reasonable time following the Public Hearing, the Planning Commission shall make its final consideration of the request, and shall recommend to the Village Council denial, approval, or approval with conditions, of the request. The Planning Commission shall have prepared a report stating its conclusions, the basis for its recommendations, and any conditions relating to an affirmative recommendation. The Planning Commission shall also make a recommendation on the proposed Zoning Amendment. The Public Hearing held pursuant to this subsection shall also serve as the Public Hearing for the proposed Zoning Amendment.
- d. **State and County Approvals.** All Planned Unit Development projects shall require the review and approval of the following agencies prior to final Site Plan approval:
 1. The Oakland County Water Resource Commissioner.
 2. The Oakland County Health Division, if deemed necessary by the Planning Commission.
 3. The Michigan Department of Environmental Quality, if the project is located within their jurisdiction.
- e. **Village Council Action.** The Village Council shall be provided with a copy of the Planning Commission's report, a summary of comments received at the Public Hearing,

minutes of all proceedings, and all documents related to the Planned Unit Development. Within a reasonable time of the action of the Planning Commission, and after all approvals under subsection (d) above are obtained, the Village Council shall deny, approve, or approve with conditions, the request. The Council shall prepare a report stating its conclusions on the PUD application, the basis for its decision, the decision, and any conditions relating to an affirmative decision.

In accordance with Article IV – General Provisions, the Village Council shall require that a performance guarantee be deposited with the Village to insure faithful completion of improvements. In no event shall the performance bond be less than the estimate cost of completion, and such bond shall be posted with the Village of Leonard by a licensed Michigan insurance bonding company. Improvements shall mean those features and actions associated with the project which are considered necessary by the Village Council to protect natural resources, or health, safety, and welfare of the residents of the Village and future users or inhabitants of the proposed development, including roadways, lighting, utilities, sidewalks, screening, landscaping, and drainage.

- f. **Signed Agreement.** If the application and Site Plan are approved by the Village Council, the applicant and all owner(s) of record or the legal representative of the owner(s) of record of all property included within the Planned Development shall then sign an agreement that the approved application and Site Plan, and the conditions of approval, shall be binding upon the applicant and owner(s) of record and upon their heirs, successors, and assigns. The application and Site Plan shall not be officially approved nor may the building permit be issued, until said agreement has been signed as required herein and has been received by the Village Clerk.
- g. **Designation on Zoning Map.** Within three (3) days of the official approval of the application and, the Site Plan by the Village Council, the Village Clerk shall attest the Planned Unit Development designation for the lot in question on the Zoning Map.
- h. **Recorded with Register of Deeds.** The approved Site Plan and signed agreement shall be recorded by the petitioner with the Oakland County Register of Deeds within ten (10) days of the date of approval of the application. The petitioner shall immediately provide a certified copy of the recorded documents to the Village Clerk.

Section 16.08 – Enforcement

The Village Council may enforce any or all provisions of the approved site plan and agreement, and conditions of approval, against the petitioners, owners, successors, assigns, or agents.

Each phase of the project shall be commenced within twenty-four (24) months of the schedule set forth on the approved plan for the Planned Unit Development. If construction is not commenced within the required time period, approval of the plan shall become null and void. Revisions to the construction schedule may be approved by the Village Council.

Section 16.09 – Revision of Approved Plans

- a. **General Revisions.** Approved final plans for a Planned Unit Development may be revised in accordance with the procedures for new applications as set forth in this Article.
- b. **Minor Changes.** Notwithstanding sub-section (a) above, minor changes may be permitted by the Planning Commission following normal Site Plan review procedures outlined in Article XXV - Site Plan Review, subject to its finding that:
 1. Such changes will not adversely affect the initial basis for granting approval.
 2. Such minor changes will not adversely affect the overall Planned Unit Development in light of the intent and purpose of such development as set forth in this Article.

ARTICLE XVII

PR - PARKS AND RECREATION DISTRICT

Section 17.01 – Statement of Purpose

The Parks and Recreation District is established for the purpose of reserving lands for public recreation as well as for public and commercial amusement purposes. District regulations are intended to conserve open space and natural amenities including wetlands, woodlands, floodplains, wildlife habitat and other natural features, to allow and regulate the use of such areas for recreational enjoyment, and to regulate the use, improvement and development of such lands in a matter that safeguards natural amenities from undesirable influences.

Section 17.02 – Permitted Principal Uses

In the Parks and Recreation District, the following uses shall be permitted:

- a. Public uses such as parks, playgrounds, and playfields, natural open spaces, and publicly owned conservation land and parks.
- b. Parking for permitted uses.

Section 17.03 – Permitted Uses after Special Approval

- a. Temporary food or concession stands.
- b. Carnivals, art fairs, civic events.
- c. Parking for permitted uses after Special Approval.
- d. Structures accessory to special Approval Uses.

Section 17.04 – Area, Height, Bulk and Placement Requirements

- a. Minimum lot size and width - No minimum.
- b. Minimum yards - Same as R-1 - Single Family Zoning District.
- c. Maximum building height - Twenty-seven (27) feet.

Section 17.05 – Site Plan Review

In accordance with Article XXV - Site Plan Review, the construction of a building or off-street parking shall undergo Site Plan Review by the Village Planning Commission.

Section 17.06 – Environmental Impact Assessment

- a. An environmental impact assessment, in accordance with Article XXV - Site Plan Review, may be required by the Planning Commission or the Village Council.
- b. All required environmental impact assessments shall be furnished by the applicant at the applicants' sole expense.

ARTICLE XVIII - SCHEDULE OF REGULATIONS

Section 18.01 - Area, Height, Bulk and Placement Requirements for all Zoning Districts

Zoning Districts	Lot Minimums		Maximum Building Height		Maximum Coverage by all Buildings %	Minimum Setback (Feet)				Minimum Gross Floor Area Per Dwelling Unit (Sq. Ft.)
	Area	Width (Ft)	In Stories	In Feet		Front Yard	Side Yards		Rear Yard	
							Least One	Total of Two		
AG - Agriculture	5 Acres	300	2.5	27 a	10	25	15	30	50	850
R-1F - Small Farm	2 Acres	150	2.5	27	15	45	15	30	50	850
R-1 - Single Family Residential	1 Acre	120	2.5	27	25	45	15	30	40	850
R-2 - Single Family Residential	20,000 Sq. Ft.	100 b	2.5	27	30	40 b	12 b	30 b	35 b	850
MD - Multiple Family Residential	c	100	2.5	27	30	30	15 e	30 e	30 e	d
C-1 - Village Commercial	f	m	2.0	27	30	g	h	h	i	N/A
LI - Limited Industrial	f	150	2.0	30	40	50	20	40	30	N/A
PR - Parks and Recreation	N/A	N/A	N/A	27	N/A	45	15	30	40	N/A

Note: See Section 18.02 - Notes to Schedule of Regulations for Regulations Assigned to letters

ARTICLE XVIII

SCHEDULE OF REGULATIONS

Section 18.02 – Notes to Schedule of Regulations

- a. Maximum height of non-residential agricultural structures shall not exceed fifty (50) feet.
- b. In accordance with Article V - Non-Conformities, Substandard Residential Lots in R-2 residential districts may have minimum requirements as follows:
 - 1. Yard Requirements
 - Front Yard.....25 feet
 - Rear Yard.....25 feet
 - Side Yard10 feet, total of both yards 20 feet
 - 2. Lot width.....50 feet
- c. Minimum land area required for each multiple family project shall be 20,000 square feet plus the additional land area requirements per dwelling unit as listed in the following schedule:

<u>Dwelling Unit Size</u>	<u>Land Area In Square Feet</u>
Efficiency or one (1) bedroom unit	6,000
Two (2) bedroom unit	8,000
Three (3) bedroom unit	10,000
Four (4) bedroom unit*	12,000

*Plus 2,000 square feet for each bedroom over four (4) bedrooms in the dwelling unit

A den, library or extra room shall be counted as a bedroom for purposes of this Ordinance. Notwithstanding the foregoing, the overall density shall not exceed five (5.0) dwelling units per acre for any development in the Article X - Multiple Residential District.

- d. In the multiple dwelling zone, every residential building erected or converted hereafter shall provide at least the following minimum floor areas:

<u>Dwelling Unit Size</u>	<u>Area</u>
Efficiency Unit.	350 square feet
One (1) bedroom unit.	600 square feet
Two (2) bedroom unit.	750 square feet
Three (3) bedroom unit.	850 square feet
Four (4) bedroom unit*	1,000 square feet

*Plus 150 square feet for each bedroom over four (4) bedrooms in the dwelling unit.

- e. No building except carports shall be located less than thirty (30) feet from the boundary of the R-1, R-2, or R-1F Districts.
- f. Every lot in the C-1 and LI Districts, used as a business, shall have an area sufficient in size to comply with the requirements pertaining to the particular use with an adequate and safe water supply and a safe and adequate sewage disposal system as established by standards required by the State or County Health Department rules and regulations.
- g. Buildings shall have a minimum of 0 feet setback from the front street right-of-way line and a maximum of ten (10) feet setback from the street right-of-way line.
- h. Side yards are not required along interior side lot lines if all walls abutting or facing such lot lines are of fireproof masonry construction and entirely without windows or other openings. A side yard of twenty (20) feet is required whenever adjacent to a residential district.
- i. No rear yard is required in the C-1 District where the rear property line abuts upon a public alley.
- j. Interior side yards may not be required in industrial parks, shopping centers or other combined development, which uses a common driveway and off-street parking system.
- k. In all residential and industrial districts, the required front yard shall not be used for off-street parking, loading, or unloading, and shall remain as open space unoccupied and unobstructed from the ground upward except for landscaping, plant materials or vehicle access drives.
- l. Sidewalks are required for all new construction on Public Roads in Residential, Industrial, Commercial and Agriculture Districts within the road easement. Sidewalks are to be a minimum of five (5) feet wide.
- m. Lots one acre and larger shall have a minimum lot width of one hundred fifty (150) feet. Lots smaller than one acre shall have a minimum lot width of one hundred (100) feet.

ARTICLE XIX

SIGNS

Section 19.01 – Statement of Purpose

The purpose of this Article is to regulate signs and outdoor advertising within the Village of Leonard to protect public safety, health and welfare; recognize the different visual environments within the Zoning Districts; minimize abundance and size of signs to reduce motorist distraction and loss of visibility; promote public convenience; preserve property values; support and complement strategies of the Village of Leonard Master Plan and this Ordinance; and enhance the aesthetic appearance and quality of life within the Village.

Section 19.02 – Definitions

A sign is any device, structure, fixture, figure, symbol, banner, pennant, flag, balloon, logo, or placard consisting of written copy, symbols, logos and/or graphics, designed for the purpose of bringing attention to, identifying or advertising an establishment, product, goods, services, or other message to the general public. Various types of signs and sign-related terms are defined below:

- a. Banner Sign: Fabric, plastic or other sign made of non-rigid material without enclosing structural framework.
- b. Billboard: See off-premise sign.
- c. Canopy Sign: A non-rigid fabric marquee or awning-type structure, which is attached to the building by supporting framework, which includes a business identification message, symbol, and/or logo.
- d. Changeable Message Sign: A permanent reader board attached to a pylon sign or the exterior of a wall where copy is changed mechanically, electronically or manually, including time/temperature signs.
- e. Construction Sign: A sign identifying the name(s) of project owners, contractors, developers, architects, designers, engineers, landscape architects, and financiers of a project being constructed or improved; and not including any advertising of any product or announcement of availability of leasing space.
- f. Directional Sign: A sign which assists motorists in determining or confirming a correct route, specifically enter, exit and parking signs.
- g. Ground Sign: A freestanding sign supported by one (1) or more pole(s), post(s), brace(s) in the ground surface, or a monument.

- h. Off-Premise Sign: A sign which identifies a use or advertises products and services not available on the site or lot on which the sign is located; a sign which directs travelers or provides a message unrelated to the site on which the sign is located (e.g. billboards).
- i. On-Premise Sign: A sign providing the address and name of owner of a parcel of land; a sign advertising a business, service or product sold or produced on the same site or parcel.
- j. Political Sign: A temporary sign used in connection with local, state, or national elections or referendums.
- k. Portable Sign: A sign designed to be moved from place to place, whether or not it is permanently attached to the ground or a structure. This includes hot-air and gas filled balloons, pennants, streamers, ribbons, pinwheels, non-governmental flags, searchlights and signs mounted on a portable structure; but excludes political signs, real estate signs, construction signs, permanent changeable message signs, and regulatory/government signs.
- l. Projecting Sign: A sign, other than a wall sign, that is affixed to any building or wall and whose leading edge extends more than twelve (12) inches beyond such building or wall.
- m. Pylon (Pole) Sign: A sign supported on the ground by a pole, brace, or monument, and not attached to any building or other structure.
- n. Real Estate Sign: An on-premise temporary sign advertising the property or structures availability for sale or lease.
- o. Regulatory Sign: A sign installed by a public agency to direct traffic flow, regulate traffic operations and provide information in conformance with the Michigan Manual of Uniform Traffic Control Devices.
- p. Temporary Sign: A sign not constructed or intended for long term use. Examples of temporary signs include signs, which announce a coming attraction, a new building under construction, a community or civic project, or other special events that occur for a limited period of time.
- q. Wall Sign: A sign placed flat, adjacent to the building, extending from the building as a canopy sign or projecting sign, or placed on a separate canopy such as over gasoline pumps.
- r. Window Sign: A sign located in or on a window, which is intended to be viewed from the outside. Permanent window signs, which are not affixed directly to a window or are positioned next to a window so that they are visible from the outside, shall be considered wall signs.

Section 19.03 – Exempt Signs

A sign permit shall not be required for the following signs, which shall be permitted subject to applicable provisions herein:

- a. Address, owner or occupant nameplate and other signs of up to two (2) square feet in area attached to a mailbox, light fixture or an exterior wall.
- b. Names of buildings, dates of erection, monumental citations, commemorative tablets when carved into stone, concrete, or similar material which are part of the construction of the building.
- c. Home occupation identification sign, provided that it is a legal home occupation in a residential district, that there is only one (1) sign per parcel, attached to an exterior building wall, and does not exceed one (1) square foot in area.
- d. Construction signs provided that there shall be only one (1) such sign per development project; with a maximum height of six (6) feet; not exceeding sixteen (16) square feet in area and setback a minimum fifteen (15) feet from any property line or public street right-of-way; and that such signs shall be erected during the construction period only and shall be removed within fourteen (14) days of the date an occupancy permit is issued.
- e. Garage sale and estate sale signs announcing the sale of household goods, provided that: there is only one (1) sign per premises; that they are on-premise only, entirely on private property; that they do not exceed six (6) square feet in area; and that they erected no more than five (5) business days before and are removed within one (1) business day after the announced sale.
- f. Historical markers, plaques or signs describing State or National designation as an historic site or structure and/or containing narrative, not exceeding twelve (12) square feet in area.
- g. Signs not exceeding a total of two (2) square feet per business indicating acceptance of credit cards or describing business affiliations and are attached to a permitted sign, exterior wall, building entrance or window.
- h. Signs on vending machines, gas pumps, and ices containers indicating the contents, Provided that the sign on each device does not exceed two (2) square feet in area.
- i. Signs atop gasoline service station pumps announcing on-premise sales, provided that such signs not exceed two (2) square feet in area and signs on gas station pump islands or their structural supports identifying “self-serve” and “full-serve” operations.
- j. Non-commercial signs: signs containing non-commercial messages, such as those designating the location of public telephones, restrooms, restrictions on smoking and restrictions on building entrances, provided that such signs do not exceed two (2) square feet in area.

- k. Flags or insignia of any Nation, State, the Village, community organization, educational institution, non-commercial enterprise, college, or university.
- l. Political Signs: Political signs shall be permitted subject to the following conditions:
 - 1. Maximum Area and Number: No more than four (4) political signs shall be placed on any premises. Political signs shall not be located closer than fifteen (15) feet to the edge of the traveled portion of the roadway and not in a dedicated right-of-way or attached to any utility pole. Political signs shall be ground or wall signs. No ground sign shall be higher than forty-eight (48) inches above average mean grade of the yard on which it is placed.
 - 2. Political signs shall be removed within ten (10) calendar days after the election or event to which it relates. Signs that express an opinion unrelated to an election date are limited to a period of display not to exceed thirty (30) days (whether consecutive or not) in one (1) calendar year on any premises.
 - 3. Political signs shall not be erected in such a manner that they will or reasonably may be expected to interfere with, obstruct, confuse, or mislead traffic.
- m. Real estate signs, provided that there shall be only one (1) real estate sign per parcel for each public street frontage, such signs are setback a minimum of fifteen (15) feet from any property line or public right-of-way, that the maximum height of any such sign shall be six (6) feet, and such signs shall not exceed six (6) square feet in area within the residential districts, twelve (12) feet in area for all other districts.
- n. Regulatory, directional, and street signs erected by a public agency in compliance with Michigan Manual of Uniform Traffic Control Devices Manual.
- o. Window signs within the building, provided that such signs do not occupy more than fifty percent (50%) of the window area and the clear window portion is located to allow security monitoring from the street.
- p. Warning signs, such as no trespassing, warning of electrical currents or animals, provided such signs do not exceed two (2) square feet in area.
- q. Community special event signs, including ground or wall signs, banners, pennants, or similar displays; the number, size, height, and duration of display of such signs shall be subject to Planning Commission approval.

Section 19.04 – Prohibited Signs

The following signs shall be prohibited in any Zoning District:

- a. Signs which obstruct free access to or egress from any building.
- b. Signs which in any way simulate or could be confused with the lighting of emergency vehicles or traffic signals.

- c. Signs which obstruct or impair the vision of motorists or non-motorized travelers at any intersection, driveway, within a parking lot or loading area.
- d. Signs having moving members or parts, or using high intensity or flashing lights, spinners or animated devices.
- e. Non-regulatory signs placed in any public right-of-way, attached to a utility pole or affixed to a tree.
- f. Portable signs, as defined, unless otherwise provided for in this Ordinance.
- g. Signs erected upon or applied to any building roof.

Section 19.05 – General Standards for Permitted Signs

Signs which are permitted as accessory uses serving a commercial or informational purpose may be permitted subject to the requirements of this Article; provided, that no such sign shall be erected or altered until approved by the Village.

- a. **Restrictions on Movement:** It is unlawful to erect or maintain any sign, except a cloth flag moved only by natural wind, which moves or has any visible moving or animated parts or image, whether movement is caused by machinery, electronics or otherwise, including swinging signs. It is unlawful to erect or maintain strings of flags or streamers.
- b. Sign location shall ensure adequate sight distance.
- c. Illumination of signs shall be directed or shaded downward, so that no direct rays from such illumination shall interfere with the vision of persons on the adjacent streets or of adjacent property owners. The use of colored lights, which might be confused with traffic signals, will not be permitted. Underground wiring shall be required for all illuminated signs not attached to a building. Back lit and neon tube signs shall not be permitted.
- d. No sign shall project farther than fifteen (15) inches beyond the face of the building façade, provided that where a sign extends more than three (3) inches from the building façade, the bottom of the sign shall be at least ten (10) feet from the ground and except as otherwise specifically permitted in subsections (f) & (h) below.
- e. The width of a wall or canopy sign shall not exceed ninety percent (90%) of the width of the building façade upon which it is located.
- f. **Hanging signs in the C-1 District:** Signs may be permitted on the face or underside of a canopy in the Village Commercial District, subject to the approval of the Building Official who shall insure that the location, size, and type of such sign are consistent with other similar signs in the downtown.

- g. Billboards: Only one (1) billboard shall be permitted per lot. All billboard signs shall be set back seventy-five (75) feet from any public right-of-way and shall be located only in the LI District and may not exceed one-hundred (100) square feet in area.
- h. Projecting or canopy signs in the C-1 District shall be setback at least two (2) feet from any street curb line, shall not extend more than four (4) feet over the public right-of-way, and shall leave a minimum clearance of eight (8) feet above the ground.

Projecting or canopy signs in all other Zoning Districts shall have a minimum ground clearance of ten (10) feet, shall be setback at least six (6) feet from any adjacent public right-of-way, and shall not project over an alley or private access lane. No projecting sign shall extend for more than four (4) feet from the building to which it is attached.
- i. No more than one (1) directional sign shall be permitted per approved driveway, with a maximum sign area of four (4) square feet per sign, and a maximum height of four (4).
- j. No sign shall extend above the roof or parapet of the structure to which it is attached by more than one (1) foot.
- k. One (1) permanent sign per vehicular entrance, identifying residential developments such as subdivisions, apartment complexes, condominium communities, senior housing complexes, mobile home parks and similar uses, provided that the sign is setback a minimum of fifteen (15) feet from any property line or public right-of-way; has a maximum height of six (6) feet; and does not exceed twenty-four (24) square feet in area.
- l. Measurement of allowable pylon sign area: The allowable area for signs shall be measured by calculating the square footage of the sign face and any frame of other material or color forming an integral part of the display or used to differentiate it from the background against which it is placed as measured by enclosing the most protruding points or edges of a sign within a parallelogram or rectangle. Back-to-back sign faces shall be counted as one (1) sign face for the purposes of measurement.
- m. Measurement of allowable sign area for wall signs: Wall sign square footage shall be determined by measuring a box, which includes the portion of the canopy, which contains a message, symbol, and/or logo. When a sign consists solely of lettering or other unifying elements printed, painted or mounted on a wall of a building without any distinguishing border, panel, or background, the calculation for sign area shall be measured by enclosing the most protruding edges of the sign elements within a box.
- n. Obsolete Signs. It is unlawful to maintain for more than thirty (30) days any sign, which has become obsolete because of discontinuance of the business, service, or activity. The fact that an obsolete sign is non-conforming shall not be construed as modifying any of the requirements of this Section.
- o. Permission of Owner or Occupant. It is unlawful to erect or maintain any sign on any property, public or private, without the consent of the owner or occupant thereof.

- p. Exceptions: Sub-sections a. and c. shall not be applied to prevent the erection or maintenance of Christmas lights each year or signs which convey changing information such as time or temperature.
- q. Temporary signs (other than political signs) and Portable Signs shall be authorized by the Building Official for not more than two (2) months at a time by written permit which shall show the size, shape, content, height, number, type of construction, area and location of such signs and the period during which authorized, upon a finding by the Building Official, on the basis of written information furnished by the applicant that the proposed sign or signs are for the direction and/or information of the public and not contrary to the spirit and purpose of this Ordinance, and upon payment of a fee set by the Village Council for each permit and renewal. If such signs are placed on public right-of-way property, the Building Official shall remove them forthwith and without notice. Temporary signs shall not exceed six (6) square feet in area.

Section 19.06 – Reserved

Section 19.07 – District Regulations

- a. **Signs Permitted in the AG District:** On-premise signs are permitted having an area not exceeding one (1) square foot for each ten (10) feet of street frontage with a maximum of sixteen (16) square feet.
- b. **Signs Permitted in the R-1F, R-1, R-2, and MD Districts:** One sign identifying each subdivision, or multiple family complex, per vehicle entrance, having an area not exceeding twenty (20) square feet and a height not exceeding six (6) feet, is permitted. During development of a subdivision or other property for a period not exceeding two (2) years, one sign, having an area not exceeding thirty-two (32) square feet and a height not exceeding eight (8) feet, is permitted in the subdivision, together with signs having an area not exceeding six (6) square feet each a height not exceeding six (6) feet, directing the public to or identifying models.
- c. **Signs Permitted in the C-1 District:** On-premise signs are permitted having an area not exceeding two (2) square feet for each ten (10) feet of street frontage. Where any premises have more than one occupant, permitted area shall be divided among them in the same proportion as floor space and outdoor sales space is occupied by them. The height and setback rule pertaining to buildings are applicable to signs. Total area for all signs for each lot shall not exceed seventy-five (75) square feet.
- d. **Signs Permitted in the LI District:** On-premises signs are permitted having an area not exceeding three (3) square feet for each ten (10) feet or fraction thereof of street frontage. Total sign area for a lot shall not have an area exceeding one hundred (100) square feet. Where any premises have more than one occupant, the total permitted sign area shall be divided among the occupants in the same proportion as floor space and outdoor sales space on the premises is occupied by them. Where the premises has more than two occupants and has a name district from that of any occupant, such as in a shopping center, an additional one (1) square foot of sign area for each ten (10) feet of fraction thereof of

street frontage, with a maximum of thirty (30) square feet shall be subject to the height and setback rules applicable to buildings in the zoning district where located.

Section 19.08 – Non-Conforming Signs

- a. It is intended to eliminate nonconforming signs, except as otherwise specifically set forth in this Section. Any lawfully erected sign and maintenance of which is made unlawful by this Ordinance may continue to be maintained exactly as such existed at the time when the maintenance thereof became otherwise unlawful under the provisions of this Ordinance.
- b. No non-conforming sign:
 1. Shall be changed to another non-conforming sign; or
 2. Shall have any changes made in the words or symbols used or for message displays on the sign unless the sign is an off-premises advertising sign, or a bulletin board, or a substantially similar type of sign, specifically designed for periodic change of message; or
 3. Shall be structurally altered so as to prolong the life of the sign or so as to change the shape, size, type or design of the sign; or
 4. Shall be re-established after the activity, business or usage to which it relates has been discontinued for sixty (60) days or longer; or
 5. Shall be re-established after damage or destruction if the estimated expense of reconstruction exceeds fifty (50%) percent of the reproduction cost.

Section 19.09 – Sign Permits

Sign permits shall be obtained from the Village Clerk prior to the erection or replacement of any regulated sign. The fee for a Sign Permit shall be established, and may be periodically changed, by resolution of the Village Council.

ARTICLE XX

OUTDOOR LIGHTING

Section 20.01 – Statement of Purpose and Intent

- a. The use of outdoor lighting is often necessary for adequate night time safety and utility, but common lighting practices can also interfere with other legitimate public concerns. Principal among these concerns are:
 - 1. The degradation of the night time visual environment by production of unsightly and dangerous glare.
 - 2. Unnecessary waste of energy and resources in the production of too much light or wasted light.
 - 3. Interference in the use or enjoyment of property which is not intended to be illuminated at night.
 - 4. The loss of the often-neglected scenic view of the heavens due to increased urban sky-glow. It is hereby recognized that these different interests, those of safety and utility and those of aesthetic appearance, need not compete. Good modern lighting practices can provide adequate light for safety and utility without excessive glare or light pollution. In nearly all cases, careful attention to questions of when and where and how much night time lighting is needed will lead to better lighting practice for all viewpoints.
- b. Accordingly, it is the intent of this Article to encourage lighting practices and systems which will minimize light pollution, glare, light trespass, and conserve energy while maintaining night time safety, utility, security, and productivity.

Section 20.02 – Definitions

- a. **Abandonment** means the discontinuation of use for a period of six (6) months.
- b. **Class 1 Lighting** means all outdoor lighting used for, but not limited to outdoor sales or eating areas, assembly or repair areas, advertising and other signs, recreational facilities and other similar applications where color rendition is important to preserve the effectiveness of the activity. Designation of Class 1 Lighting requires a finding by the Building Official of the essential nature of color rendition for the application. Recognized as Class 1 uses are outdoor eating and retail food or beverage service areas; outdoor maintenance areas; display lots; assembly areas such as concert or theater amphitheaters.
- c. **Class 2 Lighting** means all outdoor lighting used for but not limited to illumination for walkways, roadways, equipment yards, parking lots, and outdoor security where general illumination of the grounds for safety or security is the primary concern.

- d. **Class 3 Lighting** means any outdoor lighting used for decorative effects, including but not limited to architectural illumination, flag monument lighting, and illumination of trees, bushes, etc.
- e. **Development Project** means any residential, commercial, industrial, or mixed use subdivision or condominium plan or individual building development or remodeling plan which is submitted to the Village for approval.
- f. **Direct Illumination** means illumination resulting from light emitted directly from a lamp, luminaries, or reflector, not light diffused through translucent signs or reflected from other surfaces such as the ground or building faces.
- g. **Foot-candle** means a unit of illumination produced on a surface, all points of which are one foot from a uniform point source of one candle. It is the luminous flux per unit area in the Imperial system. One foot-candle equals approximately 10 (10.8) Lux.
- h. **Fully Shielded Fixture** means a lighting fixture constructed in such a manner that all light emitted by the fixture, either directly from the lamp or a diffusing element, or indirectly by reflection or refraction from any part of the luminaries, is projected below a horizontal plane running through the lowest point on the fixture where light is emitted. Any structural part of the light fixture providing this shielding must be permanently affixed.
- i. **Glare** means the sensation produced by a bright source within the visual field that is sufficiently brighter than the level to which the eyes are adapted to cause annoyance, discomfort, or loss in visual performance and visibility; blinding light. The magnitude of glare depends on such factors as the size, position, brightness of the source, and on the brightness level to which the eyes are adapted.
- j. **Illuminance** is the amount of light falling onto a unit area of surface (luminous flux per unit area) – measured in lumens per square meter (Lux) or lumens per square foot (foot-candles).
- k. **Installed** means attached, or fixed in place whether or not connected to a power source.
- l. **Light Trespass** is the spill light falling over property lines that illuminates adjacent grounds or buildings in an objectionable manner.
- m. **Lumen** is the unit used to measure the actual amount of visible light, which is produced by a lamp as defined by the manufacturer.
- n. **Luminaries** means the complete lighting assembly (including the lamp, housing, reflectors, lenses, and shields), less the support assembly. For purposes of determining total light output lighting fixtures that include multiple unshielded or partially shielded lamps on a single pole or standard shall be considered as a single unit.

- o. **Multi-Class Lighting** means any outdoor lighting used for more than one purpose, such as security and decoration, when those purposes fall under the definitions for two or more lighting classes as defined for Class, 1, 2 and 3 Lighting above.
- p. **Motion Sensing Security Lighting** means a fixture designed, and properly adjusted, to illuminate an area around a residence or other building by means of switching on a lamp when motion is detected inside the area or perimeter, and switching the lamp off when the detected motion ceases.
- q. **Neon Lighting** means lighting using luminous gas filled tubes often formed into text, symbols, or decorative elements. Neon Lighting includes tubes with typical diameters of ten (10) to twenty (20) millimeters filled with neon, argon, xenon, or other gasses and producing various colors of light. Not included are replaceable T-8 (1" inch diameter) and T-12 (1.5" inch diameter) or PLA (compact fluorescent tubes).
- r. **Net Acreage** means the remaining ground area of a parcel after deleting all portions for proposed and existing public rights-of-way within a development parcel or subdivision. For parcels including those special uses listed in Section 20.07(j) and (k) (recreational facilities and outdoor display lots), the area devoted to the special use shall also be excluded from the net acreage.
- s. **Outdoor Light Fixtures** means all outdoor illuminating devices, outdoor lighting or reflective surface, luminous tube, lamp or similar devices, either permanently installed or portable, which are used for illumination, decoration, or advertisement. Such devices shall include, but are not limited to lights used for:
 - 1. Parking lot lighting
 - 2. Roadway lighting
 - 3. Building and structures
 - 4. Recreational areas
 - 5. Landscape and architectural lighting
 - 6. Billboards and other signs (advertising or other)
 - 7. Product display area lighting
 - 8. Building or structure decoration
 - 9. Building overhangs and open canopies
 - 10. Security lighting

- t. **Outdoor Recreation Facility** means an area designed for active recreation, whether publicly or privately owned, including but not limited to parks, baseball diamonds, soccer and football fields, golf courses, tennis courts and swimming pools.
- u. **Security Lighting** is lighting designed to illuminate a property or grounds for the purpose of visual security. This includes fully shielded lighting designed to be left on during night time hours as well as motion sensing lighting fixtures.
- v. **Temporary Lighting** means lighting which does not conform to the provisions of this Article and which will not be used for more than one thirty (30) day period within a calendar year. Temporary lighting is intended for uses, which by their nature are of limited duration; (e.g. holiday decorations, civic events, or construction projects.)
- w. **Total Outdoor Light Output** means the maximum total amount of light, measured in lumens, from all outdoor light fixtures on a property. For lamp types that vary in their output as they age (such as high-pressure sodium and metal halide), the initial output, as defined by the manufacturer, is the value to be considered.
- x. **Unshielded Fixture** means a fixture that allows light to be emitted above the horizontal directly from the lamp or indirectly from the fixture or a reflector.
- y. **Watt** is the unit used to measure the electrical power consumption (not the light output) of a lamp.

Section 20.03 – Conflicting Regulations

- a. In the event of conflict between the regulations set forth in this Article and any other regulations applicable to the same area, the more stringent limitation or requirement shall govern.

Section 20.04 – Reserved

Section 20.05 – Approved Materials and Methods of Construction or Installation/Operation

- a. The provisions of this Article are not intended to prevent the use of any design, material or method of installation or operation not specifically prescribed by this Article, provided the Planning Commission has approved any such alternate.
- b. The Planning Commission may approve any such proposed alternate provided that such alternate:
 1. Provides at least equivalence to the applicable specific requirements of this Article; and
 2. Is otherwise satisfactory and complies with the intent of this Article.

Section 20.06 – Preferred Source

- a. Due to their high-energy efficiency, long life, and spectral characteristics, low-pressure sodium (LPS) lamps are the preferred illumination source throughout the Village. Their use is encouraged for outdoor illumination whenever possible.

Section 20.07 – Lighting Requirements

- a. Outdoor floodlighting by flood light projection above the horizontal is prohibited except for lamps specifically exempted under Subsection k and properly adjusted motion sensing security lighting fixtures as defined herein
- b. All light fixtures which are required to be shielded shall be installed in such a manner that the shielding complies with the definition of “Fully Shielded Fixtures.”
- c. All light fixtures, including security lighting, except street lamps, shall be aimed or shielded so that the direct illumination shall be confined to the property boundaries of the source. Particular care is to be taken to assure that the direct illumination does not fall onto or across any public or private street or road. Motion sensing lighting fixtures shall be properly adjusted, according to the manufacturer’s instructions, to turn off when detected motion ceases.
- d. Search lights, laser source lights, strobe or flashing lights, motion or illusion lights or any similar high-intensity light shall not be permitted, except in emergencies by police and fire personnel at their direction or as permitted in this Article.
- e. Class 1 Lighting, including but not limited to, sales, service, commercial, assembly, repair, maintenance, and industrial areas, may only continue in operation until 10:00 pm, or for as long as the area is in active use. This provision is not applicable to fixtures lawfully installed or implemented prior to the adoption of this Article.
- f. Class 2 Lighting shall have no time restrictions except as specified by the Planning Commission for new projects.
- g. Class 3 Lighting, except for flagpole lighting, must be extinguished after 10:00 pm, or when the business closes, whichever is later, except that low-wattage holiday decorations may remain on all night from November 15 to January 15.
- h. Multi-Class Lighting, except for security lights, must conform to the time limitations of the strictest class.
- i. Except as permitted in Subsections 20.07(j), (k), and (l) below, total outdoor light output, excluding streetlights used for illumination of public rights-of-way, of any development project shall not exceed one-hundred thousand (100,000) lumens per net acre, averaged over the entire property. No more than five thousand, five-hundred (5,500) lumens per net acre may be accounted for by lamps in unshielded fixtures permitted in Subsection 20.07(o) below.

j. Lighting, in all cases, for all outdoor athletic fields, courts, tracks or ranges shall be considered Class 1 (Color Rendition). Lighting allowed in this Subsection shall be subject to approval of the Planning Commission. When the proposed lumens per acre exceeds the limits of Subsection 20.07(i) the installation shall be designed to achieve no greater than the minimum illuminant levels for the activity as recommended by the Illumination Engineering Society of North America (IESNA). The installation shall also limit off-site spill (off the parcel containing the sports facility) to a maximum of 0.5 Foot-candles at a location on any residential property, as measurable from any orientation of the measuring device. All events shall be scheduled so as to complete all activity by 10:00 pm. Illumination of the playing field, court, track or range shall be permitted after 10:00 pm only to conclude a scheduled event that was unable to conclude before 10:00 pm due to unusual circumstances. Fully Shielded lighting shall be required for fields designed for amateur, recreational or non-professional sports activity. For professional level sports facilities where fully shielded fixtures are not utilized, acceptable luminaries shall include those which:

1. Are provided with internal or external glare control louvers, or both, and installed so as to minimize up-light and offsite light trespass; and
2. Are installed and maintained with aiming angles that permit not greater than two (2%) percent of the light emitted by each fixture to project above the horizontal.

k. Lighting for Outdoor Display Lots shall be considered Class 1 (Color Rendition), and shall conform to the lumens per acre limit of Subsection 20.07 (i) except as follows:

1. All such lighting shall utilize fully shielded luminaries that are installed in a fashion that maintains the fully shielded characteristics. When the proposed lumens per acre exceed the limits of Subsection 20.07 (i) the installation shall be designed to achieve no greater than the minimum luminance levels for the activity as recommended by the Illumination Engineering Society of North America (IESNA). The installation shall also limit off-site spill (off the parcel containing the display lot) to a maximum of 0.5 Foot-candles at any location on any non-residential property, and 0.05 Foot-candles at any location on any residential property, as measurable from any orientation of the measuring device. Outdoor Display Lot lighting exceeding the lumens per acre cap of Subsection 20.07 (i) shall be turned off at 10:00 pm or within thirty (30) minutes after closing of the business or activity whichever is later. Lighting in the Outdoor Display Lot after this time shall be limited to Class 2 lighting, and shall conform to all restrictions of this Article applicable for this class, including the lumens per acre caps on Subsection 20.07 (i).
2. Lighting allowed in this Subsection shall be subject to approval of the Planning Commission.

1. Lighting for Service Station or similar canopies shall be considered Class 1 lighting. All luminaries mounted on or recessed into the lower surface of service station canopies shall be fully shielded and utilize flat glass or plastic covers. The total light output used for

illuminating service station canopies, defined as the sum of under-canopy initial bare-lamp outputs in lumens, shall not exceed forty (40) lumens per square foot of canopy. All lighting mounted under the lower surface of the canopy and any lighting within signage or illuminated panels over the pumps, is to be included toward the total at full initial lumen output. Fifty (50%) percent of the lumen output of all lamps mounted within or under a canopy, except internally illuminated signs, is included in the lumen caps in Subsection 20.07 (i).

- m. Lighting used for all illuminated signs shall comply with illumination requirements of Article XIX – Signs.
- n. All site lighting not directly associated with the special uses as permitted in Subsections 20.07 (j), (k), and (l) above shall conform to all lighting standards described in this Article.
- o. The requirements for lamp source and shielding of light emissions for outdoor light fixtures are as follows:

Shielding/Use Code: A = allowed, unshielded; F = allowed, fully shielded

-TBODY-Lamp Type Class 1, 2 and 3 lighting	Shielding
All lamp types above 2050 lumens (See Note 1)	F
All types below 2050 lumens	A (See Note 2)
All neon tube lighting	F
Lamps in Motion Sensing Security Lights	A (See 20.05(c)) - TBODY-

Note 1:

Examples of lamp types of 2050 lumens and below (the acceptability of a particular light is decided by its lumen output, not wattage. Check manufacturer’s specifications):

- 100 Watt Standard Incandescent and less.
- 100 Watt Mid-break Tungsten-Halogen (quartz) and less.
- 25 Watt T-12 Cool White Florescent and less.
- 18 Watt Low Pressure Sodium and less.

Note 2:

Lights shall be shielded whenever feasible to minimize light spilled into the night sky or adjacent properties. Unshielded lights (all types) are limited to a maximum of five thousand, five-hundred (5,500) lumens per net acre (see Subsection 20.07(i)). Residential parcels and Development Projects containing one net acre or less are allowed five thousand, five-hundred (5,500) lumens of unshielded light (all Classes).

Section 20.08 – Parking Lot Lighting Standards

- a. Lighting Standards (poles) shall be sized in such a manner that the top of any luminaries does not exceed twenty-four (24) feet above adjacent grade, unless otherwise specified by the Planning Commission for new Projects.

Section 20.09 – Reserved

Section 20.10 – Temporary Lighting Permits

- a. The Building Official may grant a permit for temporary lighting if he or she finds all of the following:
 1. The purpose for which the lighting is proposed is not intended to extend beyond thirty (30) days; and
 2. The proposed lighting is designed in such a manner as to minimize light pollution as much as is feasible; and
 3. The proposed lighting will comply with the general intent of this Article; and
 4. The permit will be in the public interest.
- b. The Building Official shall rule on the application within five (5) business days from the date of submission of the request and notify the applicant in writing of his or her decision. The Building Official may grant one (1) renewal of the permit for an additional thirty (30) days if he or she finds that, because of an unanticipated change in circumstances, renewal would be in the public interest. The Building Official is not authorized to grant more than one (1) temporary permit and one (1) renewal for the same property within one (1) calendar year.

Section 20.11 – Nonconforming Uses

- a. Mercury vapor lamps in use for outdoor lighting on the effective date of this Article shall not be so used after January 1, 2005.
- b. Bottom or side-mounted outdoor advertising sign lighting shall not be used after January 1, 2005.
- c. No outdoor lighting fixture or use which was lawfully installed or implemented prior to the enactment of this Article shall be required to be removed or modified except as expressly provided herein; however, no modification or replacement shall be made to a nonconforming fixture unless the fixture thereafter conforms to the provisions of this Article, except that identical lamp replacement is allowed.
- d. In the event that an outdoor lighting fixture is abandoned or is damaged to the point of requiring repairs for safe operation the repaired or replacement fixture shall comply with the provisions of this Article.

Section 20.12 – Variances

- a. Pursuant to the provisions of Article XXIV – Zoning Board of Appeals, the Village Zoning Board of Appeals may waive any of the provisions stated in this Article when after a request for such a variance has been made and reviewed, the Village Zoning Board of Appeals determines that such variance is necessary for the lighting application.
- b. Requests for such a Variance shall be made to the Village Zoning Board of Appeals in such form as the Planning Commission shall prescribe and shall include, but not be limited to:
 1. A description of the lighting plan; and
 2. A description of the efforts that have been made to comply with the provisions of these regulations and the reasons such an exception is necessary.
- c. In reviewing a request for such variance, the Village Zoning Board of Appeals shall consider safety design, and other factors deemed appropriate by the Village Planning Commission and shall consider the following:
 1. The new or replacement Luminaries is Fully Shielded Luminaries when the rated output of the Luminaries is greater than one thousand, eight-hundred (1,800) Lumens.
 2. If a lighting recommendation or regulation applies, the minimum/maximum illuminance specified by the recommendations or regulation is used.
 3. If no lighting recommendation or regulation applies, the minimum illuminance adequate for the intended purpose is used, giving full consideration to safety, energy conservation, glare, and minimizing light trespass.
 4. For Roadway Lighting, a determination is made that the purpose of the lighting installation or replacement cannot be achieved by installation of reflectorized roadway markers, lines, warnings or informational signs, or other passive means.
 5. Adequate consideration has been given to conserving energy and minimizing Glare, Light Pollution, and Light Trespass.
- d. Exemptions from the provisions of this section are permitted only when:
 1. Federal or State Laws, rules and regulations take precedence over these provisions.
 2. Fire, police, rescue, or repair personnel need light for temporary emergency situation.
 3. There are special requirements, such as sports facilities and monument or flag lighting; all such lighting shall be selected and installed to shield the Lamp(s)

from direct view to the greatest extent possible, and to minimize upward lighting and Light Trespass.

4. A determination has been made by the Village Zoning Board of Appeals that there is a compelling safety interest that cannot be addressed by any other method.

Section 20.13 – Applicability

- a. Whenever a person is required to obtain a building or electrical permit for Outdoor Lighting or Signage, a Conditional Use Permit, subdivision or condominium approval or any Development Plan Approval by the Village, including all Village projects, or whenever a person requests rezoning, the applicant shall, as a part of said application, submit sufficient information to enable the Building Official to determine whether the proposed lighting will comply with this Article. All applications may be subject to review and action by the Planning Commission at the discretion of the Building Official or the Planning Commission.
- b. All building additions or modifications of twenty-five (25%) percent or more in terms of additional dwelling units, gross floor area, or parking spaces, either with a single addition or with cumulative additions subsequent to the effective date of this provision, shall invoke the requirements of this Article for the entire property, including previously installed and any new outdoor lighting. Cumulative modification or replacement of outdoor lighting constituting twenty-five (25%) percent or more of the permitted lumens for the parcel, no matter the actual amount of lighting already on a non-conforming site, shall constitute a major addition for the purposes of this section.
- c. Additions or modifications of less than twenty-five (25%) percent to existing uses, as described above, and that require a permit, shall require the submission of a complete inventory and site plan detailing all existing and any proposed new outdoor lighting. Any new lighting on the site shall meet the requirements of this Article with regard to shielding and lamp type; the total outdoor light output after the modifications are complete shall not exceed that on the site before the modification, or that permitted by this Article, whichever is larger.
- d. If a property or use with non-conforming lighting is abandoned as defined in this Article, then all outdoor lighting shall be reviewed and brought into compliance with this Article before the use is resumed.
- e. All applications, except those for single family residences, shall include the following:
 1. Site plan indicating both the proposed location and any already existing on the site of all outdoor lighting fixtures; and
 2. A description of each illuminating device, fixture, lamp, support and shield. This description may include, but is not limited to, manufacturers' catalog cuts and drawings (including sections where required), lamp types and lumen outputs; and

3. Photometric data, such as that furnished by manufacturers, or similar showing the angle of cut off of light emissions; and
 4. Such other information as the Building Official or Planning Commission may determine is necessary to ensure compliance with this Article.
- f. If any subdivision or condominium proposes to have installed street or other common or public area outdoor lighting, submission of the information in Subsection (e) above, shall be required for all such lighting.
 - g. If the Building Official determines that the proposed lighting does not comply with this Article, the permit shall not be issued or the plan approved.
 - h. Lighting for Public Roadways is exempt from the provisions of this Article.

ARTICLE XXI
WIRELESS TELECOMMUNICATION TOWERS
AND ANTENNAS

Section 21.01 – Purpose

The purpose of this Article is to establish general guidelines for the siting of wireless communications towers and antennas. The goals of this Article are to:

- a. Protect residential areas and land uses from potential adverse impacts of towers and antennas.
- b. Encourage the location of towers in non-residential areas.
- c. Minimize the total number of towers throughout the community.
- d. Strongly encourage the joint use of new and existing tower sites as a primary option rather than construction of additional single-use towers.
- e. Encourage users of towers and antennas to locate them, to the extent possible, in areas where the adverse impact on the community is minimal.
- f. Encourage users of towers and antennas to configure them in a way that minimizes the adverse visual impact of the towers and antennas through careful design, siting, landscape screening, and innovative camouflaging techniques.
- g. Enhance the ability of the providers of telecommunications services to provide such services to the community quickly, effectively, and efficiently.
- h. Consider the effect of communication towers on the public health and safety.
- i. Avoid potential damage to adjacent properties from tower failure through engineering and careful siting of tower structures. In furtherance of these goals, the Village of Leonard shall give due consideration to the Village’s master plan, zoning map, existing land uses, and environmentally sensitive areas in approving sites for the location of towers and antennas.

Section 21.02 – Definitions

- a. **Alternative Tower Structure:** Means man-made trees, clock towers, bell steeples, light poles, and similar alternative-design mounting structures that camouflage or conceal the presence of antennas or towers.
- b. **Antenna:** Means any exterior transmitting or receiving device mounted on a tower, building or structure and used in communications that radiate or capture electromagnetic

waves, digital signals, analog signals, radio frequencies (excluding radar signals), wireless telecommunications signals or other communication signals.

- c. **Backhaul Network:** Means the lines that connect a provider's towers/cell sites to one or more switching offices, networks, and/or service providers.
- d. **FAA:** Means the Federal Aviation Administration.
- e. **FCC:** Means the Federal Communications Commission.
- f. **Height:** Means, when referring to a tower or other structure, the distance measured from the finished grade of the parcel to the highest point on the tower or other structure, including the base pad and any antenna.
- g. **Preexisting Towers and Preexisting Antennas:** Means any tower or antenna for which a Building Permit or Special Use Permit has been properly issued prior to the effective date of this Ordinance, including permitted towers or antennas that have not yet been constructed so long as such approval is current and not expired, or any tower or antenna existing prior to the effective date of this Ordinance for which a Building Permit or Special Use Permit was not required at the time of construction or installation thereof.
- h. **Tower:** Means any structure that is designed and constructed primarily for the purpose of supporting one or more antennas for telephone, radio and similar communication purposes, including self-supporting lattice towers, guyed towers, or monopole towers. The term includes radio and television transmission towers, microwave towers, common-carrier towers, cellular telephone towers, wireless internet towers, alternative tower structures, and the like. The term includes the structure and any support thereto.
- i. **Pre-existing Structure:** Means any tall structure whose primary function is not for wireless communications.

Section 21.03 – Applicability

- a. **New Towers and Antennas.** All new towers or antennas in the Village of Leonard shall be subject to these regulations, except as provided in Sections 21.03(b) through 21.03(d), inclusive.
- b. **Amateur Radio Station Operators/Receive Only Antennas.** This Ordinance shall not govern any tower, or the installation of any antenna, that is under seventy (70) feet in height and is owned and operated by a federally-licensed amateur radio station operator or is used exclusively for receive only antennas.
- c. **Preexisting Towers or Antennas.** Preexisting towers and preexisting antennas shall not be required to meet the requirements of this Ordinance, other than the requirements of Sections 21.06(f) and (g).

d. **Exempt Wireless Communication Equipment.**

1. Wireless Communication Equipment is deemed a permitted use if all of the following conditions are met:
 - (a) The equipment is proposed to be collocated on an existing support structure or compound.
 - (b) The existing structure or compound is in compliance with the Village Zoning Ordinance or was approved by the Village.
 - (c) The proposed location would not do any of the following:
 - (1) Increase the overall height by more than twenty (20) feet or 10% of originally approved height, whichever is greater.
 - (2) Increase the width of the structure by more than the minimum necessary to permit co-locations.
 - (3) Increase the area of the existing compound to greater than 2,500 square feet.
 - (d) The proposed collocation complies with the terms and conditions of any previous final approval of the support structure or compound.
2. If the proposed collocation fails to meet all four (4) requirements, it is subject to the Special Land Use Approval Process in accordance with Section 21.09.

Section 21.04 – Essential Services

Essential Services authorized and regulated by Federal, State or Local law shall generally be exempt from the application of this Ordinance, except that:

- a. All telecommunication towers, antenna and related structures and equipment are subject to the terms of Article XXI - Wireless Telecommunications, Towers and Antennas of this Ordinance, and
- b. All other above grade buildings are subject to Site Plan Review in accordance with Article XXV - Site Plan Review of this Ordinance

Section 21.05 – Reserved

Section 21.06 – General Requirements

- a. **Principal or Accessory Use.** Antennas and towers may be considered either principal use, special land use, or accessory use. A different existing use of an existing structure on the same lot shall not preclude the installation of an antenna or tower on such lot.

- b. **Lot Size.** For purposes of determining whether the installation of a tower or antenna complies with district development regulations, including but not limited to setback requirements, lot-coverage requirements, and other such requirements, the dimensions of the entire lot shall control, even though the antennas or towers may be located on leased parcels within such lot.
- c. **Inventory of Existing Sites.** Each applicant for an antenna and/or tower shall provide to the Building Official an inventory of its existing towers, antennas, or sites approved for towers or antennas, that are either within the jurisdiction of the Village of Leonard or within one mile of the border thereof, including specific information about the location, height, and design of each tower. The Building Official may share such information with other applicants applying for administrative approvals or special use permits under this Ordinance or other organizations seeking to locate antennas within the jurisdiction of the Village of Leonard, provided, however that the Building Official is not, by sharing such information, in any way representing or warranting that such sites are available or suitable.
- d. **Aesthetics.** Towers and antennas shall meet the following requirements:
1. Towers shall either maintain a galvanized steel finish or, subject to any applicable standards of the FAA, be painted a neutral color so as to reduce visual obtrusiveness.
 2. At a tower site, the design of the buildings and related structures shall, to the extent possible, use materials, colors, textures, screening, and landscaping that will blend them into the natural setting and surrounding buildings.
 3. If an antenna is installed on a structure other than a tower, the antenna and supporting electrical and mechanical equipment must be of a neutral color that is identical to, or closely compatible with, the color of the supporting structure so as to make the antenna and related equipment as visually unobtrusive as possible
 4. New towers and antennas governed by this Ordinance, in excess of seventy (70) feet shall be of a monopole construction (no lattice).
- e. **Lighting.** Towers shall not be artificially lighted, unless required by the FAA or other applicable authority. If lighting is required, the lighting alternatives and design chosen must cause the least disturbance to the surrounding views.
- f. **State or Federal Requirements.** All towers must meet or exceed current standards and regulations of the FAA, the FCC, and any other agency of the State or Federal government with the authority to regulate towers and antennas. If such standards and regulations are changed, then the owners of the towers and antennas governed by this Ordinance shall bring such towers and antennas into compliance with such revised standards and regulations within six (6) months of the effective date of such standards and regulations, unless a different compliance schedule is mandated by the controlling State or Federal agency. Failure to bring towers and antennas into compliance with such

revised standards and regulations shall constitute grounds for the removal of the tower or antenna at the owner's expense.

- g. **Building Codes; Safety Standards.** To ensure the structural integrity of towers, the owner of a tower shall ensure that it is maintained in compliance with standards contained in applicable state or local building codes and the applicable standards for towers that are published by the Electronic Industries Association, as amended from time to time. If, upon inspection, the Village of Leonard concludes that a tower fails to comply with such codes and standards and constitutes a danger to persons or property, then upon notice being provided to the owner of the tower, the owner shall have thirty (30) days to bring such tower into compliance with such standards. Failure to bring such tower into compliance within said thirty (30) days shall constitute grounds for the removal of the tower or antenna at the owner's expense.
- h. **Measurement.** For purposes of measurement, tower setbacks and separation distances shall be calculated and applied to facilities located in the Village of Leonard irrespective of municipal and county jurisdictional boundaries.
- i. **Non- Essential Services.** Towers and antennas shall be regulated and permitted pursuant to this Ordinance and shall not be regulated or permitted as essential services, public utilities, or private utilities.
- j. **Franchises.** Owners and/or operators of towers or antennas shall certify that all franchises required by law for the construction and/or operation of a wireless communication system in Village of Leonard have been obtained and shall file a copy of all required franchises with the Building Official.
- k. **Signs.** No signs (except essential safety and maintenance signs) shall be allowed on an antenna, tower or fencing (unless approved as part of Site Plan Review).
- l. **Buildings and Support Equipment.** Buildings and support equipment associated with antennas or towers shall comply with the requirements of this Article.
- m. **Multiple Antenna/Tower Plan.** The Village of Leonard encourages the users of towers and antennas to submit a single application for approval of multiple towers and/or antenna sites. Applications for approval of multiple sites shall be given priority in the review process.

Section 21.07 – Cable Micro Cell Networks

Cable microcell network through the use of multiple low-powered transmitter/receivers attached to existing wire-line systems, such as conventional cable or telephone wires, or similar technology that does not require the use of towers are not subject to a special use permit approval.

Section 21.08 – Administratively Approved Uses

- a. **General.** The following provisions shall govern the issuance of administrative approvals for towers and antennas.
 1. The Planning Commission may administratively approve the uses listed in this Section.
 2. Each applicant for administrative approval shall apply to the Planning Commission, through the Clerk’s Office, providing the information set forth in Sections (21.09(b)(1) and 21.09(b)(3) of this Article and a nonrefundable fee as established by Resolution of the Village of Leonard to reimburse the Village of Leonard for the costs of reviewing the application.
 3. The Planning Commission shall review the application for administrative approval and determine if the proposed use complies with this Ordinance.
 4. The Planning Commission shall respond to each such application within sixty (60) days after receiving it by either approving or denying the application. If the Planning Commission fails to respond to the applicant within said sixty (60) days, then the application shall be deemed to be approved.
 5. In connection with any such administrative approval, the Planning Commission may, in order to encourage shared use, administratively reduce any Zoning District setback requirements by up to fifty (50%) percent.
 6. In connection with any such administrative approval, the Planning Commission may, in order to encourage the use of monopoles, administratively allow the reconstruction of an existing tower to monopole construction.
 7. If an administrative approval is denied, the applicant shall file an application for a special approval pursuant to Section 21.09 prior to filing any appeal that may be available under the Zoning Ordinance.
- b. **List of Administratively Approved Uses.** The following uses may be approved by the Planning Commission after conducting an administrative review:
 1. Locating antennas on existing structures or towers consistent with the terms of subsections (a) and (b) below.
 - (a) **Antennas on existing structures.** Any antenna which is not attached to a tower may be approved by the Planning Commission as an accessory use to any commercial, industrial, professional, institutional, or multi-family structure of eight or more dwelling units, provided:
 - (4) The antenna does not extend more than thirty (30) feet above the highest point of the structure.

- (5) The antenna complies with all applicable FCC and FAA regulations; and
 - (6) The antenna complies with all applicable building codes.
- (b) **Antennas on existing towers.** An antenna which is attached to an existing tower may be approved by the Planning Commission and, to minimize adverse visual impacts associated with the proliferation and clustering of towers, collocation of antennas by more than one carrier on existing towers shall take precedence over the construction of new towers, provided such collocation is accomplished in a manner consistent with the following:
- (1) A tower which is modified or reconstructed to accommodate the collocation of an additional antenna shall be of the same tower type as the existing tower, unless the Planning Commission allows reconstruction as a monopole.
 - (2) **Height**
 - (a) A preexisting tower may be modified or rebuilt to a taller height, not to exceed thirty (30) feet over the tower's existing height, to accommodate the collocation of an additional antenna.
 - (b) The height change referred to in subsection (2) (a), may only occur one time per Communication Tower.
 - (3) **Onsite location**
 - (a) A tower which is being rebuilt to accommodate the collocation of an additional antenna may be moved onsite within fifty (50) feet of its existing location.
 - (b) After the tower is rebuilt to accommodate collocation, only one (1) tower may remain on the site.
2. Installing a cable micro cell network through the use of multiple low-powered transmitters/receivers attached to existing wire line systems, such as conventional cable or telephone wires, or similar technology that does not require the use of towers.

Section 21.09 – Special Approvals

- a. General. Those uses not otherwise exempt or deemed an administratively approved use require Special Approval. The following provisions shall govern the issuance of special approvals for towers or antennas:

1. Except applications in accordance with Section 21.03(d)(1)(d), applications for special approvals under this Section shall be subject to the procedures and requirements of Article XXV - Site Plan Review and Article XXVI - Special Approval Procedures and Standards of the Zoning Ordinance, except as modified by this Section.
2. Applications for Special Approval pursuant to Section 31.03(d)(2) shall be reviewed within fourteen (14) days from receipt to determine whether the application is administratively complete. The application is automatically considered administratively complete if the Village fails to make a determination within fourteen (14) days. The municipality has an additional sixty (60) or ninety (90) days (depending on the type of equipment collocation or support structure) to approve or deny the application. If the Village fails to act within the prescribed time, the application is deemed automatically approved. Conditions on approval are limited to local ordinances, and state and federal laws.
3. In recommending Special Approval, the Planning Commission may impose conditions to the extent the Planning Commission concludes such conditions are necessary to minimize any adverse effect of the proposed tower on adjoining properties.
4. Any information of an engineering nature that the applicant submits, whether civil, mechanical, or electrical, shall be certified by a licensed professional engineer.
5. An applicant for a Special Approval shall submit the information described in this Section and a non-refundable fee as established by Resolution of the Village of Leonard to reimburse the Village of Leonard for the costs of reviewing the application.

b. Towers.

1. **Information required.** In addition to any information required for applications for special approvals pursuant to Article XXVI - Special Approval Procedures and Standards of the Zoning Ordinance, applicants for Special Approval for a tower shall also submit the following information:
 - (a) A scaled site plan clearly indicating the location, type and height of the proposed tower (including height and locations for future carriers), on-site land uses and zoning, adjacent land uses and zoning (including when adjacent to other municipalities), Master Plan classification of the site, adjacent roadways, proposed means of access, setbacks from property lines, elevation drawings of the proposed tower (including location of future carriers) and any other structures (including locations for future carrier equipment shelters), topography, parking, and other information deemed by the Building Official to be necessary to assess compliance with this Ordinance.

- (b) Legal description of the parent tract and leased parcel (if applicable).
- (c) The setback distance between the proposed tower and the nearest residential unit, and residentially zoned properties.
- (d) An updated site plan or map showing the separation distance from other towers described in the inventory of existing sites submitted pursuant to Section 21.06(c). The applicant shall also identify the type of construction of the existing tower(s) and the owner/operator of the existing tower(s), if known.
- (e) A landscape plan showing specific landscape materials.
- (f) The method of fencing, and finished color and, if applicable, the method of camouflage and illumination.
- (g) A description of compliance with Sections 21.06(c), (d), (e), (f), (g), (j), (l), (m), and 21.09(b)(4), 21.09(b)(5), and all applicable Federal, State or local laws.
- (h) A notarized statement by the applicant as to whether construction of the tower will accommodate collocation of additional antennas for future users.
- (i) Identification of the entities providing the backhaul network for the tower(s) described in the application and other towers and antennas owned or operated by the applicant in the Village of Leonard.
- (j) A description of the suitability of the use of existing towers, other structures or alternative technology not requiring the use of towers or structures to provide the services to be provided through the use of the proposed new tower.
- (k) A description of the feasible location(s) of future towers or antennas within the Village of Leonard based upon existing physical, engineering, technological, or geographical limitations in the event the proposed tower is erected.

2. **Factors Considered in Recommending Special Approvals for Towers.** In addition to any standards for consideration of special approval permit applications pursuant to Article XXVI - Special Approval of the Zoning Ordinance, the Planning Commission shall consider the following factors in determining whether to recommend Special Approval, although the Planning Commission may waive or reduce the burden on the applicant of one or more of these criteria if the Planning Commission concludes that the goals of this Ordinance are better served thereby:

- (a) Height of the proposed tower; and

- (b) Proximity of the tower to residential structures, residential district boundaries, commercial buildings and public buildings; and
- (c) Nature of adjacent and nearby land uses; and
- (d) Surrounding topography; and
- (e) Surrounding tree coverage and foliage; and
- (f) Design of the tower, with particular reference to design characteristics that have the effect of reducing or eliminating visual obtrusiveness; and
- (g) Proposed ingress and egress; and
- (h) Availability of suitable existing towers, other structures, or alternative technologies not requiring the use of towers or structures, as discussed in Section 21.09(b).

3. **Availability of Suitable Existing Towers, Other Structures, or Alternative Technology.** No new tower shall be permitted unless the applicant demonstrates to the reasonable satisfaction of the Planning Commission that no existing tower, structure, or alternative technology that does not require the use of towers or structures can accommodate the applicant's proposed antenna. An applicant shall submit information requested by the Planning Commission related to the availability of suitable existing towers, other structures or alternative technology. Evidence submitted to demonstrate that no existing tower, structure, or alternative technology can accommodate the applicant's proposed antenna may consist of any of the following:

- (a) No existing towers or structures are located within the geographic area which meets applicant's engineering requirements.
- (b) Existing towers or structures are not of sufficient height to meet applicant's engineering requirements.
- (c) Existing towers or structures do not have sufficient structural strength to support applicant's proposed antenna and related equipment.
- (d) The applicant's proposed antenna would cause electromagnetic interference with the antenna on the existing towers or structures, or the antenna on the existing towers or structures would cause interference with the applicant's proposed antenna.
- (e) The fees, costs, or contractual provisions required by the owner in order to share an existing tower or structure or to adapt an existing tower or structure for sharing are unreasonable. Costs exceeding new tower development are presumed to be unreasonable.

- (f) The applicant demonstrates that there are other limiting factors that render existing towers and structures unsuitable.
 - (g) The applicant demonstrates that an alternative technology that does not require the use of towers or structures, such as a cable micro cell network using multiple low-powered transmitters/receivers attached to a wire line system, is unsuitable. Costs of alternative technology that exceed new tower or antenna development shall not be presumed to render the technology unsuitable.
4. **Setbacks.** The following setback requirements shall apply to all towers for which special approval is required:
- (a) Towers must be set back a distance equal to the height of the tower from any adjoining lot line in the case of monopole construction. Guyed or lattice towers shall be setback one and one-half (1½) times the tower height from any adjoining lot line. Setbacks for all towers shall be one and one-half (1½) times the tower height from the nearest edge of any public road right-of-way or road easement.
 - (b) Guys and accessory buildings must satisfy the minimum setback requirements for any building in the applicable zoning district.
5. **Security fencing.** Towers, supporting cables and guy wire anchors shall be enclosed by security fencing not less than six (6) feet in height and shall also be equipped with an appropriate anti-climbing device; provided, however, that the Planning Commission may waive such requirements, as it deems appropriate.
6. **Landscaping.** The following requirements shall govern the landscaping surrounding towers for which a special use permit is required; provided, however, that the Planning Commission may waive such requirements if the goals of this Ordinance would be better served thereby.
- (a) Tower facilities shall be landscaped with a buffer of plant materials that effectively screens the view of the tower compound from property used for residences. The standard buffer shall consist of a landscaped strip at least four (4) feet wide outside the perimeter of the compound.
 - (b) In locations where the visual impact of the tower would be minimal, the landscaping requirement may be reduced or waived.
 - (c) Existing mature tree growth and natural land forms on the site shall be preserved to the maximum extent possible. In some cases, such as towers sited on large, wooded lots, natural growth around the property perimeter may be sufficient buffer.

Section 21.10 – Reserved

Section 21.11 – Buildings or Other Equipment Storage

- a. **Antennas Mounted on Pre-existing Structures or Rooftops.** The equipment cabinet or structure used in association with antennas shall comply with the following:
1. The cabinet or structure shall not contain more than twenty (20) square feet of gross floor area or be more than four (4) feet in height. A cabinet or structure over twenty (20) square feet of gross floor area or four (4) feet in height shall be located on the ground and shall not be located on the roof of a building or structure.
 2. If the equipment structure is located on the roof of a building, the area of the equipment structure and other equipment and structures shall not occupy more than twenty (20%) percent of the roof area.
 3. Equipment storage buildings or cabinets shall comply with all applicable building codes.
 - (a) **Antennas Mounted on the Ground.** The equipment cabinet or structure used in association with antennas shall be screened with a solid fence six (6) feet in height or an evergreen hedge with an ultimate height of a least eight (8) feet and a planted height of at least three (3) feet. Only safety and maintenance signs may be located on any fence associated with the antennas.

Section 21.12 – Removal of Abandoned Antennas and Towers

Any antenna or tower that for a continuous period of twelve (12) months is not operated shall be considered abandoned, and the owner of such antenna or tower shall remove the same within ninety (90) days of receipt of notice from the Village of Leonard notifying the owner of such abandonment. Failure to remove an abandoned antenna or tower within said ninety (90) days shall be grounds to remove the tower or antenna at the owner's expense. If there are two (2) or more users of a single tower, then this provision shall not become effective until all users cease using the tower.

Section 21.13 – Nonconforming Uses

- a. **Not Expansion of Nonconforming Use.** Towers that are constructed, and antennas that are installed, in accordance with the provisions of this Ordinance shall not be deemed to constitute the expansion of a nonconforming use or structure.
- b. **Preexisting towers.** Preexisting towers shall be allowed to continue their usage as they presently exist. Routine maintenance (including replacement with a new tower of like construction and height) shall be permitted on such preexisting towers. New construction

other than routine maintenance on a preexisting tower shall comply with the requirements of this Ordinance.

- c. **Rebuilding Damaged or Destroyed Nonconforming Towers or Antennas.** Notwithstanding Section 21.12, bona fide nonconforming towers or antennas that are damaged or destroyed may be rebuilt without having to first obtain Administrative Approval or Special Approval. The type, height, and location of the tower onsite shall be of the same type, height, and location as the damaged or destroyed tower. Building permits to rebuild the tower and related structures shall comply with the then applicable building codes and shall be obtained within one-hundred and eighty (180) days from the date the tower or structure is damaged or destroyed. If no permit is obtained or if said permit expires, the tower or antenna shall be deemed abandoned as specified in Section 21.12.

ARTICLE XXII

ADMINISTRATION AND ENFORCEMENT

Section 22.01 – Enforcement

The provisions of this Ordinance shall be administrated and enforced by the Building Official or any other employees, inspectors, and officials as the Village Council may designate to enforce the provisions of the Ordinance. The Village Clerk’s office shall serve as the Building Department for the Village.

Section 22.02 – Duties of Building Department

- a. The Building Official shall have the power to grant Building Permits and Certificates of Occupancy, to make inspections of buildings or premises necessary to carry out his duties in the enforcement of this Ordinance.
- b. It shall be unlawful for the Building Official to approve any plans or issue any permits or Certificates of Occupancy for any excavation, construction, and alteration, change in type of use, or change in type of occupancy until such plans have been inspected in detail and found to conform to this Ordinance.
- c. The Building Official shall require that all applications for Building Permits be accompanied by plans, written statements, and specifications including a plot plan in duplicate, which shall agree with the Site Plan approved by the Planning Commission, when required under Article XXV - Site Plan Review of this Ordinance. The plot plan shall be prepared at a scale of not less than one (1) inch equals thirty (30) feet, and shall show the following in sufficient detail to enable the Building Official to ascertain whether the proposal is in conformance with this Ordinance.
 1. The legal description, actual shape, location, and dimensions of the lot and the lines of the lots or parcels under separate ownership contained therein.
 2. The shape, size, and location of all buildings or other structures to be erected, altered, or moved, and of any buildings or other structures already on the lot.
 3. The existing and intended use of the lot and of all such structures upon it, including, in residential areas, the number of dwelling units the building is intended to accommodate.
 4. The width and alignment of all abutting streets, alleys, easements of access and public open space.
 5. In the case of an application for other than a residence, the applicant shall also furnish a sworn statement stating all uses to which he proposes to put the property or any proposed building on the property.

6. Existing and proposed grades to an extent necessary to allow the Building Official to properly determine the results of the proposed works.
 7. Such other information concerning the lot or adjoining lots as may be essential for determining whether the provisions of this Ordinance are being observed.
- d. If the proposed excavation, construction, moving, alteration, or use of land as set forth in the application is in conformity with the provisions of this Ordinance, the Building Official shall issue a building permit within ten (10) days after the receipt of such application. If any application for such permit is not approved, the Building Official shall state in writing on the application the cause for such disapproval. Issuance of a permit shall in no case be construed as waiving any provisions of this Ordinance. A record of all such applications shall be kept on file in the office of the Village Clerk.
 - e. One (1) copy of all Building Permits shall be conspicuously posted on the premises.
 - f. Upon the completion of the work authorized by a building permit, the holder thereof shall seek final inspection thereof by notifying the Building Official who shall then cause such final inspection to be made promptly.
 - g. Whenever an application for a Building Permit indicates the necessity for constructing an on-site sewage disposal system and/or water well system on the premises, the Building Official shall not issue such permit unless the Oakland County Health Division shall have approved the site for the construction of such facilities.
 - h. The Building Official shall not refuse to issue a permit when conditions imposed by this Ordinance are met by the applicant despite violations of contracts, such as covenants or private agreements, which may occur upon the granting of such permit.
 - i. The Building Official is under no circumstance permitted to make changes to this Ordinance or to grant exceptions to the meaning of any clause, order, or regulation contained in this Ordinance.

Section 22.03 – Building Permits

The following shall apply in the issuance of any permit:

- a. **Permits Required:** It shall be unlawful for any person to commence excavation for, construction of any building or structure, structural changes, or repairs in any existing building or structure, or moving of an existing building, without first obtaining a Building Permit from the Village Clerk. No permit shall be issued for construction, alteration or remodeling of any building or structure until an application has been submitted in accordance with the provisions of this Ordinance showing that the construction proposed is in compliance with the provisions of this Ordinance, with the Building Code, and with other applicable codes and ordinances.

No plumbing, electrical, drainage, or other permit shall be issued until the Clerk has determined that the plans and designated use indicates that the structure and premises, if constructed as planned and proposed, will conform to the provisions of this Ordinance.

“Alteration” or “repair” of an existing building or structure, shall include any changes in structural members, stairways, basic construction type, kind or class of occupancy, light, means of egress and ingress, or any other changes affecting or regulated by the Building Code, the Housing Law of the State of Michigan, or this Ordinance, except for minor repairs or changes not involving any of the aforesaid provisions.

- b. **Permits for New Use of Land:** A Building Permit shall also be obtained for the new use of land, whether the land is presently vacant or a change in land use is proposed. A site plan shall be complete for each proposed land use subject to the requirements of Article XXV - Site Plan Review.
- c. **Permits for New Use of Buildings or Structures:** A Building Permit shall also be obtained for any change in use of an existing building or structure to a different class or type of use. A site plan shall be completed for each proposed land use subject to the requirements of Article XXV - Site Plan Review.
- d. **Accessory Buildings:** Accessory buildings when erected at the same time as the principal building on a lot and shown on the application thereof shall not require a separate Building permit, provided the accessory building is built in conformance to this Ordinance.
- e. All Building Permits, when issued, shall be valid for a period of one (1) year only, but may be extended for a further period of not to exceed one (1) year, if the Village Clerk shall find good cause shown for failure to complete work for which said permit was issued; provided that the exterior of any such structure must be completed within one (1) year from the date of the original issuance of a Building Permit.
- f. Should the holder of a Building Permit fail to complete the work for which said permit was issued within the time limit as set forth above, any unfinished structure is hereby declared a nuisance, per se and the same may be abated by appropriate action before the Circuit Court of the County. The Board of Zoning Appeals, the Village Council, or any aggrieved person may institute a suit to have the nuisance abated.

Section 22.04 – Certificate of Occupancy

It shall be unlawful to use or permit the use of any land, building, or structure for which a Building Permit is required, and to use or permit to be used any building or structure hereafter altered, extended, erected, repaired, or moved, until the Building Official shall have issued a Certificate of Occupancy stating that the provisions of this Ordinance have been complied with. The following provisions shall apply:

- a. **Record of Certificates:** A record of all Certificates of Occupancy shall be kept in the office of the Village Clerk and copies of such Certificates of Occupancy shall be

furnished upon request to a person or persons having a proprietary or tenancy interest in the property involved.

- b. **Certificates of Accessory Buildings to Dwellings:** Accessory buildings or structures to a dwelling shall not require a separate Certificate of Occupancy, but rather, may be included in the Certificate of Occupancy for the principal of dwelling, building, or structure on the same lot when such accessory buildings or structures are completed at the same time as the principal use.
- c. **Certificate Validity:** The Certificate of Occupancy as required for new construction of, or renovations to existing buildings and structures, in the Building Code, shall also constitute a Certificate of Occupancy as required by this Ordinance.
- d. **Certificates for Existing Non-Residential Buildings:** Certificates of Occupancy shall be issued for existing non-residential buildings, structures or parts thereof, or existing uses of land if after inspection it is found that such buildings, structures or parts thereof, or such use of land, are in conformity with the provisions of this Ordinance.
- e. **Temporary Certificates:** Certificates of Temporary Occupancy may be issued for a part of a building or structure prior to the occupation of the entire building or structure, provided that such Certificate of Temporary Occupancy shall not remain in force more than six (6) months, or more than five (5) days after the building or structure is fully completed and ready for occupancy, and provided further that such portions of the building or structure are in conformity with the provisions of this Ordinance.
- f. **Application for Certificates of Occupancy:** Any person applying for a Building Permit shall at the same time apply to the Village in writing for a Certificate of Occupancy. It shall be the duty of such person to notify the Building Official upon completion of the building or structure. The Building Official shall, within ten (10) business days after actual receipt of such notification, inspect such building or structure, or part thereof, or the proposed use of the premises, and if it is in conformity with this and other applicable ordinances and laws, the Building Official shall forthwith issue a Certificate of Occupancy therefore. If the Building Official shall determine that a violation exists, he shall not issue a Certificate of Occupancy and shall forthwith notify the applicant of such refusal and the cause therefore.

Section 22.05 – Fees

Fees for inspections and the issuance of Permits or Certificates or copies thereof required or issued under the provisions of this Ordinance shall be collected by the Village in advance of the issuance of such permits or certificates. The amount of such fees shall be established by the Village Council from time to time, and shall cover the cost of inspection and supervision resulting from the enforcement of this Ordinance.

Section 22.06 – Tickets

The Building Official shall issue appearance tickets for violations of this Ordinance.

Section 22.07 – Reserved

Section 22.08 – Procedure of Notice

- a. The Notice shall be published in a newspaper of general circulation within the Village not less than fifteen (15) days prior to the scheduled hearing date.
- b. The Notice shall also be sent by mail or personal delivery to the owners of the property that is the subject of the request, to all person to whom real property is assessed within three-hundred (300) feet of the property that is the subject of a request, and to the occupants of all structures within three-hundred (300) feet of the subject property, regardless of whether the property or structure is located within the Village. If the name of the occupant is not known, the term “occupant” may be used for the intended recipient of the notice. Notification need not be given to more than one (1) occupant of a structure, except that if a structure contains more than one (1) dwelling unit or spatial area owned or leased by different persons, partnerships, businesses, or organizations, one(1) occupant of each unit or spatial area shall be given notice. In the case of a single structure containing more than four (4) dwelling units or other distinct spatial areas owned or leased by different persons, notice may be given to the manager or owner of the structure, who shall be requested to post the notice at the primary entrance to the structure. The Notice is considered to be given when personally delivered or when deposited for delivery with the United States Postal Service. Notices under this Section shall be given not less than fifteen (15) days prior to the date of the scheduled hearing date.
- c. The Notice Shall:
 1. Describe the nature of the request; and
 2. Provide a description of the property that is the subject of the request, including a listing of all existing street addresses within the property. If there are no street addresses, other means of identification may be used; and
 3. State when and where the request will be considered; and
 4. Indicate when and where written comments will be received concerning the request.

ARTICLE XXIII

PLANNING COMMISSION

Section 23.01 – Creation of Planning Commission:

The Village of Leonard Planning Commission is hereby designated as the Zoning Commission specified in Section 301 of Michigan Public Act 110 of the Public Acts of 2006, as amended, and shall perform the duties of said Commission as provided by statute, in connection with administration and enforcement of and amendments to this Ordinance.

Section 23.02 – Membership of the Planning Commission:

The Planning Commission shall consist of not fewer than five (5) or more than nine (9) members appointed by the Village. The members shall be selected upon the basis of the members' qualifications and fitness to serve as members of the Planning Commission. Members shall be qualified electors of the Village, except that two (2) members may be individuals who are not qualified electors of the Village. Upon expiration of the terms of the members of the Planning Commission, or in the event of a vacancy, successors shall be appointed in like manner for terms of three (3) years each.

A member of the Planning Commission shall serve until a successor is appointed and has been qualified. The Chief Administrative Official or a person designated by the Chief Administrative Official, if any, the Village President, one (1) or more Village Council Members, or any combination thereof, may be appointed to the Planning Commission, as ex officio members. However, not more than one-third (1/3) of the members of the Planning Commission may be ex officio members. Except as provided in this Section, an elected officer or an employee of the Village is not eligible to be a member of the Planning Commission. The term of an ex officio member shall correspond to his or her term on the Village Council, or in the case of a Chief Administrative Official with the term of the President that appointed him or her.

Section 23.03 – Officers of the Planning Commission:

The Planning Commission shall elect from its members a Chairperson, a Recording Secretary, and other officers or establish such committees it considers necessary and may engage any employees, including for technical assistance, it requires. Beginning September 1, 2008, an ex officio member of the Planning Commission is not eligible to serve as Chairperson.

Section 23.04 – Removal of Planning Commission Members:

The Village Council shall provide for the removal of a member of the Planning Commission for misfeasance, malfeasance, or nonfeasance in office upon written charges and after Public Hearing.

Section 23.05 – Meetings of the Planning Commission:

The Planning Commission shall hold a minimum of four (4) Regular Meetings annually, giving notice of the time and place by publication in a newspaper of general circulation in the Village. Notice shall be given not less than fifteen (15) days before meeting. The Planning Commission shall submit a report at least once a year to the Village Council on the administration and enforcement of this Ordinance and on recommendations for amendments or supplements to this Ordinance.

Section 23.06 – Bylaws:

The Planning Commission shall adopt Bylaws for the transaction of business, and shall keep a public record of its resolutions, transactions, findings, and determinations.

ARTICLE XXIV
ZONING BOARD OF APPEALS

Section 24.01 – Creation

There is hereby established a Zoning Board of Appeals, hereinafter called the “Board”, which shall perform its duties and exercise its powers as provided in Michigan Public Act 110 of the Public Acts of 2006, as amended, and in such a way that the objectives of this Ordinance shall be observed, public safety secured and welfare secured, and substantial justice done.

Section 24.02 – Membership of the Zoning Board of Appeals

It is hereby established that the Village Council shall act as a Zoning Board of Appeals, pursuant to MCL 125.3601(2) (Michigan Zoning Enabling Act-MZEA), which shall be composed of seven (7) members.

The term of each member shall be limited to the time they are members of Village Council. The Chairperson, Vice Chairperson, and Secretary of the Board shall be elected annually by the members of the Board.

Successors in office shall be appointed not more than one (1) month after the term of the preceding member has expired. All vacancies for unexpired terms shall be filled for the remainder of the term.

A member of the Board may be removed by the Village Council for misfeasance, malfeasance, or nonfeasance in office upon written charges and after Public Hearing. A member shall disqualify himself or herself from a vote in which the member has a conflict of interest. Failure of a member to disqualify himself or herself from a vote in which the member has a conflict of interest constitutes malfeasance in office.

Section 24.03 – Alternate Members

The Village Council may additionally appoint not more than two (2) alternate members for the same term as regular members of the Zoning Board of Appeals. Any alternate members shall be selected from the electors of the Village residing within the Village. An alternate member may be called to serve on the Board of Zoning Appeals in the absence of a regular member, if the regular member will be unable to attend one (1) of more meetings. An alternate member may also be called to serve in the place of a regular member for the purpose of reaching a decision on a case in which the regular member has abstained for reasons of conflict of interest. The alternate member appointed shall serve in the case until a final decision is made. An alternate member serving on the Board has the same voting rights as a regular member of the Zoning Board of Appeals.

Section 24.04 – Meetings

Meetings of the Board shall be held at the call of the Chairperson, or in his or her absence, the acting Chairperson, and at other times as the Board in its rules of procedure may specify. All meetings shall be open to the public. The Board shall keep minutes of its proceedings, showing the vote of each member on each question, or, if absent or failing to vote, indicating such fact, and shall keep records of its findings, proceedings at hearings and other official actions, all of which shall be immediately filed in the office of the Village Clerk and shall be a public record. The Chairperson, or in his or her absence, the acting Chairperson may administer oaths and compel the attendance of witnesses.

The Board shall not conduct business unless a majority of the members of the Board are presented, and shall maintain a record of its proceedings which shall be filed in the office of the Clerk of the Village.

Section 24.05 – Powers of Zoning Board of Appeals

The Board shall have all powers and duties granted by law and by this Ordinance to such boards, including the following specific powers:

- a. To hear and decide questions that arise in the administration of the Zoning Ordinance, including, the interpretation of the Zoning Maps; and to hear and decided on matters referred to the Zoning Board of Appeals or upon which the Zoning Board Appeals is required to pass under this Ordinance.
- b. To hear and decide appeals from, and review any administrative order, requirement, decision or determination made by, an administrative official or body charged with enforcement of this Ordinance.

Section 24.06 – Application of the Variance Power

- a. A Variance may be allowed by the Board only in cases where owing to special conditions, a literal enforcement of the provisions of this Ordinance would involve practical difficulties, and when the evidence in the official record of the appeal supports all of the following affirmative findings:
 1. That the practical difficulties, or both, are exceptional and peculiar to the property of the person requesting the variance, and results from conditions which do not exist generally throughout the Village.
 2. That the practical difficulties or both, which will result from a failure to grant the variance, include substantially more than mere inconvenience, inability to attain a higher financial return, or both.
 3. That allowing the Variance will result in substantial justice being done, considering the public benefits intended to be secured by this Ordinance, the individual hardships that will be suffered by a failure of Board to grant a

Variance, and the rights of others whose property would be affected by the allowance of the Variance.

- b. The Board shall impose such conditions and requirements, in connection with any of its decisions, as it shall deem reasonable to minimize any potential detrimental effects of its decision and to promote the purposes of this Ordinance, and to accomplish the reasonable application of the foregoing standards.
- c. In exercising the above powers, the Board may reverse or affirm wholly or partly, or may modify the order, requirement, decision or determination appealed from, and may make such order, and requirement, decision or determination as ought to be made.

The authority to grant Variances from uses of land, shall only be exercised upon a two-thirds (2/3) vote of the Board of Appeals.

Section 24.07 – Limitations on the Powers of the Zoning Board of Appeals

- a. The concurring vote of the majority of the members of the Board shall be necessary:
 - 1. To reverse any order, requirement, decision, or determination of any administrative official or body; or
 - 2. To decide in favor of the applicant on any matter upon which the Board is required to pass under this Ordinance; or
 - 3. To effect any variance in this Ordinance.
- b. Every decision of the Board shall be based upon finding of fact and each and every such finding shall be supported in the record of the proceedings of the Board.
- c. Nothing contained herein shall be construed to empower the Board to change this Ordinance, to effect changes in the Zoning Map, or to add to the uses permitted in any Zoning District, except when specifically empowered to do so. The power or authority to change this Zoning Ordinance or Zoning Map is reserved to the Village Council of Leonard in the manner provided by law.

Section 24.08 – Procedure for Appeals to the Board

- a. An appeal may be taken to the Board by a person aggrieved or by an officer, department, board, or bureau of the State of Michigan or of the Village. Such appeals shall be commenced by the filing of a Notice of Appeal specifying the grounds for the appeal with the Board. The body or officer from whom the appeal is taken shall immediately transmit to the Zoning Board of Appeals all of the papers constituting the record upon which the action appealed from was taken.
- b. An appeal shall stay all proceedings in furtherance of the action appealed from unless the body or officer from whom the appeal is taken certifies to the Zoning Board of Appeals after the notice of appeal is filed that, by reason of facts stated in the certificate, a stay

would in the opinion of the body or officer cause imminent peril to life or property, in which case proceedings shall not be stayed, unless a restraining order is used by the Zoning Board of Appeals or Circuit Court.

- c. A fee shall be established by the Village Council and shall be paid through the Village Clerk to the Village Treasurer at the time notice of the appeal is filed.
- d. Following the receipt of a written request for a variance the Board shall fix a reasonable time for the hearing of the request and give written notice of the hearing as described in Article XXII - Administration and Enforcement - Section 22.08 of this Ordinance.
- e. If the Board receives a written request seeking an interpretation of the Zoning Ordinance or an appeal of an administrative decision, the Board shall conduct a Public Hearing on the request. Notice shall be given as required under Article XXII - Administration and Enforcement - Section 22.08 of this Ordinance. However, if the request does not involve a specific parcel of property, notice need only be published as provided in Article XXII - Administration and Enforcement - Section 22.08 l. and given to the person making the request by personally delivering or depositing said notice during normal business hours for delivery with the United States Postal Service or other public or private delivery service not less than fifteen (15) days before the date of the request will be considered. If the name of the occupant is not known, the term "occupant" may be used for the intended recipient of the notice.
- f. At the hearing, a party may appear in person or by agent or attorney. The Zoning Board of Appeals may reverse or affirm, wholly or partly, or modify the order, requirement, decision, or determination and may issue or direct the issuance of a Permit.
- g. The Board of Appeals shall prepare an official record for each appeal and shall base its decision on this record. The official record shall include:
 - 1. The relevant administrative records and the administrative orders issued thereon relating to the appeal.
 - 2. The Notice of Appeal.
 - 3. Such documents, exhibits, photographs, or written reports as reports as may be submitted to the Board for its consideration.
- h. The requisite written findings of fact, the conditions attached, and the decisions and orders of the Board of Appeals in disposing of the appeal, shall be entered into the official record.
- i. A copy of the official record of an appeal shall be made available for the parties to the appeal upon request.
- j. A Variance shall run with the land, except that if no building permit has been obtained within one (1) year of the effective date of the variance, the variance shall become null and void. The Board shall review any subsequent application for a Variance on the

applicable conditions and circumstances, which exist at the time of the subsequent application.

Section 24.09 – Appeal to Circuit Court

Any party aggrieved by any decision of the Board may appeal the decision to the Oakland Circuit Court in the manner provided by the laws of the State of Michigan, provided such appeal is filed with the court within whichever of the following deadlines comes first: thirty (30) days after the date the board issues its decision in writing signed by the chairperson, or within twenty-one (21) days after the Board approves the minutes of its decision.

ARTICLE XXV

SITE PLAN REVIEW

Section 25.01 – Statement of Purpose

The purpose of this Article is to provide for consultation and cooperation between the land developer and the Village in order to accomplish the developer's land utilization objectives in harmony with the existing and prospective use and development of adjacent properties. It shall be the further purpose of this Article to insure that each proposed use and its components, appearance, and function is in compliance with this Ordinance, other Village Ordinances and State and Federal Statutes. Further purposes of this Article shall include: privacy, efficiency for the public and local government servicing, preservation of the natural landscape, emergency access, effective drainage, vehicular and pedestrian safety and conveniences, control of temporary flooding, preventing stagnant water and ponding in intensively used areas; prevention of air, water and noise pollution; limitation of obnoxious odors, reduction of glare; exposure of toxic particles, substances and wastes.

The following procedures and standards should be adhered to, to accomplish these purposes.

Section 25.02 – Site Plan Approval

In each Zoning District, except for detached one family residential use and their customary accessory uses for location on a lot in a previously approved subdivision or plat, a previously approved acreage lot, or a previously approved site condominium, and permitted agricultural uses, none of the following activities may be undertaken until the Village Planning Commission has reviewed and approved a Site Plan for such use, change of use, change, or improvement:

- a. Erection, moving, relocation, conversion, or structural alteration to a building or structure to create additional floor space. A structural alteration shall be defined as one that changes the location of the exterior walls and/or the area of the building.
- b. Any condominium development including any site condominium development.
- c. A use not previously approved.
- d. Addition of land or building.
- e. Expansion, construction or maintenance of off-street parking and/or a change in circulation or access.
- f. Any excavation, grading, soil removal which causes more than fifteen (15) cubic yards of earth material to be disturbed and other than that normally incidental to single family residential uses.

Section 25.03 – Pre-Application Conference (Optional)

- a. A potential applicant seeking approval of a Site Plan may request a pre-application conference prior to filing an application. The request shall be made to the Village Clerk, who shall set a date and shall inform the Village President and the Chairperson of the Village Planning Commission of the pre-application conference and invite their attendance. The Village Clerk shall also invite other officials, consultants, or staff who might have an interest in the proposed development, or who might assist the Village in the review process.
- b. The applicant shall present at such a conference(s), at minimum, proof of interest in the property, a sketch plan of the proposed development (drawn to scale); a legal description of the property in question; the total number of acres in the project; floor area of single family, multi-family, and areas to be designated as common areas or open space.
- c. The purpose of the meeting is to inform Village and other Officials of the concept of the proposed development and provide the potential applicant with information regarding land development policies, procedures, standards and requirements of the Village in terms of the proposed development. To this end, the applicant is encouraged to present schematic plans, site data, and other information that will explain the proposed development.
- d. Statements made at the pre-application conference shall not be legally binding commitments.

Section 25.04 – Application for Site Plan Approval

Application for Site Plan Review shall be made to the Village by filing of not less than eight (8) copies of the detailed Site Plan with the office of the Building Official at least thirty (30) days in advance of the regularly scheduled Planning Commission meeting at which the Plan is to be first considered. Fees are required to be paid in accordance with the fee schedule in effect as established by the Council at the time application is made.

The Building Official shall examine the Site Plan to determine that it contains all the necessary information. If it is incomplete, it shall be returned to the applicant owner. If it is generally complete and if it appears to comply with the Zoning Ordinance, it shall be processed in accordance with this Article.

Section 25.05 – Required Information

- a. The following required information should be included on all Site Plans:
 1. Name of development and general location sketch.
 2. Name, address and phone number of owner(s), developer and designer, date drawn and revision dates shall be indicated on the Site Plan.
 3. A legal description and address of the property in question.

4. Boundary dimensions (to the nearest foot) of the property clearly indicated on the Site Plan differentiated from other contiguous property.
5. Existing zoning classification of the parcel.
6. Adjacent land uses and zoning, and if the parcel is a part of a larger parcel, boundaries of total land holding.
7. To facilitate determination of off-street parking needs and similar matters, the applicant shall indicate the name and nature of the establishments proposed to occupy the buildings if this has been determined, or shall indicate cases where exact occupancy has not yet been determined.
8. All plans shall include a north arrow and scale.
9. The area of the site excluding all existing and proposed public right-of-way.
10. The dimensions of all lots and property lines.
11. The location and dimension of all existing and proposed structures on the property and all existing structures within one-hundred (100) feet of the subject property.
12. The location and widths of all abutting streets and alleys, and driveways.
13. Traffic and pedestrian circulation patterns, and the proposed location and dimensions of sidewalks.
14. Parking lots including layout and typical dimensions of parking spaces, number of spaces provided (including how computed, per Ordinance requirements) and type of surfacing.
15. Existing ground elevations on the site of an appropriate grid or contours, including existing ground elevations of adjacent land.
16. Proposed finish grade of buildings and parking lots.
17. With residential proposals a Site Summary indicating the number and location of one (1) bedroom units, two (2) bedroom units, etc., typical floor plans with the square feet of floor areas; density computations, recreation facilities, open spaces, street names and lot coverage.
18. With non-residential proposals, the number of offices, number of employees, the number of floors and typical floor plans and cross sections.
19. Proposed sanitary sewer facilities or septic systems, and location of all existing utilities, easements, vacations and the general placement of lines, manholes, tap-ins, pump stations, and lift stations, if any.

20. Proposed storm sewer facilities (sewer and appurtenances) including outlets (enclosed or open ditches) and proposed methods of storm water retention on site, if any.
21. Sufficient off-site drainage basin data and estimated run-off to permit review of feasibility and permanency of drainage detention and/or retention.
22. Location of well.
23. Location and dimensions of rubbish storage areas and screening construction.
24. Elevations of proposed buildings and proposed type of building materials, roof design, projections, canopies and overhangs, screen walls and accessory buildings, and any other outdoor or roof-located mechanical equipment, such as: air conditioning, heating units and transformers that will be visible from the exterior.
25. Easements for public right-of-way, utilities, access, shared access, and drainage.
26. Notation of any variances which have been or must be secured.
27. Soil erosion and sedimentation control measures.
28. Landscaping plan indicating location, types, and sizes of material. A landscaping maintenance plan and schedule for pruning, mowing, watering, fertilizing, and replacement of dead and diseased materials. Cross section of any berms shall be provided.
29. Location and variety of all existing trees over twelve (12) inches in diameter. Photos of all trees and location of trees less than twelve (12) inches in diameter (directions i.e. NE, SW, etc.).
30. The dimensions and locations of all sign and lighting structures.
31. The location of any outdoor storage of material(s) and the manner in which it shall be screened or covered.
32. Information and special data which may be critical to the adequate review of the proposed use and its impacts on the site or Village. Such data requirements may include traffic studies, market analysis, environmental assessments (including inventory and impact data on flora, fauna, natural resources, hazardous materials, erosion control and pollution), demands on public facilities and services and estimates of potential costs to the Village due to failures as a basis for performance guarantees.
33. Information and statement of how applicant proposes to comply with Federal, State, Local Laws, as applicable to site or use.

34. Other data, which the Village may reasonable, deem necessary for adequate review.

Section 25.06 – Criteria for Approval of Site Plans

- a. The following criteria shall be used by the Village Planning Commission as a basis upon which Site Plans will be reviewed and approved. The Village shall adhere to sound planning principles, yet may allow for design flexibility in the administration of the following standards:
 1. All elements of the site shall be harmoniously and efficiently designed in relation to the topography, size, and type of land, and the character of the adjacent properties and the proposed use. The site will be developed so as not to impede the normal and orderly development or improvement of surrounding properties for uses permitted on such property.
 2. The Site Plan shall comply with the district requirements for minimum floor space, height of building, lot size, open space, density and all other requirements as set forth in The Regulations unless otherwise provided in this Ordinance.
 3. The existing natural landscape shall be preserved in its natural state as much as possible, by minimizing tree and soil removal and by topographic modifications that result in maximum harmony with adjacent properties.
 4. There shall be reasonable visual and sound privacy. Fences, walls, barriers, and landscaping shall be used, as appropriate, for the protection and enhancement of property and the safety and privacy of occupants and users.
 5. All buildings or groups of buildings shall be so arranged as to permit convenient and direct emergency vehicle access.
 6. Where possible and practical, drainage design shall recognize existing natural drainage patterns.
 7. There shall be pedestrian circulation system that is insulated as completely as possible from the vehicular circulation system. In order to insure public safety, pedestrian underpasses or overpasses may be required in the vicinity of schools, playgrounds, local shopping facilities, and other uses that generate considerable amounts of pedestrian movement.
 8. The arrangement of public or common ways for vehicular and pedestrian circulation shall respect the pattern of existing or planned streets or pedestrian or bicycle pathways in the vicinity of the site. Streets and drives that are a part of an existing or planned street system serving adjacent developments shall be of an appropriate width to the volume of traffic they are planned to carry and shall have a dedicated right-of-way equal to that specified in a Village recognized source of reference. The applicant may be required to dedicate adequate land and

improvements to the Village in order to achieve access, which is safe and convenient.

9. Appropriate measures shall be taken to insure that the removal of surface waters will not adversely affect adjoining properties or the capacity of the public or natural storm drainage system. Provisions shall be made for a feasible storm drainage system, the construction of storm-water facilities, and the prevention of erosion and dust. Surface water on all paved areas shall be collected at intervals so that it will not create nuisance ponding in paved areas. Final grades may be required to conform to existing and future grades of adjacent properties.
10. Off-street parking, loading and unloading areas and outside refuse storage areas, or other storage areas that face or are visible from adjacent homes, or from public thoroughfares, shall be screened by walls or landscaping of effective height. Dumpster enclosures shall have gates in accordance with the provisions of Article IV – General provisions.
11. Exterior lighting shall be so arranged and limited in intensity and height so that is deflected away from adjoining properties and so that is does not impede vision of drivers along adjacent streets.
12. Adequate services and utilities including sanitary sewers, and improvements shall be available or provided, located and constructed with sufficient capacity and durability to properly serve the development.
13. Any use permitted in any Zoning District must also comply with all applicable Federal, State, County and Local Health and Pollution Laws and Regulations with respect to noise, smoke and particulate matter, vibration, noxious and odorous matter, glare and heat, fire and explosive hazards, gases, electromagnetic radiation and drifting and airborne matter, toxic and hazardous materials, erosion control, floodplains, and requirements of the State Fire Marshall.
14. An objective of Site Plan Review shall be to protect and to promote public health, safety and general welfare by requiring the screening, buffering and landscaping of sites and parking lots which will serve to reduce wind and air turbulence, heat and noise, and the glare of automobile lights; to preserve underground water reservoirs and return precipitation to the ground water strata; to act as a natural drainage system and solve storm water drainage problems; to reduce the level of carbon dioxide and return oxygen to the atmosphere; to prevent soil erosion; to provide shade; to conserve and stabilize property values; to relieve the stark character of parking lots; to conserve energy, provide visual and sound privacy and to otherwise facilitate the preservation and creation of a healthful, convenient, attractive and harmonious community.
15. It is an objective of Site Plan Review to improve the quality of existing developments as they are expanded, contracted, redeveloped, or changed in keeping with sound Site Development Standards of the Village.

16. A major objective shall be to retain, enhance, and protect the quality, value, and privacy of single-family land uses.
17. All development phases shall be designed in logical sequence to insure that each phase will independently function in a safe, convenient, and efficient manner without being dependent upon improvements of a subsequent development potential of lands.
18. All sites shall be designed to comply with State and local barrier-free requirements and to reasonably accommodate the handicapped and elderly.
19. All site features, including circulation, parking, building orientation, landscaping, lighting, utilities, common facilities, and open space shall be coordinated with adjacent properties.

Section 25.07 – Reserved

Section 25.08 – Environmental Impact Assessment

- a. Intent: The purpose of an Environmental Impact Assessment is to assess the developmental, ecological, social, economic, and physical impacts from a proposed development on and surrounding the development site. Where required, the Environmental Impact Assessment shall, at minimum, assess the following:
 1. Water, noise, and air pollution associated with the proposed use.
 2. Effect of the proposed use on public utilities.
 3. Historic and archeological significance of the site and adjacent properties.
 4. Displacement of people and other land uses by the proposed use.
 5. Alteration of the character of the area by the proposed area.
 6. Effect of the proposed use with existing topography and topographic alterations required.
 7. Compatibility of the proposed use on surface and groundwater.
 8. Impact of the proposed use on surface and groundwater.
 9. Operating characteristics and standards of the proposed use.
 10. Proposed screening and other visual controls.
 11. Impact of the proposed use on traffic.
 12. Impact of the proposed use on flora and fauna.

13. Negative short-term and long-term impacts, including duration and frequency of such impacts, and measures proposed to mitigate such impacts.
- b. Evaluation of the Impact Assessment: The Planning Commission and Village Council shall consider the criteria listed below in their evaluation of an Environmental Impact Assessment during the Site Plan Review process. Failure to comply with any of the criteria shall be sufficient justification to deny approval of the site plan. The Village Council and Planning Commission shall determine that the proposed use:
1. Will be harmonious with and in accordance with the general objectives of the Master Plan.
 2. Will be designed, constructed, operated, and maintained in harmony with the existing or future neighboring uses.
 3. Will not be hazardous or disturbing to existing or future neighboring uses.
 4. Will represent a substantial improvement to property in the immediate vicinity and to the community as a whole.
 5. Will be served adequately by essential public services and facilities, such as highways, streets, drainage structures, police and fire protection, and refuse disposal; or that persons or agencies responsible for the establishment of the proposed use shall be able to provide adequately for such services.
 6. Will not create excessive additional requirements at public cost for public facilities and services and will not be detrimental to the economic welfare of the community.
 7. Will not involve uses, activities, processes, materials, equipment, and conditions of operations that will be detrimental to any person, property or the general welfare by reasons of excessive smoke, fumes, glare, noise, vibration, or odors.
- c. Applicability of Other Standards and Ordinances: Approval of the Environmental Impact Assessment shall not relieve the applicant from complying with other land development standards of this Ordinance, or with any other Village Ordinance, or with any other applicable local, state, or federal law or regulations.

Section 25.09 – Review of Site Plans

The Village Planning Commission may secure comments from the Village Building, Police and Fire Officials, and, as applicable, the Village Engineer, Planner and other agencies, groups or persons.

Section 25.10 – Site Plan Approval and Record

- a. The Village Planning Commission is hereby authorized to review and approve, to approve with conditions or review and deny approval, all Site Plans submitted under this

Ordinance. Guidelines for consideration of each case shall follow the Zoning Ordinance and other applicable ordinances. Each action taken with reference to Site Plan Review and approval shall be duly recorded in the Commission Minutes. When the Commission approves a Site Plan with conditions from the applicant, the Building Official shall require a revised Site Plan with a revision date, indicating said conditions on the Site Plan.

- b. When Site Plan approval is required, no Building Permit shall be issued until three (3) copies of a final Site Plan, which includes all conditions of approval, a date and notation of all Variances has been signed by the Chairman of Planning Commission, the Building Official or their designees. Prior to issuance of a permit, one (1) copy of the final signed Plan shall be filed with each of the following: Clerk, Building Official, and the Applicant. All Site Plans are valid for one (1) one year from date of signed approval.
- c. If the Village Planning Commission determines that a site plan is not sufficiently complete for approval or denial, or upon a request by the applicant, the Planning Commission may postpone consideration until a later meeting.
- d. If the Village Planning Commission denies approval for failing to comply with the standards and regulations set forth in this Ordinance, a written record shall be provided to the applicant listing the reasons for denial.
- e. If the Village Planning Commission grants approval, the following shall apply:
 - 1. In those instances in which platting is required by law, the owner or owners shall thereafter submit preliminary and final plats for the proposed development for approval in compliance with Act 288, Public Acts of 1967, as may be amended, and with all Ordinances and Regulations pertaining to the procedures and requirements for the approval of plats except to the extent that such requirements have been waived or modified by the Village Planning Commission and Village Council.
 - 2. Such plats shall be in strict conformity with the approved Site Plan, the conditions attached thereto, and the provisions of this Ordinance.

Section 25.11 – Reserved

Section 25.12 – Construction under Plan

When an applicant receives Site Plan approval as provided previously herein, the applicant shall develop the site in complete conformity with the approved Site Plan. Complete construction plans including component phases, shall be submitted for review by the Building Official. Upon review and finding by the Building Official that the construction plans meet with the requirements of Site Plan approval and other applicable Ordinances of the Village, the Building Official shall issue a Building Permit for said construction. Site Plan approval hereunder shall be valid for one (1) year from the date of approval. If the construction does not commence within six (6) months after the issuance of a Building Permit, the Site Plan Approval expires and is of

no force or effect, unless extended by the Village Building Official for one (1) six (6) month extension.

Section 25.13 – Revocation

The Planning Commission may revoke approval of a Site Plan if construction is not in conformance with the approved plans. In such case, the Site Plan shall be placed on the Agenda of the Planning Commission for consideration and written notice shall be sent to the applicant at least ten (10) days prior to the meeting. The Building Official, applicant, and any other interested persons shall be given the opportunity to present information to the Planning Commission and answer questions. If the Planning Commission finds that a violation exists and has not been remedied prior to the hearing, then it shall revoke the approval of the Site Plan.

Section 25.14 – Certificate of Occupancy

The Building Official shall withhold a Certificate of Occupancy in any case where the Site Plan and major conditions as approved by the Village Planning Commission have not been complied with. Any minor variations may be approved by the Building Official, and shall be reported to the Planning Commission within thirty (30) days and before issuance of Certificate of Occupancy.

ARTICLE XXVI

SPECIAL APPROVAL PROCEDURES AND STANDARDS

Section 26.01 – Intent

The types of uses requiring Special Approval shall be deemed to be permitted uses in their respective Zoning Districts, subject, as to each specific use, to the satisfaction of the procedures, requirements and standards set forth in this Article in a manner appropriate to the particular circumstances of such use. Each use shall be of such location, size, and character that, in general, it will not be detrimental to the orderly development of adjacent Districts and uses.

Section 26.02 – Public Hearings

Upon the request for Special Approval Use Authorization, the Planning Commission shall schedule a Public Hearing.

Section 26.03 – Procedure of Notice

Notice of the Public Hearing shall be provided as set forth in Article XXII - Administration and Enforcement - Section 22.08 of this Ordinance.

Section 26.04 – Planning Commission Hearing, Review and Recommendations

Special Approval Use shall not be granted until a Public Hearing has been held by the Planning Commission, in accordance with procedures described herein above. The Planning Commission shall make a written recommendation to the Village Council to deny, approve, or approve with conditions, requests for Special Approval Use. The recommendation on a Special Approval Use shall be incorporated in a statement of conclusions relative to the Special Approval Use under consideration. The decision shall specify the basis of the decision, and any conditions.

Section 26.05 – Decision by Village Council

The Village Council shall deny, approve, or approve with conditions, requests for Special Approval Use. The decision on a Special Approval Use shall be incorporated in a statement of findings and conclusions relative to the Special Approval Use under consideration. The decision shall specify the basis for the decision, and any conditions imposed.

Section 26.06 – Reserved

Section 26.07 – Site Plan Review and Information Required

For all Special Approval uses, a Site Plan shall be required and submitted in accordance with Article XXV- Site Plan Review of this Ordinance. Approval shall run with the land and shall not be issued for specified periods, unless the use is temporary or time-related in nature.

Section 26.08 – Performance Guarantees

Performance guarantees may be required by the Planning Commission to insure compliance with Special Approval conditions, in accordance with this Ordinance.

Section 26.09 – Standards

- a. In addition to specific Site Plan standards, which the Village may apply to the use, the following standards shall serve the Village Council as the basis for decisions involving Special Approval Uses and other discretionary decisions contained in this Ordinance. Each proposed use or activity shall:
1. Be compatible in location, size and intensity of the principal and/or accessory operations, with adjacent uses and zoning of land; and
 2. Be consistent with and promote the intent and purpose of this Ordinance; and
 3. Be compatible with the natural environment and conserve natural resources and energy; and
 4. Be consistent with existing and future capabilities of municipal services and facilities affected by the proposed use; and
 5. Demonstrated need for the proposed use within the Village; and
 6. Protect the public health, safety, and welfare as well as the social and economic well-being of those who will use the land use or activity, residents, businesses and landowners immediately adjacent and the Village as the whole; and
 7. Promote the use of land in a socially and economically desirable manner; and
 8. Not be in conflict with convenient, safe and normal neighborhood vehicular and pedestrian traffic routes, flows, intersections, and general character and intensity of neighborhood development; and
 9. Be of such a design and impact that the use, its location and height of buildings, the location, nature and height of walls, fences and the nature and extent of landscaping on the site shall not hinder or discourage the appropriate development and use of adjacent land and buildings or impair the value thereof; and
 10. In the nature, location, size and site layout and function of the use, be a harmonious part of the Zoning District in which it is situated taking into account, among other things, prevailing shopping habits, convenience of access by prospective patrons, the physical and economic relationship of one type of use to another and characteristic groupings of uses of said district; and

11. In the location, size, intensity of the use and site layout be such that operations will not be objectionable to nearby dwellings or uses, by reason of odor, noise, fumes, glare, flash of lights, radiation, or potential air, water or soil pollution.

Section 26.10 – Record

All conditions imposed on a Special Approval Use or activity shall be recorded in the record of the approval action and shall remain unchanged except upon the mutual consent of the Village Council and the applicant.

Section 26.11 – Expiration

In all cases where a Special Approval Use has been granted as provided herein, application for a building permit in pursuance thereof must be made and received by the Village not later than one (1) year thereafter, or such approval shall automatically be revoked, provided, however, the Planning Commission or Village Council may grant an extension for good cause shown under such terms and conditions and for such period of time not exceeding one (1) year as it shall determine to be necessary and appropriate.

ARTICLE XXVII

CONDITIONAL REZONING

Section 27.01 – Purpose

There are occasions when it would be in the best interests of the Village, as well as advantageous to applicants seeking a change in Zoning District designation, if certain conditions could be proposed by property owners as part of a request for a rezoning. This Section is intended to provide a process consistent with the provisions of Section 405 of the Michigan Zoning Enabling Act – Act 110 of the 2008 public acts of the Michigan Legislature (MCL 125.3405) by which an applicant seeking a rezoning may voluntarily propose conditions regarding the use and/or development of land as part of the rezoning request.

Section 27.02 – Option to Offer Condition(s)

- a. An owner of the land may voluntarily offer in writing conditions relating to the use and/or development of land for which a rezoning is requested. This offer may be made either at the time the application for rezoning is filed or may be made at a later time during the rezoning process.
- b. The required application and process for considering a rezoning request with conditions shall be the same as that for considering rezoning requests made without any offer of conditions, except as modified by the requirements of this Section.
- c. The owner's offer of conditions may not purport to authorize uses or developments not permitted in the requested new zoning district.
- d. The owner's offer of conditions shall bear a reasonable and rational relationship to the property for which rezoning is requested.
- e. Any use or development proposed as part of an offer of conditions that would require a special land use permit under the terms of this Ordinance may only be commenced if a special land use permit for such use or development is ultimately granted.
- f. Any use or development proposed as part of an offer of conditions that would require a variance under the terms of this Ordinance may only be commenced if a variance for such use or development is ultimately granted.
- g. Any use or development proposed as part of an offer of conditions that would require site plan approval under the terms of this Ordinance may only be commenced if site plan approval for such use or development is ultimately granted.
- h. The offer of conditions may be amended during the process of rezoning consideration provided that any amended or additional conditions are entered into voluntarily by the owner. An owner may withdraw all or part of its offer of conditions any time prior to final rezoning action of the Village Council provided that, if such withdrawal occurs

subsequent to the Planning Commission’s public hearing on the original rezoning request, then the rezoning application shall be referred to the Planning Commission for a new public hearing with appropriate notice and a new recommendation.

- i. The offer of conditions shall be supplemented with sufficient graphic representation if the Village Council determines that it is necessary to illustrate the conditions.

Section 27.03 – Planning Commission Review.

The Planning Commission, after public hearing and consideration of the factors for rezoning set forth in this Article, may recommend approval, approval with recommended changes or denial of the rezoning; provided, however, that any recommended changes to the offer of conditions are acceptable to and thereafter offered by the owner of the property in question.

Section 27.04 – Village Council Review.

After receipt of the Planning Commission’s recommendation, the Village Council shall deliberate upon the requested rezoning and may approve or deny the conditional rezoning request. The Village Council’s deliberations shall include, but not be limited to, a consideration of the factors for rezoning set forth in this Article. Should the Village Council consider amendments to the proposed conditional rezoning advisable and if such contemplated amendments to the offer of conditions are acceptable to and thereafter offered by the owner, then the Village shall refer such amendments to the Planning Commission for a report thereon within a time specified by the Village Council and proceed thereafter in accordance with this Article to deny or approve the conditional rezoning with or without amendments.

Section 27.05 – Approval.

- a. If the Village Council finds the rezoning request and offer of conditions acceptable, the offered conditions shall be incorporated into a formal written Statement of Conditions acceptable to the owner, the Village Council, and approved by the Village Attorney. The Statement of Conditions shall be incorporated by attachment or otherwise as an inseparable part of the Ordinance adopted by the Village Council to accomplish the requested rezoning.
- b. The Statement of Conditions shall:
 - 1. Be in a form recordable with the Register of Deeds of Oakland County.
 - 2. Contain a legal description of the land to which it pertains.
 - 3. Contain a statement acknowledging that the Statement of Conditions runs with the land and is binding upon successor owners of the land.
 - 4. Incorporate by attachment or reference any diagram, plans or other documents submitted or approved by the owner that are necessary to illustrate the implementation of the Statement of Conditions. If any such documents are

incorporated by reference, the reference shall specify where the document may be examined.

5. Contain a statement acknowledging that the Statement of Conditions giving notice thereof may be recorded by the Village with the Register of Deeds of Oakland County.
 6. Contain the notarized signatures of all of the owners of the subject land preceded by a statement attesting to the fact that they voluntarily offer and consent to the provisions contained within the Statement of Conditions.
 7. Other information as requested by the Village Council necessary to define the conditional zoning statement of conditions.
- c. Upon Village Council approval of the rezoning request, the Zoning Map shall be amended to reflect the new zoning classification along with a designation that the land was rezoned with a Statement of Conditions. The Village Clerk shall maintain a listing of all lands rezoned with a Statement of Conditions.
 - d. The approved Statement of Conditions giving notice thereof shall be filed by the Village with the Register of Deeds of Oakland County. The Village Council shall have authority to waive this requirement if it determines that, given the nature of the conditions and/or the time frame within which the conditions are to be satisfied, the recording of such a document would be of no material benefit to the Village or to any subsequent owner of the land.
 - e. Upon the rezoning taking effect, the use of the land so rezoned shall conform thereafter to all of the requirements regulating use and development within the new Zoning District as modified by any more restrictive provisions contained in the Statement of Conditions.

Section 27.06 – Compliance with Conditions.

Any person who establishes a development or commences a use upon land that has been rezoned with conditions shall continuously operate and maintain the development or use in compliance with all of the conditions set forth in the Statement of Conditions. Any failure to comply with a condition contained within the Statement of Conditions shall constitute a violation of this Zoning Ordinance and be punishable accordingly. Additionally, any such violation shall be deemed a nuisance per se and subject to judicial abatement as provided by law.

No permit or approval shall be granted under this Ordinance for any use or development that is contrary to an applicable Statement of Conditions.

Section 27.07 – Time Period for Establishing Development or Use.

- a. Unless another time period is specified in the Ordinance rezoning the subject land, the approved development and/or use of the land pursuant to building and other required permits must be commenced upon the land within eighteen (18) months after the

rezoning took effect and thereafter proceed diligently to completion. This time limitation may upon written request be extended by the Village Council if:

1. It is demonstrated to the Village Council's reasonable satisfaction that there is a strong likelihood that the development and/or use will commence within the period of extension and proceed diligently thereafter to completion, and
2. The Village Council finds that there has not been a change in circumstances that would render the current zoning with Statement of Conditions incompatible with other zones and uses in the surrounding area or otherwise inconsistent with sound zoning policy.

Section 27.08 – Reversion of Zoning.

If approved development and/or use of the rezoned land does not occur within the time frame specified in this Article, then the land shall revert to its former zoning classification. The reversion process shall be initiated by the Village Council requesting that the Planning Commission proceed with consideration of rezoning of the land to its former zoning classification. The procedure for considering and making this reversionary rezoning shall thereafter be the same as applies to all other rezoning requests.

Section 27.09 – Subsequent Rezoning of Land.

When land that is rezoned with a Statement of Conditions is thereafter rezoned to a different zoning classification or to the same zoning classification but with a different or no Statement of Conditions, whether as a result of a reversion of zoning pursuant this Article or otherwise, the Statement of Conditions imposed under the former zoning classification shall cease to be in effect. The Village Clerk shall record with the Register of Deeds of Oakland County, a notice that the Statement of Conditions is no longer in effect.

Section 27.10 – Amendment of Conditions.

- a. During the time period for commencement of an approved development or use specified in this Article or during any extension thereof granted by the Village Council, the Village shall not add to or alter the conditions in the Statement of Conditions.
- b. The Statement of Conditions may be amended thereafter in the same manner as was prescribed for the original rezoning and Statement of Conditions.

Section 27.11 – Village Right to Rezone.

Nothing in the Statement of Conditions or in the provisions of this Article shall be deemed to prohibit the Village from rezoning all or any portion of land that is subject to a Statement of Conditions to another zoning classification. Any rezoning shall be conducted in compliance with the Village of Leonard Zoning Ordinance.

Section 27.12 – Failure to Offer Conditions.

The Village shall not require an owner to offer conditions as a requirement for rezoning. The lack of an offer of conditions shall not affect an owner’s rights under this Ordinance.

Section 27.13 – Notice of Adoption.

A notice of the conditional rezoning ordinance adoption shall include a summary of conditions of approval and be published in accordance with Section 22.08 of this Ordinance.

Section 27.14 – Rezoning Factors

- a. When reviewing an application for the rezoning of land, whether the application is made with or without an offer of conditions, factors to be considered by the Planning Commission and the Village Council include, but are not limited to, the following:
 1. Whether the rezoning is consistent with the policies and uses proposed for that area in the Village Master Land Use Plan;
 2. Whether all of the uses allowed under the proposed rezoning would be compatible with other zones and uses in the surrounding area;
 3. Whether any public services and facilities would be significantly adversely impacted by a development or use allowed under the requested rezoning; and
 4. Whether the uses allowed under the proposed rezoning would be equally or better suited to the area than uses allowed under the current zoning of the land.

ARTICLE XXVIII

ENFORCEMENT AND PENALTIES

Section 28.01 – Violations and Penalties

- a. Any violation of this Ordinance shall constitute a municipal civil infraction.
 1. The following civil fines shall apply in the event of a determination of responsibility for a municipal civil infraction, unless a different fine is specified in connection with a particular Ordinance provision:
 - (a) The First Offense. The civil fine for a first offense violation shall be in an amount of Seventy-Five Dollars (\$75.00), plus costs and other sanctions, for each offense.
 - (b) First Repeat of Offense. The civil fine for any offense which is a first repeat offense shall be in an amount of One Hundred Fifty Dollars (\$150.00), plus costs and other sanctions, for each offense.
 - (c) Second (or any subsequent) Repeat of Offense. The civil fine for any offense which is a second or subsequent repeat offense shall be in an amount of Five Hundred Dollars (\$500.00), plus costs and other sanctions, for each offense.
- b. In addition to ordering the defendant determined to be responsible for a municipal civil infraction to pay a civil fine, costs, damages and expenses, the Judge or Magistrate shall be authorized to issue any judgment, writ or order necessary to enforce, or enjoin violation of, this Ordinance.
- c. Continuing Offense. Each act of violation and each day upon which any such violation shall occur, shall constitute a separate offense.
- d. Remedies Not Exclusive. In addition to any remedies provided for in this Ordinance, any equitable or other remedies available may be sought.
- e. Judge or Magistrate. The Judge or Magistrate shall also be authorized to impose costs, damages and expenses as provided by law.
- f. Default on Payment of Fines and Costs. A default in the payment of a civil fine, costs, damages or expenses ordered under Subsection a or b or an installment of the fine, costs, damages or expenses as allowed by the court, may be collected by the Village of Leonard by a means authorized for the enforcement of a judgment under Chapters 40 or 60 of the Revised Judicature Act, MCL 600.101, et. seq., MSA 27A.101, et. seq., as amended.

- g.** Failure to Comply With Judgment or Order. If a defendant fails to comply with an order or judgment issued pursuant to this Section within the time prescribed by the court, the court may proceed under Subsection i.
- h.** Failure to Appear in Court. A defendant who fails to answer a citation or notice to appear in court for a violation of this Ordinance is guilty of a misdemeanor, punishable by a fine of not more than Five Hundred Dollars (\$500.00), plus costs and/or imprisonment not to exceed ninety (90) days.
- i.** Civil Contempt.
1. If a defendant defaults in the payment of a civil fine, costs, damages, expenses, or installment as ordered by the district court, upon motion of the Village of Leonard or upon its own motion, the court may require the defendant to show cause why the defendant should not be held in civil contempt and may issue a summons, order to show cause, or bench warrant of arrest for the defendant's appearance.
 2. If a corporation or an association is ordered to pay a civil fine, costs, damages or expenses, the individuals authorized to make disbursements shall pay the fine, costs, damages or expenses, and their failure to do so shall be civil contempt unless they make the showing required in this Subsection i.
 3. Unless the defendant shows that the default was not attributable to an intentional refusal to obey the order of the court or to a failure on his or her part to make a good faith effort to obtain the funds required for payment, the court shall find that the default constitutes a civil contempt and may order the defendant committed until all or a specified part of the amount due is paid.
 4. If it appears that the default in the payment of a civil fine, costs, damages or expenses does not constitute civil contempt, the court may enter an order allowing the defendant additional time for payment, reducing the amount of payment or of each installment or revoking the fine, costs, damages or expenses.
 5. The term of imprisonment on civil contempt for nonpayment of a civil fine, costs, damages or expenses shall be specified in the order of commitment and shall not exceed one day for each Thirty Dollars (\$30.00) due. A person committed for nonpayment of a civil fine, costs, damages or expenses shall be given credit toward payment for each day of imprisonment and each day of detention in default of recognizance before judgment at the rate of Thirty Dollars (\$30.00) per day.
 6. A defendant committed to imprisonment for civil contempt for nonpayment of a civil fine, costs, damages or expenses shall not be discharged from custody until one of the following occurs:
 - (a) Defendant is credited with an amount due pursuant to Subsection i(5).
 - (b) The amount due is collected through execution of process or otherwise.

(c) The amount due is satisfied pursuant to a combination of Subsection i(6)(a) and (b).

7. The civil contempt shall be purged upon discharge of the defendant pursuant to Subsection i(6).

j. Other Rights or Remedies Not Affected: The rights and remedies provided in this Ordinance are cumulative and shall be deemed to be in addition to, and shall not adversely effect, any and all other rights and remedies provided by law.

k. Remedies Not Exclusive: In addition to any remedies provided for in this Ordinance, any equitable or other remedies available may be sought.

l. Rights and Remedies Preserved, No Waiver: Any failure or omission to enforce the provisions of this Ordinance, and any failure or omission to prosecute any violations of this Ordinance, shall not constitute a waiver of any rights and remedies provided by this Ordinance or by law, and shall not constitute a waiver of nor prevent any further prosecution of violations of this Ordinance.

Section 28.02 – Public Nuisance

A violation of any of the provisions of this Ordinance is hereby declared to be public nuisance per se. The Board of Appeals, any person designated by the Council or any aggrieved person may institute a suit in a court of law to have the nuisance abated.

ARTICLE XXIX
RESERVED

ARTICLE XXX
RESERVED

ARTICLE XXXI
RESERVED

ARTICLE XXXII
RESERVED

ARTICLE XXXIII

AMENDMENTS AND NOTICES

Section 33.01 – Statement of Intent

For the purpose of establishing and maintaining sound, stable and desirable development within the territorial limits of the municipality, the Village Council of the Village of Leonard may, from time to time, on recommendation from the Planning Commission, or on its own motion, or on petition, amend, supplement, modify, or change the zoning district boundaries shown on the Zoning Map or the provisions of this Ordinance in accordance with the authority of Michigan Public Act 110 of the Public Acts or 2006, as amended. A petition for amendment of this Ordinance by a resident or property owner of the Village shall be accompanied by a fee. The amount of such fee shall be set by a resolution of the Village Council and shall be used to defray the expense of publishing the required notices, the expense of the Planning Commission in considering the petition, and the expense related to the Village consultants review of the petition.

Section 33.02 – Amendment Procedure

- a. All applications for amendments to this Ordinance, except those initiated by the Village Council or Planning Commission, shall be in writing, signed, and filed in triplicate with the Village Clerk. All applications for amendments to this Ordinance, without limiting the right to file additional material, shall contain the following:
 1. The applicant's name, address and interest in the application as well as the name address and interest of every person, firm, or corporation having a legal or equitable interest in the land.
 2. The nature and effect of the proposed amendments.
 3. If the proposed amendment would require a change in the Zoning Map, a fully dimensioned drawing showing the land which would be affected by the proposed amendment, a complete legal description of the land, the present zoning classification of the land, the zoning classification of all abutting districts, all public and private rights-of-way and easements bounding and intersecting the land under consideration.
 4. If the proposed amendment would require a change in the Zoning Map, the names and addresses of the owners of all land and their legal descriptions within the area to be changed by the proposed amendment;
 5. The alleged error in this Ordinance which would be corrected by the proposed amendment, with a detailed explanation of such alleged error and detailed reasons the proposed amendment will correct the same;

6. The changed or changing conditions in the area or in the municipality that make the proposed Amendment reasonably necessary to the promotion of the public health, safety, and general welfare;
 7. All other circumstances, factors, and reasons which applicant offers in support of the proposed Amendment.
- b. The Village Clerk, upon receipt of an application to amend or request to amend by the Council or Planning Commission, shall refer such application to the Village Planning Commission for study and report. A Public Hearing on the proposed Amendment shall be held by the Planning Commission before any proposed Amendment to this Ordinance is affected. Notice of the Public Hearing shall be given by publishing said notice at least once in a newspaper of general circulation in the municipality stating the time and place of such hearing and the substance of the proposed Amendment. This notice shall appear in said newspaper not less than fifteen (15) days prior to the date set for the public hearing. Such notice shall also be mailed to each electric, gas, and pipeline public utility company, each telecommunication service provider, and to each railroad company owning or operating any public utility or railroad within the Zoning Districts affected by the proposed Amendment that registers its name and mailing address with the Village for the purpose of receiving such notice. The notice shall be given not less than fifteen (15) days before the public hearing date. The notice shall describe the nature of the proposed amendment, state the time and place of the public hearing, and indicate when and where written comments will be received.
 - c. If an individual property or ten (10) or fewer adjacent properties are proposed for rezoning, the Village shall give a written notice of the proposed rezoning to the owner of the property in question, to all persons to whom any real property within three-hundred (300) feet of the premises in question is assessed, and to the occupants of all structures within three-hundred (300) feet, regardless of whether the property or occupant is located within the Village of Leonard. The notice shall be delivered personally or by mail to the respective owners and tenants at the address given in the last assessment roll. If the tenant's name is not known, the term "occupant" may be used. If the notice is delivered by mail, an affidavit of mailing shall be filed with the Village before the hearing. The Village Clerk shall maintain an affidavit of such mailing.
 - d. After the Public Hearing held by the Planning Commission, the Village Council may adopt the proposed amendment. The Council may decline to adopt the proposed amendment or may adopt it in whole, in part, or with or without additional change. The Council may also refer to proposed amendment back to the Planning Commission for further study and review or additional Public Hearings.
 - e. The Village Council shall provide an opportunity to be heard before the Council to an interested property owner who requests a hearing by certified mail, addressed to the Clerk of the Village. A hearing for this purpose is not subject to the notice requirements of this Article, except that notice shall be given to the interested property owner in the manner required in this Article.

Section 33.03 – Protests

In case a protest against a proposed Amendment is presented to Village Council before a decision is made, duly signed by the owners of at least twenty (20%) percent of the land proposed to be altered, or by the owners of at least twenty (20%) percent of the area of land included within the area extending outward one hundred (100) feet from any point on the boundary of the land included in the proposed change, such amendment shall not be passed except by the three-fourths ($\frac{3}{4}$) vote of the Village Council.

ARTICLE XXXIV

INTERPRETATION AND VESTED RIGHT

Section 34.01 – Interpretation and Conflict

In interpreting and applying the provisions of this Ordinance, said provisions shall be held to be the minimum requirements for the promotion of the public safety, health, convenience, comforts, prosperity and general welfare.

It is not intended by this Ordinance to interfere with or abrogate or annul any ordinance, rules, regulations or permits previously adopted or issued and not in conflict with any of the provisions of this Ordinance, or which shall be adopted or issued pursuant to law relating to the use of buildings or premises and likewise not in conflict with this Ordinance; nor is it intended by this Ordinance to interfere with or abrogate or annul any easements, covenants or other agreements between parties; provided, however, that where this Ordinance imposes a greater restriction upon the use of buildings or premises or upon height of buildings, or requires larger open spaces or larger lot areas than are imposed or requires by such other ordinance or agreements, the provisions of this Ordinance shall control.

Section 34.02 – Vested Right

It is hereby expressly declared that nothing in this Ordinance be held or construed to give or grant to any person, firm or corporation any vested right, license, privilege or permit.

ARTICLE XXXV

REPEALER, SEVERABILITY, EFFECTIVE DATE, ADOPTION

Section 35.01 – Repealer

All other ordinances or parts of ordinances in conflict with this Ordinance are hereby repealed only to the extent necessary to give this Ordinance full force and effect.

Section 35.02 – Severability

Should any provision or part of this Ordinance be declared by any court of competent jurisdiction to be invalid or unenforceable, the same shall not affect the validity or enforceability of the balance of this Ordinance, which shall remain in full force and effect.

Section 35.03 – Savings Clause

Nothing in this Ordinance shall be construed to affect any suit or proceeding pending in any court or any rights acquired or any liability incurred, or any cause or causes of action acquired or existing, under any act or ordinance hereby repealed as cited in Section 31.01 of this Ordinance; nor shall any just or legal right or remedy of any character be lost, impaired, or affected by this Ordinance.

Section 35.04 – Adoption

This Ordinance was adopted as Ordinance No. 19 by the Village Council of the Village of Leonard at its regular meeting duly held on August 12, 2013 following compliance with all procedures required by the Michigan Zoning Enabling Act (P.A. 110 of 2006, as amended), and ordered to be given publication in the manner prescribed by law.

Section 35.05 – Effective Date

This Ordinance is hereby declared to be effective upon the expiration of seven days following publication as required by law.

Dated: _____

Cindy Grosskopf, Clerk

Dated: _____

Michael McDonald, President

PUBLICATION

I certify that this Ordinance was published in the manner prescribed by law in the Oxford Leader newspaper, on the ____ day of _____, 2013, said newspaper being in general circulation in the Village of Leonard.

Cindy Grosskopf