

ZONING RESOLUTION
SCIOTO TOWNSHIP
PICKAWAY COUNTY, OHIO

Effective January 14, 2011
Updated October, 2019

Article XXVI	(DCC) Darby Creek Conservation District.....	131
Article XXVII	(ANO) Airport Noise Overlay District	133
PART FOUR	ADDITIONAL ZONING REQUIREMENTS	135
Article XXVIII	General Development Requirements	136
Article XXIX	Accessory Uses and Structures	139
Article XXX	Off-Street Parking Requirements.....	149
Article XXXI	Signs.....	155
Article XXXII	Adult Entertainment Businesses	165
Article XXXIII	Temporary Uses	168

PART ONE

GENERAL PROVISIONS

ARTICLE I

AUTHORIZATION AND PURPOSE

Section 1.01 Title

This Resolution shall be known and may be cited as the *Zoning Resolution of Scioto Township, Pickaway County, Ohio*. Unless otherwise provided herein or by the law or implication required, the same rules of construction, definition, and application shall govern the interpretation of the Resolution as those governing the interpretation of the Ohio Revised Code.

Section 1.02 Purpose

This Zoning Resolution is adopted to promote and protect the public health, safety, convenience, comfort, prosperity and general welfare by regulating and limiting the use of land areas and the construction, restoration and/or alteration of buildings and uses therein, for residential, business and industrial purposes; to regulate and restrict the bulk, height, density and location of buildings; to protect the character of the existing agricultural, residential, business, industrial and institutional areas and unique environmental resources; to assure the orderly growth and development of lands, and for the purpose of dividing the Township into various districts all in accordance with Chapter 519 of the Ohio Revised Code.

Section 1.03 Applicability and Limitations

Subject to the limitations specified under applicable law, the regulations set forth in this Zoning Resolution shall be applicable to all buildings, structures, uses and lands of any private individual or entity, or any political subdivision, district taxing unit or bond-issuing authority, located within the unincorporated area of Scioto Township, Pickaway County, Ohio.

Section 1.04 Interpretations and Consistency

In their interpretation and application, the provisions of this Resolution shall be held to be the minimum requirements. Where the provisions of this Resolution impose greater restrictions upon buildings, structures, uses or land than required by other provisions of law, or by other rules, regulations, resolutions or restrictions, the regulations of this Resolution shall govern. Conversely, where the provisions of this Resolution are less restrictive, the more restrictive provision of the other laws, rules, regulation or restrictions shall control. These regulations shall not be deemed or construed to repeal, amend, modify, alter or change any other law, resolution or regulation of Scioto Township, or part thereof, not specifically repealed, amended, modified, altered or changed herein.

Section 1.05 Separability

The invalidation of any clause, sentence, paragraph, or section of this Resolution by a court of competent jurisdiction shall not affect the validity of the remainder of this Resolution either in whole or in part.

ARTICLE II

DEFINITIONS

Section 2.01 Interpretation

For the purpose of this Zoning Resolution, certain terms and words are to be defined as found in this Article. Words and terms not specifically defined carry their customarily understood meanings. Words used in the present tense include the future tense. The singular form shall include plural and plural shall include singular. The word “shall” is mandatory. “Occupied” or “used” shall be considered as though followed by the words “or intended, arranged or designed to be used or occupied”.

Particular terms directly related to topics may be defined within specific sections of the Resolution where those general requirements are found.

Section 2.02 Definitions

“**Accessory use**” means a use subordinate, secondary, incidental to, and customary in connection with the principal building or use and located on the same lot as the principal building or use.

“**Accessory building**” or “**accessory structure**” means a subordinate building or structure detached from, but located on the same lot as the principal building, the use of which is incidental and accessory to that of the principal building.

“**Administrative and business offices**” means offices which carry on no retail trade with the public and maintain no stock of goods for sale to customers.

“**Adult care facility**” means an adult family home or an adult group home. For the purposes of this Resolution, any residence, facility, institution, hotel, congregate housing project, or similar facility that provides accommodations and supervision to three to sixteen unrelated adults, at least three of whom are provided personal care services, is an adult care facility regardless of how the facility holds itself out to the public. Adult care facility does not include:

- (1) a facility operated by a hospice care program licensed under Section 3712.04 of the Ohio Revised Code that is used exclusively for care of hospice patients;
- (2) a nursing home, rest home, or home for the aging as defined in Section 3721.01 of the Ohio Revised Code;
- (3) a community alternative home as defined in Section 3724.01 of the Ohio Revised Code; and

- (4) an alcohol and drug addiction program as defined in Section 3793.01 of the Ohio Revised Code.

“Adult family home” means, as defined in Chapter 3722 of the Ohio Revised Code, a residence or facility that provides accommodations to three to five unrelated adults and supervision and personal care services to at least three adults. An “adult family home” is a permitted use in all residential zoning districts.

“Adult group home” means, as defined in Chapter 3722 of the Ohio Revised Code, a residence or facility that provides accommodations to six to sixteen unrelated adults and provides supervision and adult personal care services to at least three of the unrelated adults.

“Building” means a structure having a roof supported by columns or walls, used or intended to be used for shelter or enclosure of persons, animals and/or property.

“Height of building” means the vertical distance from the average grade surrounding the building to the highest point of the roof.

“Building line” means the front yard setback line established by this Zoning Resolution, generally parallel with and measured perpendicularly from the front lot line, defining the limits of a front yard in which no building or structure may be located.

“Business services” means any profit-making activity which renders services primarily to other commercial, institutional, or industrial enterprises, or which services and repairs appliances and machines used in other businesses.

“Cemetery” means land used or intended to be used for the burial of human or animal dead and dedicated for cemetery purposes, including crematories, mausoleums and mortuaries if operated in connection with and within the boundaries of such cemetery.

“Child Day Care Type B Home” means a permanent residence of the provider in which child day-care services are provided for one to six children at one time and in which no more than three children may be under two years of age at one time. In counting children for the purpose of this provision, any children under six years of age who are related to the provider and who are on the premises of the Type B home shall be counted. A Type B family day-care home does not include a residence in which the needs of children are administered to, if all of the children are siblings of the same immediate family and the residence is the home of the siblings.

“Clinic, Human” means an establishment where patients who are not lodged overnight are admitted for examination and/or treatment by a physician or group of physicians.

“Conditional use” means an uncommon or infrequent use which may be permitted in specific zoning districts subject to compliance with certain standards, explicit conditions, and the granting of a conditional use permit as specified in Article IX of this Resolution.

“Congregate or group home” means a residential care facility in which not less than nine (9) but not more than sixteen (16) persons are provided with room, board, specialized care, rehabilitative services and supervision in a family environment.

“Development” means any man-made change to improved or unimproved real estate, including but not limited to buildings or other structures, mining, dredging, filling, grading, paving, excavation or drilling operations or storage of equipment or materials.

“District” means a part, portion, zone or geographic area within Scioto Township within which certain development standards, as delineated by this Resolution, apply.

“Dwelling” or **“residence”** means any building or portion thereof which is designed or used for residential purposes, but not including a cabin, hotel, motel, rooming house, or other such accommodation used for transient occupancy.

“Single family dwelling” or **“single family residence”** means a building designed for or occupied exclusively by one family.

“Two-family dwelling” or **“two-family residence”** means a building designed for or occupied exclusively by two families living independently.

“Multiple-family dwelling” or **“multiple-family residence”** means a building designed or used as a residence for three or more families living independently and doing their own cooking therein.

“Federal Emergency Management Agency (FEMA)” means the agency with the overall responsibility for administering the National Flood Insurance Program.

“Flood” or **“flooding”** means a general and temporary condition of partial or complete inundation of normally dry land areas from:

- (1) The overflow of inland or tidal waters and/or
- (2) The unusual and rapid accumulation of runoff of surface waters from any source.

“Flood Insurance Rate Map (FIRM)” means an official map on which the Federal Emergency Management Agency has delineated the areas of special flood hazards within Scioto Township and/or Pickaway County

“Floodway” means the channel of a creek, stream or other watercourse and the adjacent lands that must be reserved in order to discharge the base flood without cumulatively increasing the water surface elevation more than one (1) foot.

“Floor area” of a building means the sum of the gross horizontal areas of the building floors, measured from the exterior faces of exterior walls. Floor area shall not include basements, elevator and stair bulkheads, unfinished attic spaces, terraces, breezeways, open porches, uncovered steps, or garages.

“Frontage” or **“lot frontage”** means the distance of that portion of the lot that directly abuts the street, and has direct access thereto. In the case of a corner lot, frontage requirements shall be measured and met along both right-of-way lines.

“Home occupation” means any occupation or profession conducted primarily by immediate resident family members, which is clearly incidental and secondary to the dwelling's residential use. A home occupation must meet the standards and requirements specified in Section 29.02 of this Resolution.

“Hospital” means a building or structure containing beds for at least four (4) patients allowing for overnight or continuous care, diagnosis and treatment of human ailments.

“Industrialized unit” means a building unit or assembly of closed construction that is fabricated in an off-site facility, that is substantially self-sufficient as a unit or as a part of a greater structure that requires transportation to the site of intended use. “Industrialized unit” includes units installed on the site as independent units, as part of a group of units, or incorporated with standard construction methods to form a completed structural entity. “Industrialized unit” does not include a manufactured or mobile home as defined herein.

“Institution” means an organization providing social, cultural, and educational or health services to member agencies, organizations, and individuals, or to the general public.

“Lot” means a division of land separated from other divisions for purposes of sale, lease, or separate use, described on recorded subdivision plat, recorded map or by metes and bound, and includes the terms “plat” and “parcel”.

“Corner lot” means a lot abutting two (2) or more streets at their intersection, or abutting two (2) parts of the same street, and, in either case, forming an interior angle of 135 degrees or less as measured at the center line of the road or the interior right-of-way line, as applicable.

“Lot coverage” means the ratio of enclosed ground floor area of all buildings and/or pavement areas on a lot to the horizontally projected area of the lot, expressed as a percentage.

“Front lot line” means that lot line which either falls along a street right-of-way line or falls approximately along the center line of the right-of-way. On a corner lot, lot lines along both streets shall be considered front lot lines.

“Rear lot line” means that lot line which is opposite and furthest removed from the front lot line. If a rear lot line is less than fifteen (15) feet long, or if the lot comes to a point, the rear lot line shall be a line at least fifteen (15) feet long, lying wholly within the lot, parallel to, and a maximum distance from, the front lot line. In the case of a corner lot, the rear lot line shall be the lot line opposite the shortest front lot line.

“Side lot line” means a lot line which is neither a front or a rear lot line.

“Lot of record” means any lot which individually or as a part of a subdivision has been recorded in the Office of the Recorder, Pickaway County, Ohio, as of the effective date of this Resolution.

“Minimum area of lot” means the area of a lot computed exclusive of any portion of the right-of-way or any public thoroughfare.

“Lot width” is the width of a lot as measured along the front lot line that abuts a publicly dedicated and improved thoroughfare.

“Manufactured home” means a building unit or assembly of closed construction that is fabricated in an off-site facility, that conforms with the federal construction and safety standards established by the Secretary of Housing and Urban Development pursuant to the *Manufactured Housing Construction and Safety Standards Act of 1974*, and has a label or tag permanently affixed to it, certifying compliance with all applicable federal construction and safety standards.

“Manufactured home community” or **“Manufactured Home Park”** means a development constructed primarily for manufactured homes, with continuing local management and special facilities for common use by residents. Typically, the land or lots upon which the manufactured homes are located will not be owned by residents of the individual manufactured home.

“Mobile home” means a building unit or assembly of closed construction that is fabricated in an off-site facility, is more than thirty-five (35) feet in length, or, when erected on the site, is 320 or more square feet, that is built on a permanent chassis and is transportable in one or more sections, and does not qualify as a manufactured home or industrialized unit, as defined herein.

“Modular home” means a non-site-built home that is certified as meeting the requirements of the State of Ohio Building Code for *modular housing*. For the purposes of this Resolution, once certified by the State of Ohio, modular homes shall be subject to the same standards as site-built homes.

“Municipal waste storage facility” – An impoundment area or storage vessel (tank) constructed for the purpose of storing municipal waste, including but not limited to: sewage, industrial waste, human waste, chemical waste, hospital waste or other hazardous waste treated or untreated and does not include animal waste generated by agricultural production.

“Nonconforming building or structure” means a building or structure lawfully existing at the time of enactment of this Resolution or subsequent amendments, which does not conform to the regulations of the district in which it is situated or other applicable provisions of this Resolution.

“Nonconforming lot” means a lot existing at the time of enactment of this Resolution or any subsequent amendments which does not conform to the lot area and frontage requirements of the district in which it is located.

“Nonconforming use” means a use of land lawfully existing at the time of enactment of this Resolution or subsequent amendments, which does not conform to the regulations of the district in which it is situated or other applicable provisions of this Resolution.

“Nursery” or **“day care center”** means a facility which temporarily assumes responsibility for more than four (4) children other than those related to the resident of the premises. Such responsibility shall consist of administering to the needs of those children during any part of a twenty-four-hour day for a period of two (2) consecutive days. A “nursery” or “day care center” shall not include a “Child Day Care Type B Home.”

“Nursing home” includes convalescent and extended care facilities; an establishment which specializes in providing necessary care, shelter and nursing services and services to those unable to be responsible for themselves.

“Off-street parking space” means any parking space located wholly off any street, alley, or sidewalk, either in an enclosed building or on an open lot and where each parking space conforms to the standards as specified in this Ordinance.

“Parking area” or **“parking lot”** means any area other than street, drive, or alley used or intended to be used for the storage of motor vehicles, with or without a fee.

“Permanent foundation” means a permanent masonry, concrete or locally approved footing or foundation, to which a manufactured home may be affixed.

“Permanently sited manufactured home” means a manufactured home designed for or occupied exclusively by one family that meets all of the following criteria:

- (1) The structure is affixed to a permanent foundation (i.e. permanent masonry, concrete or locally approved footing or foundation) and is connected to appropriate facilities (i.e. water, sewer, electric, telephone, gas, etc.);
- (2) The structure, excluding any addition, has a width of at least twenty-two (22) feet at one point, a length of at least twenty-two (22) feet at one point, and a living area of at least 900 square feet (or such greater square footage as is uniformly required by applicable district regulations), excluding garages, porches, or attachments;
- (3) The structure has a minimum 3:12 roof pitch, conventional residential siding, and a six-inch minimum eave overhang, including appropriate guttering;
- (4) The structure was manufactured after January 1, 1995 and all indicia of mobility are removed prior to placement on its foundation;
- (5) The structure is not located in a manufactured home community or manufactured home park as defined herein;
- (6) The structure meets all zoning requirements uniformly imposed (i.e. minimum lot size; setbacks; floor area; etc.) on all single-family dwellings in the district (excepting contrary requirements for minimum roof pitch and requirements that do not comply with HUD code standards for manufactured housing). A permanently sited manufactured home, as defined, shall be classified as a single-family dwelling.

“Person” means any individual, corporation, company, business, partnership, association or legal entity.

“Personal services” means any enterprise, conducted for gain, which primarily offers services to the general public such as shoe repair, watch repair, retail dry cleaning, barber and beauty shops, and related activities.

“Professional offices” means the offices which engage in the providing to the general public services of a professional nature such as legal, medical, accounting, and architectural services.

“Public Park” means an active or passive recreational facility which is owned and operated by a governmental entity (e.g. federal, state or local) and which is open to and for the benefit of the general public.

“Recreational facilities” means public or privately-operated uses such as country clubs, golf courses, swimming pools, or other areas maintained for the purpose of providing active and passive recreation.

“Residence” - see “Dwelling”.

“Restaurant” means a business establishment where food and beverages are prepared and presented for human consumption on the premises.

“Retail store” means a store primarily engaged in selling merchandise for personal or household consumption and in rendering services incidental to the sale of goods.

“Right-of-way” means a strip of land taken or dedicated for use as a public way. In addition to the roadway, it normally incorporates the curbs, lawn strips, sidewalks, lighting and drainage facilities, and may include special features required by the topography or treatment such as grade separation, landscaped areas, viaducts and bridges.

“Street”, “road” or “thoroughfare” means a public way for the purpose of vehicular travel, including the entire area within the right-of-way.

“Structure” means any production or piece of work composed of parts joined together in some definite manner, the use of which requires location or placement on the ground or attachment to something having a fixed location on the ground. The term “structure” includes, among other things, walls, buildings, and patios, but does not include fences.

“Structural alteration” means any change which would replace or tend to prolong the life of a supporting member of a structure, such as bearing walls, columns, beams, or girders.

“Township” means Scioto Township, Pickaway County, Ohio.

“Use” means the purpose for which a building is arranged, designed, or intended, or for which either land, lot, piece or parcel thereof or a building located thereon or may be occupied or maintained.

“Variance” means a modification from the strict terms of the relevant regulations where such modification will not be contrary to the public interest and where owing to conditions peculiar to the property and not the result of action by the applicant, a literal enforcement of the regulations would result in unnecessary and undue hardship.

“Veterinary clinic” means a place used for the care, grooming, diagnosis and treatment of sick, ailing, infirm or injured animals, and those which are in need of medical or surgical attention, and may include overnight accommodations on the premises for treatment, observation and/or recuperation. It may also include boarding that is incidental to the primary activity.

“Yard” means a required open space other than a court unoccupied and unobstructed by any structure or portion of a structure from three (3) feet above the general level of the graded lot upward.

“Front yard” means that portion of a lot extending across the front of the lot between the side lot lines and being the minimum horizontal distance between the street right-of-way and the front of the building or structure. On a corner lot or through (double frontage) lot, the principal building and all accessory structures shall meet the front yard requirements of the district from all right-of-way lines.

“Rear yard” means that portion of a lot extending the full width of the lot between a building or structure and the rear lot line and being the required minimum horizontal distance between the rear lot line and the rear of the building or structure.

“Side yard” means that portion of a lot extending from the front yard to the rear yard between a building or structure and the nearest side lot line unoccupied and unobstructed from the ground upward except as herein specified.

“Zoning permit” means an official statement certifying that a proposed building or use complies with all the provisions of this Zoning Resolution.

“Zoning District” means a portion of the Township within which certain regulations and requirements or various combinations thereof apply under the provisions of this Zoning Resolution.

“Zoning District Map” or **“Zoning Map”** means the map of the Township showing the locations of established zoning districts, together with all amendments subsequently adopted by the Township Trustees, and established pursuant to Section 12.02 of this Resolution.

“Zoning Inspector” means the enforcement officer, hired by the Board of Township Trustees, who is charged with enforcing the provisions of this Zoning Resolution.

PART TWO

ADMINISTRATION AND ENFORCEMENT

ARTICLE III

ADMINISTRATIVE BODIES AND THEIR DUTIES

Section 3.01 Zoning Inspector

3.01.01 Office of Zoning Inspector Established

The Zoning Inspector, together with such assistants, all as appointed by the Board of Township Trustees for an indefinite term, shall enforce the Zoning Resolution. All officials and/or employees of the Township shall assist the Zoning Inspector by reporting any new construction, reconstruction, or apparent violations to this Resolution.

3.01.02 Intentionally Left Blank

3.01.03 Immunities

The Zoning Inspector shall be entitled to all rights, privileges and immunities afforded such officer under applicable law.

3.01.04 Duties of Zoning Inspector

For the purposes of this Resolution, the Zoning Inspector shall have the following duties:

- A. Enforce the Zoning Resolution and take all necessary steps to remedy conditions found in violation by ordering, in writing, the discontinuance of illegal uses or work in progress, and direct cases of noncompliance to the Board of Zoning Appeals or other appropriate entity for action.
- B. Issue zoning certificate(s) when the provisions of the Zoning Resolution have been met, or refuse to issue same in the event of noncompliance.
- C. Collect the designated fees for zoning certificates, amendments, and applications for appeals, variances and conditional uses, as established by separate resolution.
- D. Make and keep all records necessary and appropriate to the office including records of issuance and denial of zoning certificates and receipt of complaints of violation of the Zoning Resolution and action taken on same.
- E. Inspect buildings or lands to determine whether any violations of the Zoning Resolution have been committed or exist.
- F. Advise the Zoning Commission and the Board of Zoning Appeals of all matters, other than routine duties, pertaining to the enforcement of and amendments to the Zoning Resolution.
- G. Review all zoning applications.
- H. Provide assistance, as needed, to Trustees, Board of Zoning Appeals, Zoning Commission, Township Counsel and other governmental authorities as appropriate.

Section 3.02 Township Zoning Commission

3.02.01 Establishment

Pursuant to Ohio Revised Code Chapter 519, there is hereby established a Township Zoning Commission in and for Scioto Township. Such Commission shall consist of five (5) residents of the unincorporated area of the Township as appointed by the Board of Township Trustees. The terms and conditions of tenure of the members shall be arranged by the Board of Township Trustees. The Board of Trustees may appoint two (2) alternate members to the Zoning Commission in accordance with Section 519.04 of Ohio Revised Code.

3.02.02 Removal from Office

Members of the Zoning Commission shall be subject to removal as specified in Section 519.04 of the Ohio Revised Code

3.02.03 Proceedings

The Commission shall organize annually and elect a Chairman and such other officers as necessary, and appoint a Secretary. Meetings of the Commission shall be held at the call of the Chairman and at other such times as the Commission shall determine. The Commission shall adopt, from time to time, such rules and regulations as it may deem necessary to perform its powers and duties. All meetings of the Commission shall be open to the public.

The Secretary of the Commission shall keep minutes of its proceedings, showing the vote of each member upon each question; or, if absent or failing to vote, indicating such fact; and shall keep records of its official action, all of which shall be a public record and immediately filed in the Township offices. For the purpose of taking action, the concurring vote of three (3) members of the Commission shall be required.

3.02.04 Powers and Duties

For the purposes of this Resolution, the Township Zoning Commission shall, in addition to those set forth under applicable law, have the following powers and duties:

- A. Initiate amendments to this Resolution, pursuant to Article VI.
- B. Review proposed amendments to this Zoning Resolution and make recommendations to the Board of Township Trustees.

Section 3.03 Board of Zoning Appeals

3.03.01 Establishment

There is hereby established a Board of Zoning Appeals which shall have the authority as specified in Sections 519.13 through 519.15 of the Ohio Revised Code, subject to such rules of a procedural nature as said

Board may adopt and promulgate for the purposes of expeditiously acting on matters properly before it.

The Board of Zoning Appeals shall consist of five (5) members appointed by the Board of Township Trustees. Every member shall be a resident of the unincorporated territory of Scioto Township, Pickaway County, Ohio. The terms of members shall be of such length and so arranged that the term of one member shall expire each year; however, each member shall serve until his/her successor is appointed. Vacancies shall be filled by the Board of Township Trustees for the unexpired term of the member affected. The Board of Trustees may appoint two (2) alternate members to the Board of Zoning Appeals in accordance with Section 519.13 of the Ohio Revised Code.

3.03.02 Removal from Office

Members of the Board of Zoning Appeals shall be subject to removal as specified in Section 519.13 of the Ohio Revised Code.

3.03.03 Proceedings

The Board shall organize annually and elect a Chairman and such other officers as necessary, and appoint a Secretary. Meetings of the Board shall be held at the call of the Chairman and at other such times as the Board shall determine. The Board shall adopt, from time to time, such rules and regulations as it may deem necessary to implement the provisions of this Zoning Resolution.

The Secretary of the Board shall keep minutes of its proceedings, showing the vote of each member upon each question; or, if absent or failing to vote, indicating such fact; and shall keep records of its examinations and other official action, all of which shall be a public record and immediately filed in the Township offices.

The Board shall have the power to subpoena witnesses, administer oaths and may require the production of documents under such rules as it may establish.

3.03.04 Powers and Duties

In exercising its duties, the Board may, as long as such action is in conformity with the terms of this Resolution, reverse or affirm, wholly or partly, or modify the order, requirement, decision, or determination appealed from and may make such order, decision, or determination as ought to be made, and to that end shall have the powers of the Zoning Inspector from whom the appeal is taken.

The concurring vote of three (3) members of the Board shall be necessary to reverse any order, decision, or determination of the Zoning Inspector, or to decide in favor of the applicant on any matter upon which it is required to pass under this Resolution or to effect any variation in the application of this Resolution. The Board shall not grant an appeal or variance to allow a use not permissible under the

terms of this Resolution in the district involved, or any use expressly or by implication prohibited by the terms of this Resolution in said district. For the purpose of this Resolution, the Board has the following specific responsibilities:

- A. Hear and decide appeals where it is alleged there is an error in any order, requirement, decision or determination made by the Zoning Inspector, in accordance with Article VII of this Resolution.
- B. Authorize such variances from the terms of this Resolution as will not be contrary to the public interest, where, owing to special conditions of the land, a literal enforcement of this Resolution will result in unnecessary hardship in accordance with the provisions of Article VIII of the Resolution.
- C. Interpret the boundaries of the Official Zoning Map, in accordance with the provisions of this Resolution.
- D. Permit conditional uses as specified in the Official Schedule of District Regulations and under the conditions specified in Article IX of this Resolution, and such additional safeguards as will uphold the intent of the Resolution.
- E. Authorize the substitution or extension of nonconforming uses, as specified in Article V of this Resolution.
- F. Authorize extensions of time for completion of work specified in Zoning Certificate, in accordance with Section 4.06 of this Resolution
- G. Declare zoning permits void, pursuant to Section 4.09 of this Resolution.

Section 3.04 Powers of Zoning Inspector, Board of Zoning Appeals, and Township Trustees on Matters of Appeal

It is the intent of this Resolution that all questions of interpretation and enforcement shall first be presented to the Zoning Inspector. Such questions shall be presented to the Board of Zoning Appeals only on appeal from the decision of the Zoning Inspector, and recourse from the decisions of the Board of Zoning Appeals shall be only to the courts as provided by law. It is further the intent of this Resolution that the powers of the Board of Township Trustees in connection with this Resolution shall not include hearing and deciding questions of interpretation and enforcement that may arise. The Board of Township Trustees shall not have the authority to override the decisions of the Board of Zoning Appeals and/or the Zoning Inspector on matters of appeal or variance. Nonetheless, nothing in this Resolution shall be interpreted to prevent any official of the Township from appealing a decision of the Board of Zoning Appeals to the courts pursuant to Chapters 2505 and 2506 of the Ohio Revised Code.

ARTICLE IV

ENFORCEMENT AND PENALTY

Section 4.01 Zoning Certificate Required

No building, or other structure, shall hereafter be located, placed, installed, erected, constructed, re-constructed, enlarged, changed, or structurally altered nor shall any work be started upon the same, nor shall any use of land be commenced until a zoning certificate for the same has been issued by the Zoning Inspector, which zoning certificate shall state that the proposed building, or other structure, and/or use comply with all the provisions of this Resolution.

Section 4.02 Application for Zoning Certificate

Three (3) copies of an application for a zoning certificate shall be signed by the owner and applicant, if not the owner, attesting to the truth and exactness of all information supplied on the application. Each application shall clearly state that the permit shall expire and shall be revoked if work has not begun within one hundred eighty (180) days, and substantially completed within eighteen (18) months. At a minimum, the application shall contain the following information:

- A. Name, address, and telephone number of the owner and, if applicable, the applicant.
- B. Legal description of property, as recorded in Pickaway County Recorder's office.
- C. Existing use.
- D. Proposed use.
- E. Zoning district in which property is presently located.
- F. Plans in triplicate, drawn to scale, showing the actual dimensions and shape of the lot to be built upon, the exact dimensions and location of existing buildings of the lot, if any, and the location and dimensions of the proposed building(s) or alteration.
- G. Height of proposed buildings from the average grade.
- H. Number and dimensions of existing and proposed off-street parking or loading spaces.
- I. Number of proposed dwelling units.
- J. An approval by the Pickaway County Health Department of the proposed method of water supply and for disposal of sanitary wastes prior to approval by the Zoning Inspector.

- K. Such other material as may be requested by the Zoning Inspector to determine conformance with the provisions of this Resolution.
- L. A fee as established by the Board of Township Trustees.

Where complete and accurate information is not readily available from existing records, the Zoning Inspector may require the applicant to furnish a survey of the lot by a registered surveyor. In particular cases, the Zoning Inspector may reduce the submittal requirements for an application, when the proposed action warrants.

Section 4.03 Approval of Zoning Certificates

Within a reasonable period of time after the receipt, the application shall be either approved or disapproved by the Zoning Inspector, in conformance with the provisions of this Resolution, unless the provisions of Section 4.04 are applicable. Zoning certificates issued on the basis of plans and applications approved by the Zoning Inspector shall authorize only the use and arrangement as set forth in such approved plans and application(s). All zoning certificates shall be conditional upon the commencement of work within one hundred eighty (180) days. One (1) copy of the application shall be returned to the applicant by the Zoning Inspector after such copy is marked as either approved or disapproved and attested to same by the signature of the Zoning Inspector (or his/her designated agent) on such copy. In the case of disapproval, the Zoning Inspector shall state on the returned plans the specific reasons for disapproval. Two (2) copies of plans, similarly marked, shall be retained by the Zoning Inspector. One (1) copy retained by the Zoning Inspector shall be forwarded to the County Auditor upon issuance of a certificate of zoning compliance along with one (1) copy of the application. The Zoning Inspector shall issue a placard, to be posted in a conspicuous place on the property in question, attesting to the fact that the use or alteration is in conformance with the provisions of this Resolution.

Section 4.04 Submit to Director of Dept. of Transportation

Before any zoning certificate is issued affecting any land within 300 feet of the centerline of a proposed new highway or a highway for which changes are proposed as described in the certification to local officials by the Director of the Department of Transportation or any land within a radius of 500 feet from the point of intersection of said centerline with any public road or highway, the Zoning Inspector shall give notice, by registered or certified mail, to the Director of the Department of Transportation. The Zoning Inspector shall not issue a zoning certificate for 120 days from the date the notice is delivered to the Director of the Department of Transportation. If the Director of the Department of Transportation notifies the Zoning Inspector that the Director will proceed to acquire the land needed, then the Zoning

Inspector shall refuse to issue the Zoning Certificate. If the Director of the Department of Transportation notifies the Zoning Inspector that acquisition at this time is not in the public interest or if notification of action is not received by the Zoning Inspector, the Zoning Inspector shall, if the application is in conformance with all provision of this Resolution, issue the zoning certificate.

Section 4.05 Record of Zoning Certificates

A record of all zoning certificates shall be kept on file in the Office of the Zoning Inspector, or his designated agent, and copies shall be furnished upon request to any persons having proprietary or tenancy interest in the building or land affected. If, prior to completion of the work authorized under an issued zoning certificate, the property for which the certificate was issued is transferred; the applicant to whom the certificate was issued shall notify the Zoning Inspector of the new owner of such property.

Section 4.06 Expiration of Zoning Certificates

If the work described in any zoning certificate has not begun within one hundred eighty (180) days from the date of issuance thereof or has not been completed within eighteen (18) months from the date of issuance thereof, said certificate shall expire; it shall be revoked by the Zoning Inspector and written notice thereof shall be given to the persons affected, together with notice that further work as described in the expired permit shall not proceed unless and until a new zoning certificate has been obtained or extension granted by the Board of Zoning Appeals.

Section 4.07 Certificate of Zoning Compliance

It shall be unlawful to use or occupy, or permit the use or occupancy of any building or premises, or both, or part thereof hereafter created, erected, changed, converted, or wholly or partly altered or enlarged in its use or structure until a certificate of zoning compliance shall have been issued therefore by the Zoning Inspector stating that the proposed use of the building or land, as completed, conforms to the requirements of this Resolution. Such certificate of zoning compliance may be processed as an indication of final approval on the zoning certificate

Section 4.08 Schedule of Fees, Charges and Expenses

The Board of Township Trustees shall establish, by separate Resolution, a schedule of fees, charges, and expenses and a collection procedure for zoning permits, certificates of zoning compliance, appeals, conditional uses, variances, amendments and other matters pertaining to this Resolution. The schedule of fees shall be retained by the Zoning Inspector and posted in the Township offices and may be altered or amended only by the Board of

Township Trustees. Until all applicable fees, charges, and expenses have been paid in full, no action shall be taken on any application.

Section 4.09 Void Zoning Certificate

A zoning certificate shall be void if any of the following conditions exist:

- A. The zoning certificate was issued contrary to the provisions of this Resolution by the Zoning Inspector.
- B. The zoning certificate was issued based upon a false statement by the applicant.

When a zoning certificate has been declared void for any of the above reasons by the Board of Zoning Appeals pursuant to this Section, written notice of its revocation shall be given by certified mail to the applicant and sent to the address as it appears on the application. Such notices shall also include a statement that all work upon or use of the building, structure or land cease unless, and until, a new zoning certificate has been issued.

Section 4.10 Violation and Penalty

4.10.01 Construction and Use to be as provided in Applications, Plans, Permits, and Certificates
Zoning certificates or certificates of zoning compliance issued on the basis of plans and applications approved by the Zoning Inspector authorize only the use and arrangement set forth in such approved plans and applications or amendments thereto. Any use, arrangement, or construction not in conformance with that authorized shall be deemed a violation of this Resolution and punishable per Section 4.10.03.

4.10.02 Complaints Regarding Violations
Whenever a violation of this Resolution occurs, or is alleged to have occurred, any person may file a written complaint. Such complaint shall state fully the causes and basis thereof and shall be filed with the Zoning Inspector. The Zoning Inspector shall record properly such complaint, immediately investigate and take such appropriate action thereon as may be necessary and provided for by this Resolution.

4.10.03 Penalties for Violation
Violation of the provisions of this Resolution or failure to comply with any of its requirements (including violations of conditions and safeguards established in various sections of this Resolution) shall constitute a misdemeanor. Any person who violates this Resolution or fails to comply with any of its requirements shall upon conviction thereof, be fined not more than \$500 for each offense and, in addition, shall pay all costs and expenses involved in the case. Each day such violation continues shall be considered a separate offense. The owner or tenant of any building, structure, premises, or part thereof, and any architect, builder, contractor, agent, or other persons, who commits, participates in, assists in, or maintains such violation may each be

found guilty of a separate offense and suffer the penalties herein provided. Nothing herein contained shall prevent the Township, the County Prosecutor or any adjacent property owner from taking such other lawful action as is necessary to prevent or remedy any violations.

ARTICLE V

NONCONFORMING USES

Section 5.01 Intent

Within the districts established by this Resolution or amendments that may later be adopted, there exist lots, uses of land, structures, uses of structures and uses of structures and land in combination which were lawful before this Resolution was passed or amended, but which would be prohibited, regulated, or restricted under the terms of this Resolution or future amendment. It is the intent of this Resolution to permit these non-conformities to continue until they are removed, but not to encourage their survival. It is further the intent of this Resolution that nonconformities shall not be enlarged, expanded or extended, nor used as grounds for adding other structures or uses prohibited elsewhere in the same district except as may otherwise be permitted in this Resolution. Non-conformities are declared by this Resolution to be incompatible with permitted uses in the districts in which such use is located. After passage of this Resolution a non-conforming use of a structure, a non-conforming use of land, or a non-conforming use of a structure and land in combination shall not be extended or enlarged by attaching to a building or premises additional signs intended to be seen from off the premises, or by the addition of other uses of a nature which would be generally prohibited in the district in which such use is located. To avoid undue hardship, nothing in this Resolution shall be deemed to require a change in the plans, construction, or designated use of any building on which actual construction was lawfully begun prior to the effective date of adoption or amendment of this Resolution and upon which actual construction has been diligently pursued. "Actual construction" is hereby defined to include the placing of construction materials in permanent position and fastening such materials in a permanent manner. Where demolition or removal of an existing building has been substantially begun preparatory to rebuilding, such demolition or removal shall be deemed to be actual construction, provided that the work shall be carried out diligently.

Section 5.02 Single Non-Conforming Lots of Record

In any district in which single family dwellings are permitted, a single-family dwelling and customary accessory buildings may be erected on any single lot of record at the effective date of adoption or amendment of this Resolution, notwithstanding limitations imposed by other provisions of this Resolution. This provision shall apply even though such lot fails to meet the requirements for area or width, or both, that are generally applicable in the district, provided that yard dimensions and requirements other than those applying to area or width, or both, of the lot shall conform to the regulations for the district in which such lot is located. Variances of requirements of this

Resolution other than lot area or lot width shall be obtained only through action of the Board of Zoning Appeals.

Section 5.03 Non-Conforming Uses of Land

Where, at the time of adoption or amendment of this Resolution, lawful uses of land exist which would not be permitted by the regulations imposed by this Resolution, uses may continue so long as they remain lawful, provided:

- A. No such non-conforming uses shall be enlarged or increased, nor extended to occupy a greater area of land than was occupied at the effective date of adoption or amendment of this Resolution.
- B. No such non-conforming uses shall be moved in whole or in part to any portion of the lot or parcel other than that occupied by such uses at the effective date of adoption or amendment of this Resolution.
- C. If any such non-conforming uses of land are voluntarily discontinued or abandoned for more than two (2) years, any subsequent use of such land shall conform to the regulations specified by this Resolution for the district in which such land is located.
- D. No additional structure not conforming to the requirements of this Resolution shall be erected in connection with such non-conforming use of land.

Section 5.04 Non-Conforming Structures

Where a lawful structure exists at the effective date of adoption or amendment of this Resolution that could not be built under the terms of this Resolution by reason of restrictions on area, lot coverage, height, yards, location on the lot, or other requirements concerning the structure, such structure may be continued so long as it remains otherwise lawful, subject to the following provisions:

- A. No such non-conforming structure may be moved, extended, enlarged or structurally altered in a way which increases its non-conformity.
- B. Any non-conforming structure or non-conforming portion of a structure which is removed, partially removed, damaged, destroyed or partially destroyed by any means by sixty percent (60%) or less of its fair market value at the time of such removal, damage or destruction may be restored to its prior condition and the same use or occupancy continued or resumed, provided that the total cost of such restoration does not exceed sixty percent

(60%) of its then fair market value; and provided further that such restoration is started within nine (9) months after such removal, damage or destruction and that construction is completed within eighteen (18) months after such removal, damage or destruction.

- C. Any non-conforming structure or non-conforming portion of a structure which is removed, partially removed, damaged, destroyed or partially destroyed by any means by more than sixty percent (60%) of its then fair market value shall not be repaired or reconstructed except in conformity with the provisions of this Resolution unless a variance is obtained through action of the Board of Zoning Appeals.
- D. Should any non-conforming structure be moved for any reason for any distance whatever, it shall thereafter conform to the regulations for the district in which it is located after it is moved.

Section 5.05 Non-Conforming Uses of Structures or of Structures and Land in Combination

If a lawful use involving individual structures, or a structure and land in combination, exists at the effective date of adoption or amendment of this Resolution that would not be allowed in the district under the terms of this Resolution, the lawful use may be continued so long as it remains otherwise lawful, subject to the following provisions:

- A. No existing structure devoted to or housing a non-conforming use shall be enlarged, extended, constructed, reconstructed, moved, or structurally altered except in changing the use of the structure to a use permitted in the district it is located.
- B. Any non-conforming use may be extended throughout parts of a building which were manifestly arranged or designed for such use at time of adoption or amendment of this Resolution, but no such use shall be extended to occupy any land outside such building that was not used for such non-conforming use at the time of adoption or amendment of this Resolution.
- C. If no structural alterations are made, any non-conforming use of a structure or structure and land in combination, may, upon application to and approval by the Board of Zoning Appeals as a Conditional Use, be changed to another non-conforming use provided that in addition to any other criteria, the Board of Zoning Appeals finds after consideration of the nature, predominate character, and intensity of the proposed use and the size, dimensional requirements, and other regulatory characteristics of the proposed use, that the proposed use is equally or more appropriate to the district than the existing non-conforming use and that the size, dimensional

requirements, traffic, signage needs, parking requirements and other regulatory characteristics are not greater than the existing nonconforming use. The Board of Zoning Appeals may require appropriate conditions and safeguards in accordance with other provisions of this Resolution.

- D. The use of any structure or structure and land in combination, in or on which a non-conforming use is superseded by a permitted use, shall thereafter conform to the regulations for the district, and the non-conforming use may not thereafter be resumed.
- E. When a non-conforming use of a structure, or structure and land in combination, is voluntarily discontinued or abandoned for more than two (2) years, the structure, or structure and land in combination, shall not thereafter be used except in conformity with the regulations of the district in which it is located.
- F. When a structure and land in combination is devoted to or houses a nonconforming use, the removal, damage or destruction of the structure to the extent of more than sixty percent (60%) of its fair market value at the time of such removal, damage or destruction shall eliminate the non-conforming use of such structure or structure and land.

Section 5.06 Repairs and Maintenance

On any non-conforming structure or portion of a structure containing a nonconforming use, work may be done on ordinary repairs, or on repair or replacement of non-bearing walls, fixtures, wiring, or plumbing, provided that the cubic content existing when it became non-conforming shall not be increased. Nothing in this Section shall be deemed to prevent the strengthening or restoring to a safe condition of any building or part thereof declared to be unsafe by any official charged with protecting the public safety, upon order of such official.

ARTICLE VI

DISTRICT CHANGES AND AMENDMENTS

Section 6.01 Intent

This Article describes the procedures to be followed for amendment of the Zoning Resolution. If and to the extent that the provisions of this Article are inconsistent with the provisions of Section 519.12 of the Ohio Revised Code, as may be subsequently amended, the provisions of the Ohio Revised Code shall govern.

Section 6.02 Initiation of Zoning Amendments

Amendments to this Resolution may be initiated in one of the following ways:

- A. By the passage of a resolution by the Board of Township Trustees.
- B. By the adoption of a motion by the Township Zoning Commission.
- C. By the filing of an application by at least one (1) owner or lessee of property, or his designated agent, within the area proposed or affected by the said amendment.

Section 6.03 Contents of Application

Fifteen (15) signed copies of an application for amendment shall be submitted by the applicant to the Zoning Inspector and shall contain, at a minimum, the following information:

- A. Name, address, and phone number of the owner and applicant. The owner shall either sign the application or the application shall be accompanied by a notarized written statement, signed by the owner, authorizing the applicant to process the application.
- B. Proposed amendment to the text or legal description of property affected.
- C. Present use and district.
- D. Proposed use and district.
- E. A map drawn to scale showing property lines, existing structures, streets, existing and proposed zoning, and such other items as the Zoning Inspector may require.
- F. Legal description of the property and, if available, the street address.
- G. Contents of application to include a survey map prepared by a registered surveyor if only a portion of an existing

parcel is being requested to be rezoned. If survey map is 5 years old or older, all original survey pins must be located for survey to be considered valid. If survey pins cannot be located, then a new survey must be done.

- H. A preliminary survey plan prepared by a registered surveyor and drawn to scale, showing the following:
 - 1. The approximate number of lots intended to be created as well as the approximate lot dimensions and acreage if property is to be subdivided;
 - 2. The anticipated layout of the lots and driveways, as well as existing and anticipated streets;
 - 3. The location of existing natural features such as drainage courses, woods and waterways;
 - 4. Method for proposed provision of water and sewer services;
 - 5. In every case where the lot is not served and is not proposed to be served with public water supply and/or the disposal of sanitary wastes by means of public sewers, the application shall be accompanied by a Certificate of Approval by the Health Officer of Pickaway County of the proposed means of water supply and/or disposal of sanitary wastes.
- I. A narrative statement of the relationship of the proposed amendment to the criteria set forth in Section 6.09 and the reasons and/or justifications for the proposed amendment.
- J. A list of the names of all property owners within, contiguous to, directly across the street from, and within 200 feet of the parcel(s) proposed to be rezoned and their mailing addresses as appearing on the Pickaway County Auditor's current tax list.
- K. A statement as to how the proposed amendment will impact adjacent and proximate properties.
- L. Any other information as may be requested by the Zoning Inspector to determine conformance with and provide for enforcement of this Zoning Resolution.
- M. A fee as established by the Board of Township Trustees.

Upon receipt of the application, the Zoning Inspector shall review it for completeness. If the above requirements are met, the Zoning Inspector shall transmit the application to the Zoning Commission. The date of such transmittal shall be considered the date of filing. If the application is incomplete, the Zoning Inspector shall return it to the applicant with a listing of deficiencies.

Section 6.04 Submission to County Planning Commission

Within five (5) days after the adoption of a motion by the Zoning Commission, transmittal of a resolution by the Board of Trustees or the filing

of an application pursuant to Section 6.03 above, the Zoning Commission shall transmit a copy of such motion, resolution or application, together with the text and map pertaining to the case in question, to the Pickaway County Planning Commission. The Pickaway County Planning Commission shall recommend the approval or denial of the proposed amendment, or some modification thereof, and shall submit such recommendation to the Township Zoning Commission. Such recommendation shall be considered at the public hearing held by the Zoning Commission, pursuant to Section 6.05 below.

Section 6.05 Public Hearing by Zoning Commission

6.05.01 Date of Public Hearing

The Zoning Commission shall schedule a public hearing after adoption of their motion, transmittal of a resolution from the Board of Township Trustees, or the filing of an application pursuant to Section 6.03 above. Said hearing shall be held not less than twenty (20) nor more than forty (40) days from the date of adoption of such motion, transmittal of such resolution, or filing of such application.

6.05.02 Notice of Public Hearing in Newspaper

Before holding the public hearing as required, notice of such hearing shall be given by the Township Zoning Commission in at least one (1) newspaper of general circulation in the Township at least ten (10) days before the date of such hearing. The notice shall contain such information as may be required by applicable law.

6.05.03 Notice to Property Owners

If the proposed amendment intends to rezone or redistrict parcels of land, written notice of such hearing shall be mailed by the Zoning Commission, by first class mail, at least ten (10) days before the date of the hearing to all owners of property within, contiguous to, directly across the street from and within 200 feet of such area proposed to be rezoned or redistricted. Such notices shall be mailed to the addresses of the owners appearing on the Pickaway County Auditor's current tax list, as provided by the applicant in Section 6.03 (J) above. The failure to deliver such notices shall not invalidate any such amendment. The notices shall contain the same information as required of notices published in newspapers as specified in Section 6.05.02 above.

Section 6.06 Recommendation by Zoning Commission

Within thirty (30) days after the hearing required in Section 6.05 above, the Zoning Commission shall recommend to the Board of Township Trustees that the amendment be granted as requested, or it may recommend a modification of the amendment requested, or it may recommend that the amendment be denied.

Section 6.07 Public Hearing by Board of Township Trustees

Within thirty (30) days from receipt of the recommendation of the Zoning Commission, the Board of Township Trustees shall hold a public hearing. Notice of hearing by publication shall be as specified in Section 6.05.02 above.

Section 6.08 Action by the Board of Township Trustees

Within twenty (20) days after the public hearing required in Section 6.07 above, the Board of Township Trustees shall either adopt or deny the recommendation of the Zoning Commission, or may adopt some modification thereof. In the event the Board of Township Trustees denies or modifies the recommendation of the Zoning Commission, a majority vote of the Board of Township Trustees is required.

If a proposed amendment initiated by application is denied by the Board of Township Trustees, it may be resubmitted following the procedures as specified in Sections 6.02 through 6.07 above, at any time after one (1) year from the date action to deny was taken by the Board of Township Trustees.

Section 6.09 Criteria

In reviewing the proposed amendment and arriving at its decision, the Board of Township Trustees shall consider all relevant factors including, without limitation, the following:

- A. Compatibility of the proposed amendment with the zoning and use of adjacent land, and with land use or comprehensive plans adopted by the Township
- B. The effect of the adoption of the proposed amendment on motor vehicle access, traffic flow, storm drainage and public infrastructure in the area.
- C. The effect of the adoption of the proposed amendment upon the overall public health, safety and general welfare of the adjacent properties and other residents of the Township.

Section 6.10 Effective Date and Referendum

Such amendment adopted by the Board of Trustees shall become effective thirty (30) days after the date of adoption unless, within that thirty (30) days, there is presented to the Board of Trustees a petition, signed by a number of qualified voters residing in the unincorporated area of the Township or part thereof included in the zoning plan, equal to eight percent (8%) of the total

vote cast for all candidates for Governor in such area at the most recent election in which a Governor was elected, requesting the Township Trustees to submit the proposed amendment to the electors of such area, for approval or rejection, at the next primary or general election.

No amendment for which such referendum vote has been requested shall be put into effect unless a majority of the votes cast on the issue is in favor of the amendment. Upon certification by the Board of Elections that the amendment has been approved by the voters, it shall take effect immediately.

Section 6.11 Incorporation onto Zoning Map

If an amendment adopted by the Township Trustees or approved by referendum pertains to a change on the Official Zoning Map, such change may be incorporated onto the Map by reference to the Resolution Number and the date of adoption.

ARTICLE VII

APPEALS

Section 7.01 Appeals

Any official action of the Zoning Inspector may be appealed to the Board of Zoning Appeals by any person aggrieved or by any officer of the Township affected by the decision of the Zoning Inspector. The procedures to be followed shall be as specified in Sections 519.14 through 519.15 of the Ohio Revised Code, as may be amended.

Section 7.02 Notice of Appeal

An appeal to the Board of Zoning Appeals shall be taken within twenty (20) days after the date of the decision, by filing, with the Zoning Inspector and the Board of Zoning Appeals, a written notice of appeal, signed by the appellant, specifying the grounds of the appeal. A copy of the action by the Zoning Inspector shall be attached to the notice of appeal. The Zoning Inspector shall transmit to the Board of Zoning Appeals all the papers constituting the record upon which the action appealed from was taken.

Section 7.03 Action by the Board of Zoning Appeals

Upon receipt of the notice of appeal, the Board of Zoning Appeals shall fix a reasonable time for the hearing of the appeal, give ten (10) days notice in writing to parties in interest, give notice of such public hearing by one (1) publication in one (1) or more newspapers of general circulation in Pickaway County at least ten (10) days before the date of such hearing, and decide the appeal within a reasonable time after it is submitted. Upon the hearing, any person may appear in person or by attorney. Parties in interest is defined as the owner of the property in question and all owners of property contiguous to, directly across the street from, and within 200 feet of the property in question, all as appearing on the Pickaway County Auditor's current tax list. The Appellant shall furnish these owners' names and mailing addresses (as they appear on the Pickaway County Auditor's current tax list) to the Zoning Inspector at the time of filing the notice of appeal.

ARTICLE VIII

VARIANCES

Section 8.01 Powers of the Board of Zoning Appeals

The Board of Zoning Appeals shall have the power to authorize, in specific cases, such variances from the provisions or requirements of the Resolution as will not be contrary to the public interest where, owing to special conditions a literal enforcement of the provisions of this Resolution would result in unnecessary hardship.

Under no circumstance shall the Board of Zoning Appeals grant a variance to allow a use not permissible under the terms of this Resolution in the district involved or any use expressly or by implication prohibited by the terms of this Resolution in said district.

Section 8.02 Application for Variance

Any owner, or his/her agent, may request a variance by filing ten (10) complete copies of a provided application form with the Zoning Inspector. The Zoning Inspector shall forward these copies of the application to the Secretary of the Board of Zoning Appeals.

The application for a variance shall contain the following information:

- A. Name, address, and phone number of the owner and applicant and signed by the owner.
- B. Address and legal description of the subject property as recorded in Pickaway County Recorder's office.
- C. A plot plan, drawn to an appropriate scale, showing the boundaries and dimensions of the lot and any existing or proposed building.
- D. The names and addresses of all property owners within 200 feet of, contiguous to and directly across the street from the property, as appearing on the Pickaway County Auditor's current tax list.
- E. Each application for a variance shall refer to the specific provisions of this Resolution which apply.
- F. A narrative statement explaining the following:
 1. The nature and description of the variance sought.
 2. Details of the variance that is applied for and the grounds on which it is claimed that the variance should be granted.
 3. The specific reasons why the variance is justified, according to Section 8.04 below.

- G. A fee established by the Board of Trustees.
- H. Such other information as may be requested by the Board of Zoning Appeals.

Section 8.03 Public Hearing by the Board

Upon receipt of the variance application, the Board of Zoning Appeals shall fix a reasonable time for the hearing of the variance, give ten (10) days written notice to the parties in interest, give notice of such hearing by one (1) publication in one (1) or more newspapers of general circulation in the Township at least ten (10) days before the date of said hearing and render a decision on the variance within a reasonable period of time following the conclusion of the hearing. The notice shall set forth the time and place of the public hearing and the nature of the proposed variance. Parties in interest is defined as the owner of the property in question and all owners of property contiguous to, directly across the street from, and within 200 feet of the property in question, all as appearing on the Pickaway County Auditor’s current tax list.

Section 8.04 Action by Board of Zoning Appeals

The Board of Zoning Appeals shall approve, disapprove, or approve with supplementary conditions the request for variance. In granting any variance, the Board of Zoning Appeals may prescribe appropriate and reasonable conditions, including, without limitation, those necessary to ensure compliance with the terms under which the variance was granted. Violation of the conditions and/or safeguards, when made a part of the terms under which the variance is granted, shall be deemed a violation of this Resolution under Section 4.10 of this Resolution.

The Board of Zoning Appeals shall transmit a written copy of its decision and findings to the Zoning Inspector who shall forward such copy to the applicant. If the request for a variance is denied, the applicant may seek relief through the Court of Common Pleas.

8.04.01 Approval of a Variance

Except as otherwise provided for area variances in Section 8.04.03, below, the Board of Zoning Appeals shall only approve a variance or modification thereof if it determines:

- A. That such variance or modification will not be contrary to the public interest; and
- B. That owing to special conditions, a literal enforcement of this Zoning Resolution will result in unnecessary hardship; and

- C. That the approval of such variance or modification thereof is consistent with the spirit of this Zoning Resolution, and substantial justice shall be done thereby.

8.04.02 Factors to be considered

In making its decision under Section 8.04.01, above, the Board of Zoning Appeals shall consider all relevant factors including, but not limited to, the following:

- A. That special conditions and circumstances exist which are peculiar to the land, structure, or building involved and which are not applicable to other lands, structures, or buildings in the same district; and
- B. That a literal interpretation of the provisions of this Resolution would deprive the applicant of rights commonly enjoyed by other properties in the same district under the terms of this Resolution; and
- C. That the special conditions and circumstances do not result from the actions of the applicant; and
- D. That granting the variance requested will not confer on the applicant the same effect as rezoning to another zoning district classification; and
- E. That granting the requested variance will conform to the Scioto Township Comprehensive Plan and the spirit and intent of the Scioto Township Zoning Resolution; and
- F. That the requested variance is the minimum variance necessary to accomplish the purpose of the request; and
- G. That granting the variance will not adversely affect the health or safety of persons residing or working in the vicinity of the proposed development, be materially detrimental to persons or property in such vicinity, or injurious to private property or public improvements in the vicinity.

8.04.03 Area Variance

The Board of Zoning Appeals shall not grant an area variance unless the property owner has encountered practical difficulties in the use of such owner's property. The Board of Zoning Appeals shall consider all relevant factors in determining whether the applicant has encountered practical difficulties in the use of such property including, but not limited to:

- A. Whether the property in question will yield a reasonable return or whether there can be any beneficial use of the property without the variance.
- B. Whether the variance is substantial.
- C. Whether the essential character of the neighborhood would be substantially altered, or whether adjoining properties would suffer a substantial detriment as a result of the variance.
- D. Whether the variance would adversely affect the delivery of governmental services (e.g., water, sewer, garbage).
- E. Whether the property owner purchased the property with knowledge of the zoning restriction.

- F. Whether the property owner's predicament feasibly can be obviated through some method other than a variance.
- G. Whether the spirit and intent behind the zoning requirement would be observed and substantial justice done by granting the variance.

ARTICLE IX

CONDITIONAL USES

Section 9.01 Authority and Purpose

Under some unusual circumstances, a use of property which typically affects an area more intensely than those uses permitted in the zoning district in which it is located may, nonetheless, be desirable and compatible with permitted uses, if that use is properly controlled and regulated. Such uses are listed as “conditional uses” within the respective zoning districts.

The Board of Zoning Appeals may grant conditional approval for a conditional use of the land, buildings, or other structures and may allow such a use to be established where unusual circumstances exist and where the specific conditional use is provided for within the applicable zoning district and where the conditional use will be consistent with the general purpose and intent of this Zoning Resolution.

Section 9.02 Application for Conditional Use

Any owner of property may request to use such property for one of the conditional uses provided for by this Resolution in the zoning district in which the property is situated by filing ten (10) complete copies of a provided application form with the Zoning Inspector who shall forward these copies to the Secretary of the Board of Zoning Appeals. At a minimum the application shall contain the following information:

- A. Name, address, and phone number of the owner and applicant and signed by the owner.
- B. Address and legal description of the property as recorded in the Pickaway County Recorder's office.
- C. Present zoning district.
- D. Description of proposed conditional use.
- E. A plot plan, drawn to an appropriate scale, of the proposed site for the conditional use showing the location of all buildings, parking and loading area, traffic circulation, open spaces, landscaping, refuse, and service areas, utilities, signs, yards, and such other information as the Board may require to determine if the proposed conditional use meets the intent and requirements of this Resolution.
- F. A narrative statement evaluating the effects on adjoining property, the effect of such elements as noise, glare, odor, light, fumes and vibration on adjoining property, and a discussion of the general compatibility with adjacent and other properties in the district.

- G. The names and addresses of all property owners within 200 feet of, contiguous to and directly across the street from the property, as appearing on the Pickaway County Auditor's current tax list. The applicant shall also provide the addresses of all property within the above referenced boundaries.
- H. Such other information regarding the property, proposed use, or surrounding area as may be pertinent to the deliberations of the Board.
- I. A fee as established by the Board of Trustees.

Section 9.03 General Standards for Conditional Uses

The Board shall not approve a conditional use unless it shall, in each specific case, make specific findings of fact directly based on the particular evidence presented to it that support conclusions that such use at the proposed location shall meet all of the following requirements:

- A. Will be consistent with the general objectives, or with any specific objective or purpose, of this Zoning Resolution.
- B. Will be harmonious with the existing or intended character of the general vicinity and that such use will not change the essential character of the same area.
- C. Will be served adequately by essential public facilities and services such as highways, streets, police and fire protection, drainage structures, refuse disposal, water and sewers, and schools.
- D. Will not involve uses, activities, processes, materials, equipment and conditions of operation that will be detrimental to any persons, property, or the general welfare by reason of excessive production of traffic, noise, smoke, fumes, glare or odors.
- E. Will have vehicular approaches to the property which shall be so designated as not to create interference with traffic on surrounding public streets or roads.
- F. Will possess all approvals and/or licenses as required by state or local agencies.

Section 9.04 Supplementary Conditions

In granting any conditional use, the Board may prescribe appropriate conditions and safeguards in conformance with this Resolution. The Board of Zoning Appeals shall also have the authority to prescribe that as a condition of approval; the conditional use shall not be permanent but shall be personal to the applicant and shall not run with the land.

If such a condition is imposed, then the sale or conveyance of the land and/or structure whereon the conditional use was located and/or conducted shall result in the immediate termination of the conditional use, and any subsequent owner of such land and/or structure shall be required to file and obtain the approval of a new application for such conditional use. Violation of the conditions and/or safeguards, when made a part of the terms under which the conditional use is granted, shall be deemed a violation of this Resolution under Section 4.10 of this Resolution.

Section 9.05 Public Hearing by the Board of Zoning Appeals

The Board of Zoning Appeals shall hold a public hearing within a reasonable period of time following its receipt of the application specified in Section 9.02. The Board of Zoning Appeals shall give ten (10) days written notice to the parties in interest and give notice of such hearing by one (1) publication in one (1) or more newspapers of general circulation in the Township at least ten (10) days before the date of said hearing. The notice shall set forth the time and place of the public hearing and the nature of the proposed conditional use. Parties in interest is defined as the owner of the property in question and all owners of property contiguous to, directly across the street from, and within 200 feet of the property in question, all as appearing on the Pickaway County Auditor's current tax list.

Section 9.06 Action by the Board of Zoning Appeals

Within a reasonable period of time following the conclusion of the public hearing pursuant to Section 9.05, the Board shall approve, approve with supplementary conditions as specified in Section 9.04, or disapprove the application as presented. If the application is approved with supplementary conditions, the Board shall direct the Zoning Inspector to issue a zoning certificate listing the specific conditions listed by the Board for approval. If the application is disapproved, the applicant may seek relief through the Court of Common Pleas.

Section 9.07 Expiration and Revocation of Zoning Certificate Issued Under Conditional Use Provisions.

The approval of the zoning certificate issued in accordance with Section 9.06 shall become null and void if such use is not carried out within one (1) year after date of approval. The Board may revoke the zoning certificate upon written evidence by any resident or official of the Township of violation of the Zoning Resolution and/or written terms and conditions upon which approval was based.

ARTICLE X

(RESERVED FOR FUTURE USE)

PART THREE

ZONING DISTRICTS

ARTICLE XI

STANDARD ZONING DISTRICT REGULATIONS

Section 11.01 Regulations for the Use and Development of Land or Structures

Regulations pertaining to the use of land and/or structures and the physical development thereof within each of the zoning districts as established in Article XII, are hereby established and adopted.

Section 11.02 Rules of Application

11.02.01 Identification of Uses

Listed uses are to be defined by their customary name or identification, except as specifically defined or limited in this Resolution.

11.02.02 Permitted Uses

- A. Only a use designated as permitted shall be allowed as a matter of right in any zoning district and any use not so designated shall be prohibited.
- B. No more than one (1) permitted principal use shall exist on any one zoning lot.

11.02.03 Accessory Uses

An accessory use or structure is a subordinate use or structure clearly incidental and secondary to the principal permitted building or use, and located on the same lot with such principal building or use. Accessory uses or structures shall be allowed in accordance with the specific district regulations and the requirements of Article XXIX of this Resolution.

11.02.04 Conditional Uses

A use designated as a conditional use may, if approved by the Board of Zoning Appeals, be allowed in the zoning district where the designation occurs, when such use, its location, extent and method of development will not substantially alter the character of the vicinity or unduly interfere with or adversely impact the use of adjacent lots. To this end, the Board of Zoning Appeals may, in addition to the development standards for the specific district, set forth additional requirements as will render the conditional use compatible with existing and future use of adjacent lots in the vicinity, in accordance with Article IX of this Resolution.

11.02.05 Intentionally Left Blank

11.02.06 Development Standards

Development standards set forth in this Resolution shall be the minimum allowed for uses permitted in that district. If development standards are in conflict with requirements of any other lawfully adopted rule, regulation, or law, the most restrictive standard shall govern.

ARTICLE XII

ZONING DISTRICTS AND ZONING DISTRICT MAP

Section 12.01 Zoning Districts Established

The following zoning districts are hereby established for Scioto Township:

- AG - Agricultural Estate District*
- R-1 - Rural Residential District*
- R-2 - Suburban Residential District*
- R-3 - Urban Density Residential District*
- MH-R - Manufactured Home Residential District*
- SO - Suburban Office District*
- NC - Neighborhood Commercial District*
- GC - General Commercial District*

- PCRD - Planned Conservation Residential District*
- PURD - Planned Unit Residential Development*
- PB - Planned Business District*
- PI - Planned Industrial District*
- O-R - Orient Residential District*
- SU - Special Use District*

- FP - Flood Plain Overlay District*
- DCC - Darby Creek Conservation District*
- ANO - Airport Noise Overlay District*

Section 12.02 Official Zoning Map

The districts established in Section 12.01 of this Resolution are shown on the Official Zoning Map which, together with all notations, references, data, district boundaries and other explanatory information, is hereby adopted as a part of this Resolution. The Official Zoning Map shall be identified by the signatures of the Board of Township Trustees and the Fiscal Officer and shall be on file in the Township offices.

Section 12.03 Interpretation of Zoning District Boundaries

Except where referenced and noted on the Official Zoning Map by a designated line and/or dimensions, the district boundary lines are intended to follow property lines, lot lines, centerlines of streets, alleys, streams and/or railroads as they existed at the time of passage of this Resolution. The Zoning Inspector shall interpret the boundary lines from the Zoning Map. When and if the Zoning Inspector's interpretation of such boundary line is disputed, the final interpretation authority shall rest with the Board of Zoning Appeals.

ARTICLE XIII

(AG) AGRICULTURAL ESTATE DISTRICT

Section 13.01 Purpose

This district is established to encourage the continuance of agricultural uses, to preserve rural character, and to protect land areas possessing soils particularly well suited for agricultural activity from urban encroachment.

Section 13.02 Agricultural Uses Defined

“Agricultural use” means the same as stated in Section 519.01 of the Ohio Revised Code, as may be amended, to include farming; ranching; aquaculture; apiculture; horticulture; viticulture; animal husbandry, including but not limited to the care and raising of livestock, equine and fur-bearing animals; poultry husbandry and the production of poultry and poultry products; dairy production; the production of field crops, tobacco, fruits, vegetables, nursery stock, ornamental shrubs, ornamental trees, flowers, sod, or mushrooms; timber; pasturage; any combination of the foregoing; the processing, drying storage and marketing of agricultural products when those activities are conducted in conjunction with, but are secondary to, such husbandry or production.

Section 13.03 Permitted Uses

- A. Agricultural uses, along with customary agricultural buildings and structures incidental to the carrying out of the principal agricultural activity, and/or no more than one single-family detached dwelling, subject to the provisions of Section 13.02 above.
- B. One single-family detached dwellings.
- C. Limited home occupations, subject to the requirements of Section 29.02 of this Resolution.
- D. Projects specifically designed for watershed protection, conservation of water or soils for flood control.
- E. Child day care type B home.

Section 13.04 Accessory Uses

- A. Accessory buildings or structures customarily associated with single-family residential use, including detached garages or carports, tool or garden sheds, playhouses, swimming pools, and tennis courts and similar facilities for primary use by occupants of the principal use of the

property on which the facility is located, subject to the requirements of Article XXIX of this Resolution.

- B. Lakes or ponds for the primary use of the occupants of the principal residence, subject to the regulations of Section 29.06 of this Resolution.
- C. Farm markets (as defined in ORC 519.21). Roadside sales of agricultural products shall be permitted in this district, provided at least fifty (50%) percent of the gross income from the market is derived from the sale of produce raised on farms owned or operated by the market operator in a normal crop year.
 - 1. Buildings less than 144 square feet must be placed at least 15 feet outside the road right of way so as to safely allow for adequate customer off street parking. Seasonal farm markets may use grassed areas for parking. Permanent farm markets must be paved or graveled parking.
 - 2. For buildings larger than 144 square feet, off street parking must be provided at the ratio of one space for each 150 square feet of farm market. Seasonal parking may be grassed areas, but permanent parking must be graveled or paved and provided egress in accordance with the recommendation of the Pickaway County Engineer. Setbacks are the same as for any structure in this zoning district.

Section 13.05 Conditional Uses

- A. Public parks and/or nature preserves.
- B. Private landing fields for aircraft, subject to the following additional criteria.
 - 1. The applicant shall present sufficient evidence that the design and location of the facility satisfies all of the applicable requirements of the Federal Aviation Administration, and the Ohio Department of Transportation, Division of Aviation, and the County of Pickaway.
 - 2. The applicant shall provide sufficient information that all appropriate air rights have been secured for all runway paths.
 - 3. The location of buildings, hangers, or other structures shall meet or exceed the minimum setback requirements of the district in which the airport is located.
 - 4. The location and capacity of all off-street parking and loading areas and the location of vehicular access to public streets shall be approved by the Board of Zoning Appeals.
 - 5. The facility shall have water supply and wastewater disposal facilities approved by the Ohio EPA.
 - 6. Appropriate visual and noise screening of the hanger and terminal areas from existing surrounding development shall be provided.
 - 7. The facility shall be at least four hundred and fifty (450) feet from any existing residence or residential district.

8. The facility shall be for the personal use of the owner of the property and such owner's guests and commercial or industrial uses shall be prohibited.
9. Evidence shall be submitted to show the facility complies with all airport zoning regulations in effect.

C. Accessory Apartment (Granny flat) - An accessory apartment, as an independent dwelling unit, may be permitted, provided it meets the following conditions:

1. The apartment must be located in the principal structure (which includes attached garages or areas over attached garages) and there must be access to the apartment from the principal structure.
2. Maximum size of the apartment dwelling unit shall not exceed 816 Square feet.
3. The structure must maintain a single-family residential appearance which blends with the principal structure and the neighborhood. An architectural rendering and floor plan must be provided and approved by the Board of Zoning Appeals. Said plans shall include a landscape plan, which shall be followed as approved.
4. Public water and sewer must be provided, or the lot must be adequately sized for, and systems approved for water supply and wastewater disposal to serve both the principal residence and the accessory apartment. The Board of Health (or the OEPA, if applicable) shall approve the proposed provision of water and sewer.
5. Off street parking on a hard (i.e. pavement or gravel) all-weather surface must be provided, 2 spaces for the principal residence and 2 spaces for the accessory apartment, 9' x 18' per space. No one space shall block another. Garages may count as parking spaces.
6. Accessory apartment may be located on first or second floor.
7. All structures must meet the current edition of the CABO (now ICC) One and Two Family Dwelling Code and the Pickaway County Plumbing Code.
8. Property owner must live on site, and the accessory apartment must be subservient to principal use of property as a dwelling.
9. The accessory apartment shall be occupied only by a member of the family of the owner of the principal residence. Family means an individual(s) related to the owner of the property by blood, adoption or marriage.
10. There shall be not more than one (1) accessory apartment per principal structure.

D. Expanded Home Occupation as provided in Section 29.02 of this Resolution.

Section 13.06 Development Standards

13.06.01 Lot Area

For each principal permitted use, the lot area shall be not less than five (5) acres, or such size as determined by the Pickaway County Health Department, whichever is larger.

13.06.02 Minimum Lot Width

All lots shall have at least 300 feet of continuous frontage on a publicly dedicated, improved street or highway.

13.06.03 Minimum Front Yard Depth

Ninety (90) feet from the center line of any county or township road; 130 feet from the center line of any federal or state highway.

13.06.04 Minimum Side Yard Width

Twenty-five (25) feet on each side.

13.06.05 Minimum Rear Yard Depth

Eighty (80) feet.

13.06.06 Minimum Building Area

1,400 square feet of floor area shall be required for single-family dwellings having one (1) story; 1,800 square feet of floor area shall be required for single-family dwellings with one-and-one-half (1½) or more stories.

13.06.07 Maximum Principal Building Height

Forty-five (45) feet for buildings. Silos, windmills, or any other structure listed as an accessory use may exceed this height provided such structures maintain a distance equal to their height to any adjacent property or zoning district.

ARTICLE XIV

(R-1) RURAL RESIDENTIAL DISTRICT

Section 14.01 Purpose

This district is established to provide areas for large lot single family residential development reflecting very low density and a rural but non-farm lifestyle. Such development functions as a transitional area between agricultural and urban areas and is typically not served by public water or sewer systems.

Section 14.02 Permitted Uses

- A. One single-family detached dwellings.
- B. Limited home occupations, subject to the requirements of Section 29.02 of this Resolution.
- C. Projects specifically designed for watershed protection, conservation of water or soils for flood control.
- D. Child day care type B home.

Section 14.03 Accessory Uses

- A. Accessory buildings or structures customarily associated with single-family residential use, including detached garages or carports, tool or garden sheds, playhouses, swimming pools, tennis courts and similar facilities for primary use by occupants of the principal use of the property on which the facility is located, subject to the requirements of Article XXIX of this Resolution.
- B. Lakes or ponds for the primary use of the occupants of the principal residence, subject to the regulations of Section 29.06 of this Resolution.

Section 14.04 Conditional Uses

- A. Public parks and nature preserves.
- B. Accessory Apartment (Granny Flat), subject to the requirements of Section 13.05 C of this Resolution.
- C. Expanded home occupations as provided in Section 29.02 of this Resolution.

Section 14.05 Development Standards

14.05.01 Lot Area

For each principal permitted use, the lot area shall be not less than one (1) acre or more than five (5) acres in size. In all cases, such lot shall be of sufficient size to accommodate the provision of water and sanitary sewer facilities as determined by the Pickaway County Health Department or the applicable State of Ohio regulatory agency, whichever is applicable.

14.05.02 Minimum Lot Width

All lots shall have a lot depth-to-width ratio of not greater than 3.5:1. All lots shall have at least 150 feet continuous frontage on a publicly dedicated, improved street or highway.

14.05.03 Minimum Front Yard Depth

Ninety (90) feet from the center line of any county or township road; 130 feet from the center line of any federal or state highway.

14.05.04 Minimum Side Yard Width (Revised 6/3/2018)

Ten (10) feet on each side.

14.05.05 Minimum Rear Yard Depth

Eighty (80) feet.

14.05.06 Minimum Building Area

1,400 square feet of floor area shall be required for single-family dwellings having one (1) story; 1,800 square feet of floor area shall be required for single-family dwellings with one-and-one-half (1½) or more stories.

14.05.07 Maximum Principal Building Height

Forty-five (45) feet.

ARTICLE XV

(R-2) SUBURBAN RESIDENTIAL DISTRICT

Section 15.01 Purpose

This district is established to provide areas for single-family residential development at relatively low suburban densities. Such areas shall be served by centralized water and/or sewer systems.

Section 15.02 Permitted Uses

- A. One single-family detached dwellings.
- B. Limited home occupations, subject to the regulations of Section 29.02 of this Resolution.
- C. Public parks, playgrounds and play fields.
- D. Child day care type B home.

Section 15.03 Accessory Uses

Accessory buildings or structures customarily associated with single-family residential use, including detached garages or carports, tool or garden sheds, playhouses, swimming pools, tennis courts and similar facilities for primary use by occupants of the principal use of the property on which the facility is located, subject to the requirements of Article XXIX of this Resolution.

Section 15.04 Conditional Uses

- A. Accessory Apartment (Granny Flat), subject to the requirements of Section 13.05 C of this Resolution.
- B. Expanded home occupations as provided in Section 29.02 of this Resolution.
- C. Community parks, playgrounds and playfields which are incidental and adjacent to, and developed in conjunction with, a single-family residential development and which are designed and developed to exclusively serve the residents of the adjacent residential development.

Section 15.05 Development Standards

15.05.01 Minimum Lot Area
20,000 square feet.

15.05.02 Minimum Lot Width

For each principal use there shall be lot width of not less than 100 feet with continuous frontage on a publicly dedicated, improved street or highway. Minimum lot width on a curved street shall be 60 feet. In addition, lot width shall be sufficient to maintain a lot depth-to-lot width ratio of not greater than 3:1.

15.05.03 Minimum Front Yard Depth

130 feet from the center line of any state or federal highway; ninety (90) feet from the center line of any county or township road.

15.05.04 Minimum Side Yard Width

Twenty (20) feet on each side.

15.05.05 Minimum Rear Yard Depth

Fifty (50) feet.

15.05.06 Minimum Building Area

1,200 square feet of floor area shall be required for single-family dwellings having one (1) story; 1,600 square feet of floor area shall be required for single-family dwellings with one-and-one-half (1½) or more stories.

15.05.07 Maximum Building Height

Thirty-five (35) feet.

ARTICLE XVI

(R-3) URBAN DENSITY RESIDENTIAL DISTRICT

Section 16.01 Purpose

The R-3 District is established to accommodate a variety of housing types suited to the various life styles of individuals and families, including single and multiple-family residences. The objective is to provide for a diversity of housing opportunity and choice within Scioto Township. As a result of the higher residential densities, areas within the R-3 District shall be served by centralized water and sewer.

Section 16.02 Permitted Uses

- A. Single-family detached dwelling.
- B. Limited home occupations, subject to the requirements of Section 29.02 of this Resolution.
- C. Multiple family structures having two or more dwellings per structure
- D. Public parks.
- E. Child day care type B home.

Section 16.03 Accessory Uses

- A. Uses incidental and accessory to multiple-family dwellings and for exclusive use of their residents, to include common recreational facilities, community swimming pools, and offices for the rental and management of units therein.
- B. Temporary buildings for uses incidental to construction work, which shall be removed upon the completion or abandonment of construction work.

Section 16.04 Conditional Uses

- A. Nursery schools and day care centers, other than a child day care type B home.
- B. Expanded home occupations in conjunction with a one-family detached dwelling as provided in Section 29.02 of this Resolution.
- C. Community parks, playgrounds and playfields which are incidental and adjacent to, and developed in conjunction with, a single-family residential development and which are designed and developed to exclusively serve the residents of the adjacent residential development.

Section 16.05 Development Standards

16.05.01 Minimum Lot Area

15,000 square feet for single-family dwellings, 10,000 square feet per dwelling unit for two-family dwellings and 9,000 square feet per dwelling unit for all other multiple-family dwellings.

16.05.02 Minimum Lot Frontage

100 feet of continuous frontage on a publicly dedicated and improved street or highway.

16.05.03 Minimum Front Yard Depth

130 feet from the center line of any state or federal highway; ninety (90) feet from the center line of any county or township road.

16.05.04 Minimum Side Yard Width

Twenty (20) feet on each side.

16.05.05 Minimum Rear Yard Depth

Fifty (50) feet.

16.05.06 Maximum Building Height

Thirty-five (35) feet.

16.05.07 Trash and Garbage Control

For all uses other than single-family residences, all trash and garbage shall be stored in container systems which are located and enclosed so as to effectively screen them from view. The disposal of trash and maintenance of the area shall be the responsibility of the owner of the property.

16.05.08 Open/Play Area

Within each multiple family development, for each four (4) units, or portion thereof, there shall be provided an open space or play area of not less than 500 square feet in size. The design and configuration of such open area shall be submitted to and approved by the Zoning Commission at the time of the application for zoning into the R-3 District. Assurances shall be provided that such open area shall be maintained by the owner of the multiple-family complex.

ARTICLE XVII

(MH-R) MANUFACTURED HOME RESIDENTIAL DISTRICT

Section 17.01 Purpose

The Manufactured Home Residential (MH-R) District is established to provide areas for manufactured home communities in Scioto Township so as to provide a desirable residential environment, protected from adverse neighboring influences, with adequate access for vehicular traffic and circulation. These residential communities shall be developed and located so as not to promote excessive vehicular traffic on streets in adjoining neighborhoods, and shall provide overall desirability equivalent to that for other forms of residential development.

Section 17.02 Requirements Generally

Pursuant to Section 519.212 of the Ohio Revised Code, permanently sited manufactured homes and modular homes, as defined in Article II of this Resolution, shall be considered as permitted uses in any district that permits single-family dwellings. Mobile homes, as defined in Article II of this Resolution and/or Section 4501.01 of the Ohio Revised Code, and manufactured homes not qualifying as permanently sited manufactured homes shall not be considered as permitted or conditional uses in this or any other zoning district in Scioto Township.

Section 17.03 Permitted Uses

- A. Manufactured home communities, subject to approval of Development Plan and the standards of this district.
- B. Public parks.
- C. Child day care type B home.

Section 17.04 Accessory Uses

Uses and structures incidental and accessory to specified permitted uses to include common areas, community/recreational facilities and offices for rental and management of units therein.

Section 17.05 Conditional Use

- A. One-family detached dwellings, provided the lot complies with the standards of the R-1 District.
- B. Nursery schools and/or day care centers, other than a child day care type B home.

- C. Community parks, playgrounds and playfields which are incidental to and developed in conjunction with, an adjacent residential development and which are designed and developed to exclusively serve the residents of the adjacent residential development.

Section 17.06 Development Standards

The following standards for the arrangement and development of manufactured home subdivisions and/or communities in the MH-R District.

17.06.01 Water and Sewer

Any manufactured home subdivision or community shall be provided with a water and sanitary sewer distribution system, serving each individual home lot, which is connected to centralized water and sanitary sewage system. The design and construction of such distribution systems shall be approved by the Ohio Environmental Protection Agency.

17.06.02 Minimum Lot Area

- A. The minimum lot area for a manufactured home community shall be ten (10) acres. Individual manufactured home lots within such communities shall be not less than 4,000 square feet. The maximum gross density shall not exceed six (6) dwelling units per acre.
- B. For any other permitted use, the minimum lot area shall not be less than 10,000 square feet.

17.06.03 Minimum Lot Width

- A. The minimum lot width for any manufactured home community shall be not less than 300 feet. Frontage shall be provided on a publicly dedicated and improved street. The minimum lot width for any individual lot within such a community shall be not less than forty (40) feet.
- B. For any other permitted use, the minimum lot width shall be eighty (80) feet.

17.06.04 Minimum Front Yard

The minimum front yard depth for any manufactured home community shall be 130 feet from the center line of any state or federal highway; 90 feet from the center line of any county or township road.

17.06.05 Minimum Side Yard Width

- A. The minimum side yard width for any manufactured home community shall be not less than fifty (50) feet. The minimum side yard width for any individual lot within a

manufactured home community shall be not less than ten (10) feet on each side.

- B. For any other permitted use, the minimum side yard width shall be not less than ten (10) feet on each side.

17.06.06 Minimum Rear Yard Depth

- A. The minimum rear yard depth for any manufactured home community shall be no less than fifty (50) feet. The minimum rear yard depth for any individual lot within a manufactured home community shall be no less than ten (10) feet.
- B. For any other permitted use, the minimum rear yard depth shall be not less than forty (40) feet.

17.06.07 Minimum Lot Coverage

Detached dwelling units and their accessory buildings shall not occupy more than forty-five percent (45%) of the lot area of any individual lot within a manufactured home subdivision or community.

17.06.08 Required Open Space and Recreational Areas

At least twenty percent (20%) of the gross land area for any manufactured home community shall be reserved for common recreational areas and facilities, such as playgrounds, swimming pools, pedestrian paths, and similar facilities. Such recreational and open space facilities shall not be a part of streets and/or parking areas, and shall be closed to motorized traffic, except for service and emergency vehicles. Such areas shall be landscaped, improved and maintained by the owner of the development for the intended uses.

17.06.09 Off-Street Parking

For permitted and conditional uses, parking spaces shall be provided for two (2) vehicles for each dwelling unit. In manufactured home communities, parking spaces may be located on the same lot, or in specially provided common areas located no more than 600 feet from the dwelling which they serve, or some combination thereof. Required parking spaces shall not be on public or private streets within and on the perimeter of the community. Parking shall be so arranged that there is no maneuvering incidental to parking in the travel lane of streets.

17.06.10 Access

All manufactured home communities shall have direct access to a street or road designated of not less than a collector status on the Thoroughfare Plan for Pickaway County. Principal vehicular access points shall be designed to encourage smooth traffic flow. Merging and turnout lanes and/or traffic dividers shall be required where existing or anticipated traffic volumes indicate need. Minor streets shall not be connected with streets outside the district in such a way so as to encourage the use of those streets by substantial amounts of

through traffic. No individual lot within the community shall have direct vehicular access to a street bordering the development.

17.06.11 Streets and Street Layout

All streets providing access to the individual lots in a manufactured home community shall be dimensioned and improved in accordance with the standards and requirements of the Pickaway County Subdivision Regulations. The proposed layout of such streets shall be approved by the Zoning Commission. In making such determinations, the Commission may procure the assistance of an engineer or other professional. All costs associated with such approval shall be paid by the applicant.

17.06.12 Storm Drainage

All areas within a manufactured home community shall be graded and drained so as to minimize standing water and surface runoff. Open drainage ditches shall be prohibited. The proposed methods to address standing water and excessive surface runoff shall be submitted by the applicant and approved by the Pickaway County Engineer or his designated agent. All costs associated with such approvals shall be paid by the applicant.

17.06.13 Underground Utilities

Within any manufactured home community, all utility lines, including electricity, telephone, and cable television shall be located underground.

ARTICLE XVIII

(SO) SUBURBAN OFFICE DISTRICT

Section 18.01 Purpose

The SO District is intended to provide an opportunity for development of low-intensity office and related service uses which functionally and aesthetically blend with and complement the predominantly residential and rural characteristics of the Township. No unrelated retail trade is permitted in the SO District. Abutment on or suitable access to a major or minor arterial road is generally necessary for SO uses. The SO District can be used to provide a buffer between residential and commercial or industrial areas. Development standards to limit the intensity of SO uses are therefore provided to encourage smooth transitions between zones.

Section 18.02 Permitted Uses

- A. Professional Offices for physicians, dentists, other licensed health practitioners, attorneys, accountants, engineers, architects, and other similar professions.
- B. Administration and business office for insurance, real estate, data processing, advertising, business, professional or civil associations, and other similar management and/or service functions.
- C. Financial institutions and offices including banks, savings and loans, brokerage firms, credit institutions, and other similar financial and related services.
- D. Mortuaries, funeral homes and other similar services.

Section 18.03 Conditional Uses

- A. Drive-in facility, developed in association with a permitted use. In addition to the standards of Article IX, the following standards shall be met:
 - 1. The Board of Zoning Appeals may require that the applicant submit a traffic analysis and detailed plot plan performed by a registered professional engineer that demonstrates the proposed drive-in facility will not create traffic congestion or unsafe points of traffic conflict. All parking, ingress, egress and interior circulation shall be clearly marked with striping and/or curb barriers.
 - 2. The proposed drive-in facility and access drive shall conform to all building setback and other developmental standards and shall be screened by plantings or other appropriate methods when adjacent to residential areas.

- B. Personal services generally involving the care of the person, including barber shops, beauty shops, portrait photography, and similar services. No unrelated retail trade is permitted.
- C. Educational and research institutions which in appearance and land use functional characteristics are similar to permitted office uses.
- D. Single -family residential uses in association with and located within the same structure as a permitted principal use, provided that the residential portion of the lot is included with the permitted use in the determination of lot area coverage. The applicant shall clearly indicate on a plot plan the areas intended for residential use and the areas intended for commercial use. Sewage and water system approvals from both the Ohio EPA and County Board of Health shall be required.
- E. Food and lodging serving the occupants of the building, but not open to the general public.

Section 18.04 Development Standards

18.04.01 Minimum Lot Area

No minimum lot area is required; however, lot area shall be adequate to provide for the required parking and yard areas.

18.04.02 Minimum Lot Width

All lots shall have at least 100 feet of continuous frontage on a publicly dedicated and improved federal, state, township or county highway. Such lot width shall be adequate to accommodate all required parking areas, yards and vehicle circulation lanes.

18.04.03 Minimum Front Yard Depth

130 feet from the centerline of any state or federal highway; 90 feet from the centerline of any county or township road.

18.04.04 Minimum Side Yard

When abutting a non-residential zoning district, twenty (20) feet for structures, ten (10) feet for paved areas. When abutting a residential zoning district, fifty (50) feet for structures, thirty-five (35) feet for paved areas.

18.04.05 Minimum Rear Yard

When abutting a non-residential zoning district, thirty (30) feet for structures, ten (10) feet for paved areas. When abutting a residential

zoning district, fifty (50) feet for structures, thirty-five (35) feet for paved areas.

18.04.06 Parking and Loading

Parking and loading spaces shall be provided as required in this Resolution. In addition, parking spaces shall be designed to allow a minimum of five (5) feet between any structure and any parked vehicle.

18.04.07 Trash and Garbage Control

All trash and garbage shall be stored in container systems which are located and enclosed so as to effectively screen them from view.

18.04.08 Lighting

Lighting shall be arranged so as not to shine on adjacent properties.

18.04.09 Maximum Building Height

Forty (40) feet.

ARTICLE XIX

(NC) NEIGHBORHOOD COMMERCIAL DISTRICT

Section 19.01 Purpose

The NC District is intended to provide opportunity for development of small retail commercial and related uses. Neighborhood Commercial permitted uses are generally intended to serve neighborhood or local areas. Development standards of the District therefore limit the size and nature of uses to locally oriented, lower-intensity commercial functions. Because of these controls, the NC District may be used as an intermediate zone between higher-intensity commercial and/or industrial and residential uses. Neighborhood Commercial areas should generally be located at or near intersections on the Township arterial road system.

Section 19.02 Permitted Uses

- A. All permitted uses of the SO District, and Conditional Uses of the SO District in association with an SO permitted use, except for that use specified in Section 18.03 D.
- B. Grocery stores, drug stores, fruit and vegetable markets, other food markets, retail bakeries, florists, clothing shops, book shops, state liquor stores, antique furniture and novelty shops, gift shops, art galleries, jewelry stores, camera stores, hobby shops, fur sales and storage, and other similar retail stores, excepting sales of adults-only material.
 - 1. No retail store in the NC District shall exceed five thousand (5,000) square feet in total retail sales area. (For larger stores, refer to the Planned Business District or the General Commercial District).
- C. Restaurants and food preparation services for consumption on the premises. No take-out sales activities shall be permitted and no provision of live entertainment shall be permitted.
- D. Small item service and repair shops, including shoes, watches and jewelry, furniture, television and other electrical appliances, bicycles, and similar items. Repairs of automobiles, auto parts, boats, motorcycles, trucks, and other similar engine or machinery repairs shall not be permitted in the NC District.
- E. Barber and Beauty shops having no more than three work stations.

Section 19.03 Conditional Uses

- A. Lawn and garden stores and similar uses, provided all outside storage or sales areas are totally screened from view from any adjacent Residential District or residential use. The NC 5,000 square foot retail limit shall apply to all indoor sales areas, but shall not apply to outdoor sales or storage areas. If conducted in conjunction with the retail sales of such items, the service and repair of lawnmowers, snow blowers, chainsaws and similar small items, provided that all such repairs and service is conducted within a completely enclosed structure.
- B. Drive-in facility developed in association with a permitted use. In addition to the standards of Article IX, the following standards shall be met:
 - 1. The Board of Zoning Appeals may require the applicant submit a traffic analysis and detailed plot plan performed by a registered engineer demonstrating proposed drive-in facility will not create traffic congestion or unsafe points of traffic conflict. All parking, ingress, egress, and interior circulation shall be clearly marked with striping and/or curb barriers.
 - 2. The proposed drive-in facility and access drive shall conform to all building setback and other development standards and shall be screened by plantings or other appropriate methods when adjacent to residential areas.
 - 3. No food shall be served from the drive-in facility.
- C. Laundromats, dry cleaners and similar personal apparel services, provided that no such use emits odors perceptible outside of the building in which such use is established.
- D. Nursery schools and day care facilities.

Section 19.04 Development Standards

19.04.01 Minimum Lot Area

No minimum lot area is required; however, lot area shall be adequate to provide for the required parking and yard areas.

19.04.02 Minimum Lot Width

All lots shall have at least 100 feet of continuous frontage on a publicly dedicated and improved federal, state, township or county highway. Such lot width shall be adequate to accommodate all required parking areas, yards and vehicle circulation lanes.

- 19.04.03 **Minimum Front Yard Depth**
- 130 feet from the centerline of any state or federal highway; 90 feet from the centerline of any county or township road.
- 19.04.04 **Minimum Side Yard**
- When abutting a non-residential zoning district, twenty (20) feet for structures, ten (10) feet for paved areas. When abutting a residential zoning district, fifty (50) feet for structures, thirty-five (35) feet for paved areas.
- 19.04.05 **Minimum Rear Yard**
- When abutting a non-residential zoning district, thirty (30) feet for structures, ten (10) feet for paved areas. When abutting a residential zoning district, fifty (50) feet for structures, thirty-five (35) feet for paved areas.
- 19.04.06 **Parking and Loading**
- Parking and loading spaces shall be provided as required in this Resolution. In addition, parking spaces shall be designed to allow a minimum of five (5) feet between any structure and any parked vehicle.
- 19.04.07 **Trash and Garbage Control**
- All trash and garbage shall be stored in container systems which are located and enclosed so as to effectively screen them from view.
- 19.04.08 **Lighting**
- Lighting shall be arranged so as not to shine on adjacent properties.
- 19.04.09 **Maximum Building Height**
- Forty (40) feet.

ARTICLE XX

(GC) GENERAL COMMERCIAL DISTRICT

Section 20.01 Purpose

The GC District is intended to provide suitable areas for the location of moderate sized retail and commercial uses, which serve the needs of the Township and surrounding communities. Because of the size, scope and/or intensity of uses permitted, GC Districts should not be located adjacent to or in close proximity to residential areas. Direct access to arterial roads or abutment to industrial areas is prerequisite for rezoning to the GC category. Through the conditional use procedure, certain uses which have both commercial and industrial characteristics may be conditionally permitted, provided such uses can meet development standards which are designed to make them functionally and aesthetically compatible with the surrounding community.

Section 20.02 Permitted Uses

- A. All permitted uses and conditional uses of the Suburban Office (SO) and Neighborhood Commercial (NC) Districts, except for that use specified in Section 18.03 D.
- B. Retail stores (including those which exceed the maximum square footage limitations of the NC District) primarily engaged in selling merchandise for personal or household consumption and rendering services incidental to the sale of those goods, provided all storage and display of merchandise shall be within the principal structure, including:
 - 1. Food and food products consisting of: grocery stores, meat and fish markets, fruits stores and vegetable markets, and specialty stores such as bakery, candy or confectionery.
 - 2. Proprietary drug and hardware stores.
 - 3. Similar retail stores including florists, gift, antique or second-hand stores, books and newspapers, sporting goods, jewelry, optical goods, and other retail stores which may conform to the purpose of the GC District.
- C. Personal services involving the care of the person and his/her personal effects, including consumer services generally involving the care and maintenance of tangible personal consumption, including:
 - 1. Sit-down restaurants, bars and taverns.
 - 2. Barber and beauty shops.
 - 3. Funeral services.
 - 4. Radio, television or small appliance repair.
 - 5. On-premises duplication and reproduction services.
 - 6. Equipment rental or leasing, not to include the outside storage of equipment.

- D. Nursery schools and day care facilities.
- E. Commercial recreational facilities within an enclosed building, such as skating rinks, bowling alleys and physical fitness centers.
- F. Lumber and home improvement sales.
- G. Hotels and motels.
- H. Garden centers.

Section 20.03 Conditional Uses

- A. Institutions for human care, including congregate or group homes, hospitals, clinics, sanitariums and homes for the elderly, provided that any building or parking/service area is located not less than 200 feet from any adjacent residential property.
- B. Kennels or animal hospitals provided all buildings and outside runs are located not less than 200 feet from any adjacent residential property.
- C. Carry out food and beverage establishments with drive-through facilities, provided a plan for traffic circulation and parking, submitted by the applicant, and is approved by the Board of Zoning Appeals.
- D. Establishments selling gasoline, kerosene and/or diesel fuel, provided that all buildings and parking/service areas are located not less than 200 feet from any adjacent residential property and that a plan for traffic circulation and parking, submitted by the applicant, is approved by the Board of Zoning Appeals.
- E. Motor vehicle sales and service establishments, provided that all buildings and parking/service areas are located not less than 200 feet from any adjacent residential property. Any inoperable, unlicensed or unused vehicle shall not be stored outside the principal building for a period of time exceeding twenty-four (24) hours.
- F. Self-service storage facilities for the storage of personal property offered on a rental basis. In addition to any other criteria contained in this Resolution, these facilities shall comply with the following additional criteria:
 - 1. Self-service storage facilities are defined as a structure or structures on permanent foundation(s), comprised of self-contained, enclosed, individual storage spaces of varying sizes and which are leased or rented to tenants who are to have access to such space for the purpose of storing and removing personal property.

2. There shall be a minimum of four off-street parking spaces located adjacent to the leasing office and there shall be one additional parking space provided adjacent to the leasing office for each employee working on a single or combined work shift.
3. Parking for purpose of tenant's access to storage units shall be provided by parking/driving lanes adjacent to the self-storage buildings. These lanes shall be at least twenty-five (25) feet wide when storage spaces open onto one side of the lane only and at least thirty (30) feet wide when storage spaces open onto both sides of the lane.
4. An area devoted to self-service storage facilities shall be located on a lot or portion of a lot containing a minimum of one acre but not greater than three (3) acres in size.
5. No business activity other than the rental of storage units shall be conducted on the premises including the following prohibited uses:
 - a. Commercial, wholesale, or retail sales, or other miscellaneous garage sales;
 - b. The servicing, repair, or fabrication of motor vehicles, boats, trailers, lawn mowers, appliances, or other similar equipment;
 - c. The operation of power tools, spray painting equipment, table saws, lathes, compressors, welding equipment, kilns, or other similar equipment;
 - d. The establishment of a transfer and storage business;
 - e. Any use that is noxious or offensive because of odors, dust, noise, fumes or vibrations;
 - f. Any outside storage area shall not be permitted as a part of the required Conditional Use Development Plan;
 - g. The storage of explosives, radioactive materials and flammable or hazardous chemicals shall be prohibited; and
 - h. No individual storage unit size shall exceed 300 square feet.
6. No self-service storage facility shall exceed twenty (20) feet in height and shall be no greater than one (1) story.
7. All areas on the site not covered by pavement or structures must be brought to finished grade and planted with turf or other appropriate ground cover(s) and with deciduous and/or coniferous plant materials. The area located between a street and a self-service storage facility shall be fully landscaped including trees, shrubbery, lawn area, and/or decorative block wall or earth mound treatment.

G. Equipment rental or leasing, not to include the outside storage of equipment.

Section 20.04 Development Standards

20.04.01 Minimum Lot Area

No minimum lot area is required; however, lot area shall be adequate to provide for the required parking and yard areas.

20.04.02 Minimum Lot Width

All lots shall have at least 100 feet of continuous frontage on a publicly dedicated and improved federal, state, township or county highway. Such lot width shall be adequate to accommodate all required parking areas, yards and vehicle circulation lanes.

20.04.03 Minimum Front Yard Depth

One hundred thirty (130) feet from the centerline of any state or federal highway; 90 feet from the centerline of any county or township road.

20.04.04 Minimum Side Yard

When abutting a non-residential zoning district, twenty (20) feet for structures, ten (10) feet for paved areas. When abutting a residential zoning district, fifty (50) feet for structures, thirty-five (35) feet for paved areas.

20.04.05 Minimum Rear Yard

When abutting a non-residential zoning district, thirty (30) feet for structures, ten (10) feet for paved areas: When abutting a residential zoning district, fifty (50) feet for structures, thirty-five (35) feet for paved areas.

20.04.06 Parking and Loading

Parking and loading spaces shall be provided as required in this Resolution. In addition, parking spaces shall be designed to allow a minimum of five (5) feet between any structure and any parked vehicle.

20.04.07 Trash and Garbage Control

All trash and garbage shall be stored in container systems which are located and enclosed so as to effectively screen them from view.

20.04.08 Lighting

Lighting shall be arranged so as not to shine on adjacent properties.

20.04.09 Maximum Building Height

Forty (40) feet (except for self-service storage facilities).

ARTICLE XXI

Planned Unit Development Districts

Section 21.01 Purpose of Planned Unit Development Districts

This Article XXI is organized as authorized under Ohio Revised Code Section 519.021(A). Increased urbanization and population growth create increased demands for well-organized areas which take into account unique natural features, historic preservation, contemporary land use concepts, a balanced environment, comprehensive and orderly expansion of needed infrastructure and transportation systems and balanced, sustainable fiscal growth for the community. Planned Unit Development (PUD) Districts encourage and provide a means for effectuation of a more desirable physical development pattern than would be possible through the strict application of land uses, density and dimensional requirements, but also consider the way in which land uses are executed. Each planned development district shall promote the general public welfare, encourage the efficient use of land and resources, promote greater efficiency in providing public and utility services, and encourage innovation in planning and building all types of development.

Section 21.012 Applicability

The provisions of this Article of the Zoning Resolution may be applied only to lands of the Township that have been approved for a Zoning Map amendment to one of the following PUD Districts:

- A. Planned Conservation Residential District (PCRD) [Section 21.03]
- B. Planned Unit Residential Development District (PURD) [Section 21.04]
- C. Planned Business District (PB) [Section 21.05]
- D. Planned Industrial District (PI) [Section 21.06]

The action of the Township upon a rezoning application processed pursuant to this Article shall be considered a legislative act, subject to referendum.

Section 21.013 Procedure to Secure Approval for a Planned Unit Development District

In addition to the procedure set forth in Article VI of this Resolution, all applications for amendments to the zoning map to rezone property to a PUD District shall comply with the provisions set forth in this Article XXI. If a property is rezoned to a PUD District, the preliminary development plan and text approved by the Board of Township Trustees as a part of the rezoning shall be the zoning regulations applicable, and unique to that Planned Unit Development District. The regulations for all Planned Unit Development Districts are not required to be uniform but should, unless otherwise approved during the rezoning process, maintain the minimum standards as set forth in this Resolution.

Section 21.014 Planned Development District Pre-Application Meeting

The applicant is encouraged to engage in informal consultations with staff from the Zoning Commission and the Pickaway County Regional Planning Commission prior to formal submission of an application for an amendment of the Zoning Resolution. No statement or action by Township or County officials in the course of these informal consultations shall be construed to be a waiver of any legal obligation of the applicant or of any procedure or formal approval required by Township or County statutes or rules.

Section 21.015 Application and Preliminary Development Plan

Application for rezoning of property to a Planned Unit Development District shall be made by submission of the application for rezoning and at least fifteen (15) copies of a preliminary development plan and text to the Zoning Commission. The preliminary plan shall conform to the requirements for a Sketch Plan, referred to in, and prepared in accordance with, the Pickaway County Subdivision Regulations, and any preliminary development plan and text shall be prepared and endorsed by a qualified urban planner, landscape architect, or engineer and shall include the following information presented in a general, schematic fashion drawn to a scale of at least 1" = 100'. In addition to the material required for amendment as specified in Section 6.03 of this Resolution, the preliminary development plan and text shall include, in text and map form, the following information:

- A. Proposed location and size of the proposed planned district. This includes a survey map of the boundaries of the site and a legal description.
- B. Concept site plan of the proposed planned district.
- C. Proposed land uses, population densities, and building intensities. Any proposed use may be limited to specific areas delineated in the preliminary development plan and text.
- D. Proposed parks, playgrounds and other public or open spaces including woodland preservation and natural topography preservation areas with their suggested ownership.
- E. Locations of stream channels, watercourses, wooded areas and buffer areas shall be designated. Existing topography and drainage patterns shall also be shown.
- F. Relation to existing and future land use in surrounding area.
- G. Proposed provision of water, sanitary sewers, and surface drainage.
- H. Proposed traffic circulation pattern, indicating both public and private streets or highways, access points to public rights-of-ways and any off-site street improvements.

- I. An anticipated schedule for the development of units to be constructed in progression and a description of the design principles

for buildings and streetscapes; tabulation of the number of acres in the proposed phase for various uses, the number of housing units proposed by type; estimated residential population by type of housing; estimated nonresidential population; proposed retail sales area; building heights; open space; building intensity; parking areas; population density and public improvements proposed.

- J. Engineering feasibility studies and schematic plans showing, as necessary, water sewer, and other utility installations, waste disposal facilities, surface drainage, street improvements; and nature and extent of earth work required for site preparation and development.
- K. Site plan, showing approximate building locations(s), various functional use areas, circulation, and their relationship.
- L. Preliminary building plans, including floor plans and exterior elevations with details on building materials. Also, general architectural design criteria for proposed signs and exterior lighting with proposed control features.
- M. Deed restrictions, protective covenants, and other legal statements or devices to be used to control the use, development and maintenance of the land, the improvements thereon, including those areas which are to be commonly owned and maintained.
- N. Projected schedule of site development.
- O. Evidence that the applicant has sufficient control over the land to carry out the proposed development.
- P. Regulation text for development in the proposed Planned Unit Development District. That text must set forth the uses to be permitted in the proposed Planned Unit Development District.
- Q. Specific statements of divergence from the development standards established in this Article or in other Articles of this Resolution and the justification therefore. Unless a variation from those development standards is specifically requested and approved, the same shall be complied with.
- R. Architectural design criteria for all structures and criteria for proposed signs with proposed control procedures.
- S. A preliminary traffic impact analysis based upon new trip generation.
- T. Narrative discussion specifically referencing each point listed in Section 21.06.

After an application is filed, the Zoning Commission may request that the applicant provide such additional information concerning the proposal as necessary to clarify questions pertaining to the application.

Section 21.016 Rezoning to Planned Unit Development District Request and Preliminary Development Plan Review

The application for rezoning to a Planned Unit Development District and the preliminary development plan and text shall be considered and acted upon in accordance with the procedures set forth in this Resolution. The text shall be as detailed and complete as to clearly define the development proposed. The following

shall be considered in reviewing the rezoning application and preliminary development plan and text:

- A. Whether the proposed development is consistent with the intent, purpose criteria and standards of this Resolution.
- B. Whether the proposed development advances the health, safety and general welfare of the Township and immediate vicinity.
- C. Whether the proposed development is consistent with the policies and goals of Scioto Township and in conformity with applicable plans for the area.
- D. Whether the benefits, combination of various land uses, and interrelationship with land used in the surrounding area justify the proposed deviation from standard district regulations.
- E. Whether the uses proposed will be detrimental to present and potential surrounding area uses, or will have a beneficial effect which could not be achieved under standard district regulations.
- F. Whether the streets and thoroughfares proposed are suitable and adequate to carry anticipated traffic, and increased densities will not generate traffic in such amounts as to overload the street network outside the Proposed Planned Unit Development District.
- G. Whether the development will have a beneficial or an adverse effect upon Township and other governmental services.
- H. Whether the area surrounding said development can be planned and zoned in coordination and substantial compatibility with the proposed development.
- I. Whether the existing and proposed utility and governmental services are adequate for the population densities and nonresidential uses proposed.
- J. Whether the proposed development is in keeping with the existing land use character and physical development potential of the area.
- K. Whether the proposed development will be compatible in use and appearance with surrounding land uses.
- L. Whether the proposed development promotes greater efficiency in providing public and utility services and encouraging innovation in the planning and building of all types of development.
- M. Whether the benefits, improved arrangement and design of the proposed development justify rezoning the property to the PUD District.

Section 21.017 PUD Subsequent Use or Development of Property – Final Development Plan

In the PUD District, no use shall be established or changed and no structure shall be constructed or altered until a Final Development Plan for each such use and/or structure has been approved by the Township Trustees. Property which has been rezoned to a PUD District may be approved for development in phases. Each phase shall require approval of a Final Development Plan for that phase pursuant to the procedures set forth herein.

Application for Final Development Plan approval of each phase of the subsequent use or development of property rezoned to a PUD District shall be submitted to the Zoning Commission with at least fifteen (15) copies, shall contain the following documents and supporting information, prepared and endorsed by qualified professional(s), which shall include a licensed architect, registered land surveyor, registered civil engineer or registered landscape architect, and shall comply with regulations applicable to that PUD District. The Final Development Plan shall be drawn to a scale of at least 1" = 100'.

- A. A survey of the proposed phase, showing the dimensions and bearings of the property lines, the relationship of that phase to the Planned Unit Development District in which it is located, area in acres, topography, existing features of the development site, including agricultural drain tiles and their lay out, specimen trees, structures, streets, easements, utility lines, and land use;
- B. A detailed development plan showing, as appropriate, the following for that phase:
 - 1. Name and address of applicant.
 - 2. Names and addresses of owners and developers.
 - 3. Specific uses to be included within the proposed development, specified according to area or specific building location.
 - 4. Residential density and dwelling types.
 - 5. Nonresidential building intensity.
 - 6. Layout of proposed streets, including their names and rights of way, easements, sewers, water lines, culverts and other major improvements.
 - 7. Layout, numbering and dimensions of lots if more than one.
 - 8. Layout, location, dimensions and architectural features of proposed structures.
 - 9. Parcels of land intended to be dedicated or temporarily reserved for public use or reserved by deed covenant with the condition proposed for such covenant, and for the dedications.
 - 10. Building setback lines with dimensions.
 - 11. Tentative street grades and sewer size slope.
 - 12. Traffic circulation, parking areas, curb cuts and pedestrian walks.
 - 13. Engineering feasibility studies of any anticipated problems which may arise due to the proposed development as required by the Zoning Commission.
 - 14. Preliminary drawings for buildings to be constructed in the current phase, including floor plans, exterior elevations and sections.
 - 15. Color rendering of buildings(s), complete with a listing of all colors, including Pantone 1999-2000 Reference Numbers or if Pantone is not available, the manufacturer's reference/serial number with sample, and materials, with samples to be used.
 - 16. Building locations depicting the bulk, height and spatial relationships of building masses with adjacent development.
 - 17. Signage and exterior lighting details.
 - 18. Accommodations and access for emergency and firefighting apparatus.
 - 19. The general development character of the tract including the limitations or controls to be placed on all uses. Other development features, including signage, pathways, sidewalks, recreational facilities and all

- commonly owned structures shall be shown in detail which identifies the quantity and type and typical section of each. Open spaces and the intended uses therein and its acreage shall be provided and shown.
20. Deed restrictions, protective covenants, and other legal statements or devices to be used to control the use, development and maintenance of land, and the improvements thereon, including those areas which are commonly owned and maintained.
 21. Architectural design and exterior construction material criteria for all structures.
 22. The management plan or mechanism to provide for the perpetual maintenance of all landscaping, buffers and shared parking areas by the ultimate owner and/or user.
 23. Any additional information as may be required by the Zoning Commission.
- C. Landscaping and lighting plans for streetscapes, public areas, entrance features, and any other areas for which landscaping is required by the regulations applicable to that Planned Unit Development District adopted pursuant to the applicable sections of this Resolution. The landscape plan shall identify typical elevations and cross sections of landscape features, with the names of plants, shrubs or trees intended to be used.
- D. The various plans that make up the Final Development Plan shall bear the seal of a professional engineer, surveyor and an architect or landscape architect, each of whom shall be licensed to practice in the State of Ohio, and shall stamp their individual plans.

Section 21.017E FIRE APPARATUS (Effective date 10/19/2019)

SECTION E101.1 GENERAL

E101.0 Scope

Fire apparatus access roads shall be in accordance with this appendix and all other applicable requirements of the *International Fire Code*.

SECTION E102 REQUIRED ACCESS

E102.1 Access and loading

Facilities, building or portions of buildings hereafter constructed shall be accessible to fire department apparatus by way of an *approved* fire apparatus access road with an asphalt, concrete or other *approved* driving surface capable of supporting the imposed load of fire apparatus weighing up to 75,000 pounds (34 050 kg)

SECTION E103 MINIMUM SPECIFICATIONS

E103.1 Access road width with a hydrant

Where a fire hydrant is located on a fire apparatus access road, the minimum road width shall be twenty-six (26) feet (7925 mm), exclusive of shoulders (see Figure E103.1).

E103.2 Grade

Fire apparatus access roads shall not exceed 10 percent in grade.

Exception: Grades steeper than 10 percent as *approved* by the *fire code official*.

E103.3 Turning radius

The minimum turning radius shall be determined by the *fire code official*.

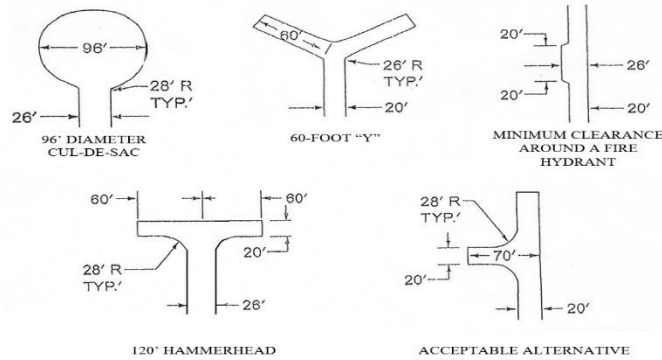

For SI: 1 Foot = 304.8 mm.

FIGURE E103.1
DEAD-END FIRE APPARATUS ACCESS ROAD TURNAROUND

2017 OHIO FIRE CODE

E103.4 Dead ends

Dead-end fire apparatus access roads in excess of One hundred fifty feet (150) ft (45 720 mm) shall be provided with width and turnaround provisions in accordance with Table E103.4.

TABLE E103.4 REQUIREMENTS FOR DEAD-END FIRE APPARATUS ACCESS ROADS

LENGTH (feet)	WIDTH (feet)	TURNAROUNDS REQUIRED
0-150	20	None required
151-500	20	120-foot Hammerhead, 60-foot "Y" or 96-foot diameter cul-de-sac in accordance with Figure D103.1
501-750	26	120-foot Hammerhead, 60-foot "Y" or 96-foot diameter cul-de-sac in accordance with Figure D103.1
Over 750		Special approval required

E103.5 Fire apparatus access road gates

Gates securing the fire apparatus access roads shall comply with all of the following criteria:

1. Where a single gate is provided, the gate width shall be not less than twenty feet 20 feet (6096 mm). Where a fire apparatus road consists of a divided roadway, the gate width shall be not less than twelve (12) feet (3658 mm).

2. Gates shall be of the swinging or sliding type.
3. Construction of gates shall be of materials that allow manual operation by one person.
4. Gate components shall be maintained in an operative condition at all times and replaced or repaired when defective.
5. Electric gates shall be equipped with a means of opening the gate by fire department personnel for emergency access. Emergency opening devices shall be *approved* by the *fire code official*.
6. Methods of locking shall be submitted for approval by the *fire code official*.
7. Electric gate operators, where provided, shall be *listed* in accordance with UL 325.
8. Gates intended for automatic operation shall be designed, constructed and installed to comply with the requirements of ASTM F2200.

E103.6 Signs

Where required by the *fire code official*, fire apparatus access roads shall be marked with permanent NO PARKING—FIRE LANE signs complying with Figure E103.6. Signs shall have a minimum dimension of twelve inches (12) inches (305 mm) wide by eighteen inches (18) inches (457 mm) high and have red letters on a white reflective background. Signs shall be posted on one or both sides of the fire apparatus road as required by Section E103.6.1 or E103.6.2.

FIGURE E103.6 FIRE LANE SIGNS

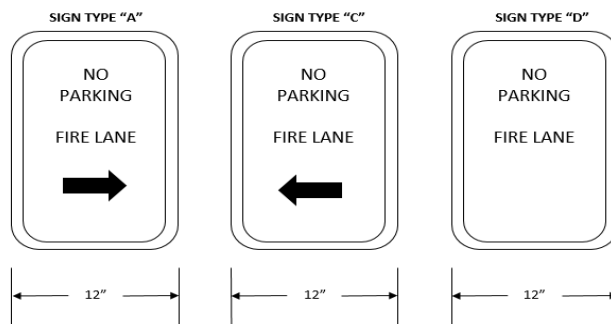

FIGURE D103.6
FIRE LANE SIGNS

E103.6.1 Roads 20 to 26 feet in width

Fire lane signs as specified in Section E103.6 shall be posted on both sides of fire apparatus access roads that are twenty feet (20) feet to twenty-six (26) feet wide (7925 mm).+

E103.6.2 **Roads more than 26 feet in width**

Fire lane signs as specified in Section E103.6 shall be posted on one side of fire apparatus access roads more than twenty-six (26) feet wide (7925 mm) and less than thirty-two (32) feet wide (9754 mm).

SECTION E104 COMMERCIAL AND INDUSTRIAL DEVELOPMENTS

E104.1 **Buildings exceeding three stories or 30 feet in height**

Buildings or facilities exceeding thirty (30) feet (9144 mm) or three stories in height shall have not fewer than two means of fire apparatus access for each structure.

E104.2 **Buildings exceeding 62,000 square feet in area**

Buildings or facilities having a gross *building* area of more than sixty-two thousand (62,000) square feet (5760 m²) shall be provided with two separate and *approved* fire apparatus access roads.

Exception: Projects having a gross *building area* of up to one hundred twenty-four thousand (124,000) square feet (11520 m²) that have a single *approved* fire apparatus access road where all buildings are equipped throughout with *approved automatic sprinkler systems*.

E104.3 **Remoteness**

Where two fire apparatus access roads are required, they shall be placed a distance apart equal to not less than one half of the length of the maximum overall diagonal dimension of the lot or area to be served, measured in a straight line between accesses.

SECTION E105 AERIAL FIRE APPARATUS ACCESS ROADS

E105.1 **Where Required**

Where the vertical distance between the grade plane and the highest roof surface exceeds thirty (30) feet (9144 mm), *approved* aerial fire apparatus access roads shall be provided. For purposes of this section, the highest roof surface shall be determined by measurement to the eave of a pitched roof, the intersection of the roof to the exterior wall, or the top of parapet walls, whichever is greater.

E105.2 **Width**

Aerial fire apparatus access roads shall have a minimum unobstructed width of twenty-six (26) feet (7925mm), exclusive of shoulders, in the immediate vicinity of the building or portion thereof.

E105.3 **Proximity to building**

One or more of the required access routes meeting this condition shall be located not less than fifteen (15) feet (4572 mm) and not greater than thirty (30) feet (9144 mm) from the building and shall be positioned parallel to one entire side of the building. The

side of the building on which the aerial fire apparatus access road is positioned shall be approved by the *fire code official*.

E105.4 Obstructions

Overhead utility and power lines shall not be located over the aerial fire apparatus access road or between the aerial fire apparatus road and the building. Other obstructions shall be permitted to be placed with the approval of the *fire code official*.

SECTION E106 MULTIPLE-FAMILY RESIDENTIAL DEVELOPMENTS

E106.1 Projects having more than 100 dwelling units

Multiple-family residential projects having more than 100 *dwelling units* shall be equipped throughout with two separate and *approved* fire apparatus access roads.

Exception: Projects having up to 200 *dwelling units* shall have not fewer than one *approved* fire apparatus access road where all buildings, including non-residential occupancies, are equipped throughout with *approved* automatic sprinkler systems installed in accordance with Section 903.1.1.1 or 903.3.1.2.

E106.2 Projects having more than 200 dwelling units

Multiple-family residential projects having more than 200 *dwelling units* shall be provided with two separate and approved fire apparatus access roads regardless of whether they are equipped with an *approved automatic sprinkler system*.

E106.3 Remoteness

Where two fire apparatus access roads are required, they shall be placed a distance apart equal to not less than one-half of the length of the maximum overall diagonal dimensions of the property or area to be served, measured in a straight line between accesses.

SECTION E107

ONE-OR-TWO FAMILY RESIDENTIAL DEVELOPMENT

E107.1 One-or-two family dwelling residential developments

Developments of one-or-two family *dwelling units* where the number of dwelling units exceeds 30 shall be provided with two separate and *approved* fire apparatus access roads.

Exceptions:

1. Where there are more than 30 *dwelling units* on a single public or private fire apparatus access road and all *dwelling units* are equipped throughout with an *approved automatic sprinkler system* in accordance with Section 903.1.1, 903.3.1.2 or 903.3.1.3 access from two directions shall not be required.

2. The number of dwellings units on a single fire apparatus access road shall not be increased unless fire apparatus access roads will connect with future development, as determined by the fire code official.

E107.2 Remoteness

Where two fire apparatus access roads are required, they shall be placed a distance apart equal to not less than one-half of the length of the maximum overall diagonal dimension of the property or area to be served, measured in a straight line between accesses.

SECTION E108 REFERENCED STANDARDS

ASTM	F2200—14	Standard Specifications for Automated Vehicular Gate Construction E103.5
UL	325—02	Door, Drapery, Gate, Louver, and Window Operations and Systems, with Revisions through May 2015 E103.5

Section 21.018 PUD Final Development Plan Application Review

Each application for approval of subsequent use or development in a PUD District shall be reviewed to determine whether the facts submitted with the application and presented at the hearings established that:

- A. The proposed phase complies with the approved preliminary development plan and text and the regulations applicable to the Planned Unit Development District in which it is located, as adopted pursuant to this Resolution.
- B. The proposed phase can be completed within three (3) years of the date of approval.

Section 21.019 Planned Unit District - Action on Final Development Plan Application

The application for the approval of a Final Development plan shall be submitted to the Zoning Commission for hearing and recommendation. The Zoning Commission shall establish a date for the hearing within a reasonable period of time following the filing of the application and shall give the applicant written notice at least ten (10) days before the date of the hearing. The Zoning Commission shall make a recommendation for the approval, modification or denial of the application within a reasonable period of time after it is submitted. The recommendation shall be forwarded to the Board of Trustees. The Board of Trustees shall hold a hearing on the application within a reasonable period of time after its receipt of the recommendation and shall give the applicant written notice at least ten (10) days before the date of the hearing. The Board of Trustees shall render a decision on the application within a reasonable period of time after the recommendation and application have been submitted to the Board of Trustees for its action. The decision of the Board of Trustees upon the application shall be effective immediately upon the action by the Board of Township Trustees. Such action shall not be subject to

referendum, but is subject to appeal pursuant to Chapter 2506 of the Ohio Revised Code.

Section 21.0110 Planned Unit Development District – Application Approval Period

The approval of an application for subsequent use or development of each phase of a Planned Unit Development District shall be for a period of three (3) years to allow the preparation and recording of the required subdivision plat(s) and the development of the project.

If no development has commenced to effectuate the Final Development Plan within three (3) years after approval of the application is granted, that approval shall be voided, and no further development of the land covered by that application shall be permitted unless another application for that land is approved under the procedures set forth herein.

Upon application by the owner(s), the Board of Trustees may extend the three (3) year time limit provided above. An application for extension shall be filed prior to the expiration of the established approval period. Such extension may be given upon a showing of the purpose and necessity for same and upon evidence that the owner(s) has made reasonable efforts toward the accomplishment of the originally approved Final Development Plan, and that such extension is not in conflict with the general health, safety and welfare of the public or the development standards of the applicable PUD District.

Section 21.0111 PUD District - Modification of Final Development Plan

- A. A request for minor changes to the Final Development Plan may be approved by the Township. Requests for minor changes shall initially be made to the Township Zoning Commission, who shall make a recommendation and forward it to the Board of Trustees. In approving such requests, the Township may impose such conditions, safeguards and restrictions in order to carry out the purpose and intent of this district.
- B. In the case of a request for a modification or amendment to the Final Development Plan that represents a substantial departure from the intent of the original proposal, said modification or amendment shall be subject to the same procedure and conditions of approval as the original application. The following shall be considered substantial departures from the original application:
 - 1. A change in the use or character of the development.
 - 2. An increase in the density or overall number of dwelling units.
 - 3. A reduction in approved open space.

4. A reduction of the acreage in the Planned Unit Development District.
5. An increase in overall ground coverage of structures.
6. An increase in the problems of traffic circulation or public utilities.
7. A reduction of off-street parking and loading space.
8. A reduction in required pavement widths.
9. Any other departure from the approved Final Development Plan which is deemed substantial by the Board of Trustees.

In approving such requests, the Township may impose such conditions, safeguards and restrictions in order to carry out the purpose and intent of this district.

Section 21.0112 Fees

A fee as established by the Board of Trustees shall accompany an application requesting approval of a zoning map amendment to a PUD District or a Final Development Plan. In addition, the applicant shall also be responsible for all reasonable and necessary expenses incurred by Scioto Township in using professional consulting services to review the request for a zoning map amendment or Final Development Plan. These expenses may include, without limitation, costs for professional consultants such as attorneys, architects, landscape architects, planners and engineers utilized by the Township in connection with reviewing the request for a zoning map amendment to a PUD District or a Final Development Plan and related application materials. As soon as reasonably practicable following the submission of an application for approval of a zoning map amendment or Final Development Plan, the Zoning Commission shall decide if it needs a professional consultant(s) to assist it in reviewing the application. If the Zoning Commission decides it needs professional consulting services, it shall designate the person(s) to be consulted and make an initial estimate of the expenses anticipated to be incurred in reviewing the application materials. The Zoning Commission shall provide the applicant with notice of its initial estimate of such expenses. This initial estimate will be reviewed, and may be revised, from time to time during the review process, and, if such review results in an increase in the estimated professional consulting fees and charges which will be incurred in the Township's review of the application materials, the Zoning Commission shall send the applicant written notice of the revised estimate of fees and charges. Within fourteen (14) days of the date of the notice of the initial estimate of fees and charges (and, if applicable, within fourteen (14) days of the date of the notice of any revised estimate), the applicant shall deposit in the office of the Township Fiscal Officer or the Fiscal Officer's designee, an amount equal to the estimated cost of the Township's expenses. In making the estimate of the professional consulting fees and charges anticipated to be incurred, the Zoning Commission shall consider the reasonable commercial rates of qualified professionals.

Section 21.0113 Phases

A project may be approved for development in phases. Each phase shall require approval of a Final Development Plan for that phase pursuant to the procedures set forth herein. An application for Final Development Plan approval for each phase of a project shall be annotated as to the as built conditions and shall be supplemented with an updated construction schedule. The phasing schedule shall be fully described in the preliminary development plan in a manner sufficient to give Township officials guidelines for the timing of future phases.

Section 21.02 Ownership of Open Space

Different ownership and management options apply to the permanently protected common open space created through the development process. The common open space shall remain in perpetuity and may be owned as identified in Section 21.021. A public land dedication, not exceeding ten percent (10%) of the total parcel size, may be required by the Township to facilitate trail or pathway connections. A narrative describing ownership, use and maintenance responsibilities shall be submitted for all common and public improvements, utilities, and open spaces. Common open space shall be prohibited from further subdivision or development. This prohibition may be done by placement in a reserve and notation on the final plat, or by other declaration or agreement in the chain of title to such property, with all being in a form acceptable to the Township.

Section 21.021 Planned Development District – Ownership Standards for Open Space

Common open space within the development shall be owned, administered, and maintained by any of the following methods, either individually or in combination, and subject to approval by the Township.

A. Offer of dedication

The Township shall have the first offer of undivided common open space in the event said land is to be conveyed to a public agency. Conveyance shall take the form of a fee simple ownership. The Township may, but is not required to, accept undivided common open space provided: 1) such land is accessible to all residents of the Township; 2) there is no cost of acquisition other than incidental costs related to transfer of ownership; 3) the Township agrees to maintain such lands. Where the Township accepts dedication of common space containing improvements, Township may require posting of financial security to ensure structural integrity of improvements for a term not to exceed eighteen (18) months.

B. Homeowners Association

The undivided common open space and associated facilities may be held in common ownership by a Homeowners Association. The Association shall be formed and operated under the following minimum standards:

1. The developer shall provide a description of the association, including its bylaws and methods for maintaining the common open space.
2. The Association shall be organized by the developer and shall be operated by the developer, before the sale of any lots or units within the development.
3. Membership in the Association shall be mandatory for all purchasers of property therein and their successors.
4. The Association shall be force funded.
5. The method for turning over the Association to the owners shall be identified.
6. The Association shall be responsible for maintenance of insurance and taxes on the undivided common open space. The Association shall establish rules to ensure proper maintenance of property, including monetary liens on the real property of its members who fail to pay their association dues in a timely manner.
7. The members of the Association shall share equitably the costs of maintaining and developing, where appropriate, such undivided common open space. Shares shall be defined within the Association bylaws.
8. The Association shall provide for adequate staff to administer common facilities and property and continually maintain the undivided common open space.
9. The Association may lease common open lands to any other qualified person, or corporation, for operation and maintenance of common open space lands, but such lease agreement shall provide: (i) That the residents of the development shall at all times have access to the common open space lands contained therein (except croplands during the growing season); (ii) That the undivided common open space shall be maintained for the purposes set forth in the approved Final Development Plan; (iii) That the operation of common open space may be for the benefit of the residents only, or may be open to all residents of the Township, at the election of the developer and/or homeowners association. In cases where public trails or paths are provided as linkage between developments or as a continuous link of common open space within the Township, all residents of the Township shall have access to such identified paths/walkways; (iv) The lease shall be subject to the approval of the association board and any transfer or assignment of the lease shall be further subject to the approval of the board. Lease agreements shall be recorded with the Office of the Pickaway County Recorder and notification shall be provided to the Township Trustees within 30 days of action by the board.

C. Condominium Association

The undivided common open space and associated facilities may be controlled through the use of condominium agreements, approved by the Township. Such agreements shall be in conformance with all applicable laws and regulations. All undivided common open space land shall be held as a common element.

D. Dedication of Easements

The Township may, but shall not be required to accept easements for public use of any portion or portions of undivided common open space land, title of which is to remain in ownership by condominium or homeowners associations, provided:

1. Such land is accessible to Township residents.
2. There is no cost of acquisition other than incidental transfer of ownership costs.
3. A satisfactory maintenance agreement is reached between the developer, association and the Township.

E. Transfer of Easements to a Private Conservation Organization

With the permission of the Township, an owner may transfer easements to a private, nonprofit organization, among whose purposes it is to conserve open space and/or natural resources; provided that:

1. The organization is acceptable to the Township, and is a bona fide conservation organization with perpetual existence.
2. The conveyance contains whatever provisions are agreed to between the Township Trustees, the owner and the organization.

F. Third party ownership

With the approval of the Township, open space may be owned by a third party if protected by either: 1) an open space easement which permanently and irrevocably transfers the development rights from the open space land to a property owners' or condominium association, the Township or a conservation organization; or 2) modifiable deed restrictions that permanently restrict the use of the open space to those uses identified in the approved Final Development Plan. Open space land to be transferred to a third party other than a property owners' association, condominium association or the Township shall also be located in a reserve with an open space notation on a recorded final plat.

Section 21.022 Planned Unit Development District – Maintenance of Open Space

A. Ownership

The ultimate owner of the open space shall be responsible for raising all monies required for operations, maintenance, or physical improvements to the open space through annual dues, special assessments, etc. The owner shall be authorized under the association bylaws to place liens on the property of residents who fall delinquent in payment of dues or assessments.

B. Failure to Maintain

In the event that the organization established to own and maintain common open space shall at any time after establishment of the PUD Development fail to maintain the common open space in reasonable order and condition in accordance with the Final Development Plan, such failure shall constitute a violation of this Zoning Resolution.

Section 21.03 Overview of Planned Conservation Residential District (PCRD)

PCRDs permanently preserve and integrate open space within residential developments; offer landowners alternatives to standard tract development of their land; establish a less sprawling, more efficient use of land, streets and utilities; preserve natural topography in wooded areas; create usable and accessible open space, recreational areas, and green corridors for wildlife, walking trails and/or bike paths; and encourage creativity in design through a controlled process of review and approval of the development plan and related documents. The minimum tract size for a PCRD shall be forty (40) acres, exclusive of existing right-of-ways.

Section 21.031 Planned Conservation Residential District Permitted Uses

- A. Single family detached residential dwelling units.
- B. Nonresidential uses of a religious, cultural, educational or recreational nature or character to the extent that they are designed and intended to serve the residents of the PCRD. Said facilities may be designed to serve adjoining neighborhoods or residents if they are located in such proximity to the major thoroughfares as to permit access without burdening residential streets.

- C. Public or Private golf courses, country clubs, fishing lakes or similar recreational uses with all buildings and club houses incident thereto including restaurant to serve members and/or users of the facility.
- D. Active recreation areas - Upon approval of the Final Development Plan by the Township, the following types of activities are permitted within open space, including but not limited to: bocce, baseball, basketball, softball, football, volleyball, badminton, golf, soccer, swimming, tennis, ice or roller skating, rollerblading, skateboarding, Frisbee, bird watching, horseshoes, canoeing, rowing, jogging, walking, gardening, and bicycling. If open space is intended to be used as a commercial recreational venture, it shall be so stated in the Final Development Plan and approved by the Township. All open space lands shall be permanently owned as provided in Section 21.021.
- E. Accessory service buildings and structures incidental and pertinent to the permitted uses listed above. Accessory service buildings must be necessary to the pursuit of a permitted recreational use on the premises.
- F. Natural (open space) areas – These areas may include passive recreational uses such as fishing, swimming, hiking, canoeing, and other recreation that does not alter any of the natural features of the area. Agriculture may be used as natural open space, provided it does not permit hog operations, poultry, fur bearing farms, or feed lots.
- G. Type B Family day care as provided in Ohio Revised Code Section 5101.04.
- H. Accessory Uses as follows:
 1. Temporary structures such as mobile office and temporary buildings of a nonresidential character may be used incidental to construction work on the premises or on adjacent public projects or during a period while the permanent dwelling is being constructed. The user of said structure shall obtain a permit for such temporary use, which permit shall be valid for six (6) months and may be renewed for additional six (6) month periods. Renewal of permit shall be at the discretion of the Zoning Inspector on finding of reasonable progress toward completion of the permanent structure or project. The Zoning Inspector may require provisions for sanitary waste disposal, solid waste disposal and water supply, as he/she deems necessary. The fees for such permit and renewals thereof shall be established by the Board of Township Trustees. Said temporary structure shall be removed no later than ten (10) days after expiration of said permit.
 2. Conducting of casual sale of goods as in garage sales or yard sales provided that such sales shall not be conducted on more than ten (10) days in any calendar year. The sale and parking area shall be out of the road right-of-way so as not to interfere with traffic on adjacent thoroughfares.
 3. Limited Home Occupation as provided in Section 29.02.

4. Model Homes, defined as residential-type structures used as sales offices by builders/developers and to display the builder's/developer's product. The same may be furnished within, since its purpose is to display to prospective buyers the builder/developer features (such as exterior siding treatment, roofing materials, interior trim, moldings, floor coverings, etc.), in the environment of a completed home. Model homes may be staffed by the builder/developer sales force. Model homes shall be subject to the following restrictions:
 - a. Lighting. All exterior lighting, except for security lighting, must be down-lighting, so that no light shall be cast onto adjoining residential properties. All off-street parking areas must be illuminated. All exterior lighting, except for security lighting, shall be extinguished at the closing time of the model home.
 - b. Parking. All model homes shall provide off-street paved parking for the public. The number of required parking spaces shall be at least six (6) per model home. The driveway of the model home may be utilized for not more than two (2) parking spaces.
 - c. Screening and Trash Receptacles. Landscape drawing shall be required and show adequate landscaping and screening from adjoining residential lots, together with the clear marking of the boundaries of the model home lot. Trash receptacles shall be provided around the model home.
 - d. Termination of Use. The use of model homes within a residential subdivision shall terminate when building permits have been issued for ninety-five percent (95%) of the lots within such subdivision.

Section 21.032 Designation of Uses

The applicant shall list in the preliminary development plan and text all permitted and accessory uses of the PCRD as applied to the specific tax parcels that are subject to the proposed rezoning. Uses not listed and approved as part of the preliminary development plan shall be prohibited. A Zoning Certificate will not be issued for uses not so listed.

Section 21.033 PCRD – Designing a Conservation Development

A Conservation Development is an open space development designed in accordance with the following suggested process and guidelines.

Section 21.034 PCRD – Designing a Conservation Development – Suggested Design Process

- A. Delineate primary conservation areas and preserve as natural open space.
- B. Delineate secondary conservation areas; preserve selected areas as common (improved) or natural open space.
- C. Draw house footprints outside the conservation areas.

- D. Draw the number of houses based upon the permitted density calculations, with lot lines.

Section 21.035 PCRD – Designing a Conservation Development – Suggested Design Guidelines

- A. In order to reduce visual impact, dwellings should typically be located along the edges rather than in the center of open fields if they will be seen from existing public roads. Avoid new construction on prominent hilltops or ridges.
- B. Front dwellings on internal roads, not on external roads.
- C. 75% or more of the total number of house lots should have a direct view of common open space.
- D. Retain or replant native vegetation adjacent to wetlands and surface waters.
- E. Preserve existing hedge and tree lines to the extent practicable.
- F. Preserve scenic views and vistas.
- G. Protect wildlife habitat areas of species listed as endangered, threatened, or of special concern by the Ohio Department of Natural Resources.
- H. Preserve historic or archaeological sites (i.e. earthworks, burial grounds).
- I. Landscape or retain vegetation in common areas with native trees and shrubs.
- J. Place shade trees along internal roads at fifty-foot intervals on at least one side of the road, not to interfere with drainage areas, road maintenance and traffic circulation.
- K. Provide active recreational areas in suitable locations.
- L. Include a viable pedestrian circulation system, meaning a minimum of a five foot wide asphalt bike and walking path throughout the development.
- M. Protect natural drainage swales and creeks. No filling and construction inside the 100 year floodplain or within one hundred feet (100') of the centerline of perennial streams and seventy-five feet (75') of the centerline of intermittent streams and agricultural drainage ditches.
- N. Provide permanent open space.

Section 21.036 Additional Procedures to Rezone to a Planned Conservation Residential District

Prior to filing an application to rezone property to the Planned Conservation Residential District, an applicant shall comply with the following sequential steps:

- A. *Existing features map*
Prepare an Existing Features (Site Analysis) Map.

- B. *Submit existing features (Site Analysis) map without fee*
Prior to formal application, the applicant shall submit the existing features (site analysis) map for a tract(s) of land to be considered as a conservation subdivision with the Scioto Township Zoning Commission, and schedule an agreeable time to jointly visit the site for an on-site walkabout.

- C. *On-site walkabout*
The applicant, the Zoning Inspector, one member of the Zoning Commission and one member of the Board of Township Trustees may visit and view the site, at which time the primary and secondary conservation areas shall be identified. Members of the public in attendance at the walkabout wishing to walk the site shall execute a release of liability in favor of the Township, the applicant, and the property owner.

- D. *Conceptual Development Plan*
At the completion of the on-site walkabout a conceptual development plan should be quickly sketched on the existing features (site analysis) map by the applicant or his consultant for impromptu comments from those in attendance. No binding decisions or votes are made at the on-site walkabout. Following preparation of the conceptual development plan, the applicant may proceed to prepare and submit a formal rezoning application and preliminary development plan.

Section 21.037 PCRD Development Plan Standards – Tract Size

The gross area of a tract of land proposed to be developed in the PCRD shall be a minimum of forty (40) acres, exclusive of existing right-of-ways.

Section 21.038 PCRD Development Plan Standards – Open Space

- A. At least fifty percent (50%) of the gross tract acreage shall be designated as permanent open space, not to be further developed, unless an exception is granted by the Township.
- B. Open space locations and uses shall be identified on the preliminary development plan and shall be subject to the approval of the Township.
- C. Open space shall be owned, administered and maintained as identified on the preliminary development plan.
- D. With prior consent through Resolution of the Board of Trustees of Scioto Township, land may be transferred to the Township for

public purposes if approved as a part of the final development plan. Uses of land transferred to the Township for public purposes must be approved as a part of the Final Development Plan and may include, but are not limited to, trails and active recreation areas. The decision whether to accept an applicant's offer to dedicate open space for public use shall be at the discretion of the Township Trustees. Land dedicated to public purposes may count toward the open space requirement if approved on the preliminary development plan.

- E. At least fifteen percent (15%) of the minimum required open space shall be suitable for active recreation purposes in order to preserve a reasonable proportion of natural open space on the site, but no more than fifty percent (50%) of the total open space preserved shall be utilized for active recreational purpose.
- F. The preliminary development plan shall specify the purposes which open space areas are proposed. Any recreational facilities proposed to be constructed within open space areas shall be clearly shown on preliminary development plan. In calculating open space, areas of fee simple lots conveyed to homeowners shall not be included.
- G. Storm water management detention/retention ponds, plus constructed wetlands acting as detention basins, plus sewage treatment areas may count in their combined aggregate for up to 50% of the required open space.
- H. Any area of natural open space that is proposed to be disturbed during construction or otherwise not preserved in its natural state shall be shown on the preliminary development plan and, if required, shall be restored with vegetation that is compatible with the natural characteristics of the site. The method and timing of any restoration shall be set forth in the Final Development Plan.

Section 21.039 PCRD Development Standards – Determining number of dwelling units permitted and density exception

The number of dwelling units is dependent on the provision of centralized sanitary sewer as defined as follows:

- A. For land not serviced by centralized sewer, multiply the number of gross acres times fifty hundredths (0.50) dwelling unit per gross acre to obtain the maximum number of permitted dwelling units. Provide 50% of the gross acreage in permanent open space.
- B. For land served by centralized sanitary sewer, multiply the gross acreage to be developed by one (1.0) dwelling unit per gross acre

to obtain maximum number of dwelling units permitted. Provide 50% of the gross acreage in open space.

Section 21.0310 PCR Development Standards – Sewage Disposal

For centralized sanitary sewer usage, a feasibility letter shall be provided by the appropriate service provider indicating that sewer service is available with the capacity needed. For sites not served by public centralized sewer, sewage disposal feasibility shall be demonstrated by letter from either the Pickaway County Health Department or the Ohio EPA.

Section 21.0311 PCR Development Standards – Perimeter Setback

No building shall be constructed within 50 feet of the external boundary of the conservation subdivision.

Section 21.0312 PCR Development Standards – Pavement Standards for Parking Lots

Parking lots and private driveways do not have to meet street cross sectional standards, but parking lot drive aisles that connect to the public streets shall be constructed to Public Street cross sectional and design life standards within 50 feet of the edge of the public paved road.

Section 21.0313 PCR Development Standards – Paths

A five foot wide asphalt-covered walking or bike path is required for conservation subdivisions of more than 15 dwelling units. Paths shall be separated from the paved street surface by at least five feet (5') of landscaped or grassed strip. The Township may require paved or unpaved walkways to connect residential areas and open spaces.

Section 21.0314 PCR Development Standards – Other Criteria

A. Street Trees

Deciduous, broad leaf street trees with a minimum caliper of three inches (3") at planting shall be planted (or retained) at least every fifty (50) lineal feet along at least one side of the street(s), not to interfere with drainage areas, road maintenance and traffic circulation.

B. Minimum Front Setbacks

Dwelling Units and garages shall be set back a minimum of forty (40) feet from the street right-of-way.

C. Minimum Lot Size

Fifteen thousand (15,000) square feet for single family detached dwellings on fee simple ownership lots, or as otherwise approved on the Final Development Plan.

D. Minimum Lot Width at the Building Line

There should be a variety of lot widths for the single family lots in the development. However, no single family lot width may be less than 60 feet and at least 20% of the single family lots shall have widths of at least 100' or more.

E. Minimum Side Yards

Twelve and one-half (12½) feet each side for single-family units and their garages, with no encroachments. For non residential structures, the minimum separation between buildings units shall be thirty (30) feet.

F. Driveway Setbacks

Two feet from side lot line. Side-load garages shall provide at least 24 feet of paved apron, exclusive of the 2 foot side lot line for single family detached dwellings on fee simple ownership lots.

G. Minimum Rear Yard

30 feet for single family detached dwellings on fee simple ownership lots and attached garages. Fifteen (15) feet for accessory buildings. For all other principal structures, the rear yard shall be not less than forty (40) feet.

H. Building Height Requirement

No principal building in this district shall exceed forty-five (45) feet in height.

I. Minimum Dwelling Unit Floor Area

Single-family detached dwellings shall contain at least 1,400 square feet of floor area for one (1) story dwelling structures and 1,600 square feet of floor area for dwelling structures with one and one-half (1½) or more stories.

J. Landscaping

All yards, front, side and rear, shall be landscaped. All improved common open space shall be landscaped per the approved Final Development Plan. A landscape plan for the common open space and streetscape within road right-of-way shall be prepared by a licensed landscape architect showing the caliper, height, numbers, name and placement of all material, and shall be submitted with and approved as a part of the Final Development Plan.

K. Signage

Signage shall conform to the provisions of this Resolution.

L. Trash and Garbage Control

All trash and garbage shall be stored in container systems which are located and enclosed so as to effectively screen them from view.

M. Parking

Off-street parking shall be paved and provided, at the time of construction of each main structure or building, with adequate provisions for ingress and egress according to the Final Development Plan. In preparing and approving the parking plan, the provisions of this Resolution shall be incorporated, or a divergence requested.

N. Exterior Lighting

All exterior street lighting shall be as specifically approved as part of the Final Development Plan. Exterior lighting shall be arranged so as not to shine on adjacent properties.

O. Construction Traffic

The approved construction entrances shall be specified on the Final Development Plan. The developer shall be responsible for damage to any Township right-of-way arising out of the developer's construction activities.

P. Supplemental Conditions and Safeguards

The Zoning Commission and/or Board of Trustees may impose additional conditions relating to the development with regard to the type and extent of the public improvements to be installed; landscaping; improvements and maintenance of open space areas; and other development characteristics.

Q. Divergences

Except for density and the total percentage required for open space, the Township, as a part of the preliminary development plan and text approval, may grant divergences from any standard or requirement in this Article or contained elsewhere in this Resolution that is noted "as approved per plan." An applicant requesting a divergence from any such standard or requirement shall specifically list each requested divergence on the development standards text submittals. The applicant requesting a divergence shall demonstrate that the divergence will result in an increased benefit, improved arrangement and better design than would otherwise occur if no divergence were granted.

R. Other Requirements

Unless specifically supplemented by the standards contained in Article XXI, or those standards approved by divergence in the preliminary development plan

and text, the development shall comply with all the Additional Zoning Requirements applicable to all zoning districts as set forth in this Resolution.

Section 21.04 Overview of Planned Unit Residential District (PURD)

The PURD District is established to provide areas in Scioto Township for planned residential developments containing a variety of housing densities and a mixture of single and multiple family uses. It is anticipated that the PURD area will be served by centralized water and sanitary sewer. The further purpose of the district is to achieve:

- A. A greater choice of living environments by allowing a variety of housing and building types and densities within a single development.
- B. A development pattern integrating open space which preserves and utilizes natural terrain and geologic features, scenic vistas, trees and other vegetation and prevents the disruption of natural drainage patterns.
- C. A more efficient use of land than is generally achieved through conventional development, resulting in substantial savings through shorter utilities and streets.
- D. A development pattern in harmony with land use, density, transportation, and community facilities objectives of the Township.

Section 21.041 Planned Unit Residential District Permitted Uses

- A. Single family detached dwellings and multiple family dwelling structures having no more than four (4) dwelling units per building, provided that multiple family dwelling structures shall comprise no more than 10% of the total number of dwelling units in the PURD.

- B. Open Space, to include:

- 1. “Recreational Open Space,” meaning open space area which is designed and to be improved for active recreation, including but not limited to: baseball and soccer fields; jogging, walking and bike paths; playgrounds; outdoor swimming pools; shelter houses and picnic grounds; basketball and volleyball courts; and skating parks.

Within such areas, accessory service buildings and structures incidental and pertinent to the intended recreational activity may be erected if approved with the Final Development Plan. Such Open Space shall not be included within an individual residential lot. Such open space shall be mowed and maintained by the owner or responsible party.

- 2. “Maintained Passive Open Space,” meaning open space area which is designed and to be improved for passive recreation or aesthetic effect,

including but not limited to: open fields and meadows, walking and bike paths, entrance and landscaping features or landscape buffers, all of which are to be mowed and maintained by the owner or responsible party.

Within such areas trees and vegetation may be planted and structures not incompatible with such purposes may be erected if approved in the Final Development Plan. Such Open Space shall not be included within an individual residential lot.

3. "Unmaintained Passive Open Space," meaning undeveloped open space area which functions to: preserve a site's natural amenities; provide a cover for wildlife; and preserve scenic views, jurisdictional wetlands, floodplains or ravines. Unmaintained Passive Open Space shall be restricted in perpetuity from development with buildings, structures or uses and shall be preserved in its natural state.

Within areas designated as such Open Space, the natural resources shall remain undisturbed and no topsoil, clay, sand, gravel, rock or minerals shall be excavated or removed therefrom and nothing shall be permitted to occur thereon which would contribute to the erosion of the land and no trees or vegetation shall be cut or removed therefrom except such dead, diseased or decayed trees or vegetation as may be required for conservation or scenic purposes or for reasons of public safety.

No private encroachment shall occur within such Open Space including but not limited to: the planting of flowers, shrubs, garden material, etc.; dumping of trash, refuse, yard waste or debris; or the installation of any type of recreational or other facility or convenience.

No dumping or burning of refuse, trash, debris or yard waste shall occur in such Open Space. No hunting or trapping shall occur in such Open Space. Neither roadway nor any facility of any public utility other than existing roadways and public facilities designated in the Final Development Plan shall be constructed or installed therein, and no existing roadway or public utility facility shall be extended or enlarged within such area. Designation of such area shall not be interpreted to interfere with or detract from the use of such Open Space by the owner and their successors in interest for all purposes not inconsistent with the provisions herein.

It is the intent of the designation of such Open Space to restrict and prohibit any activity or use which would, as a natural consequence, impede or make more difficult the accomplishment of the purpose for which such Unmaintained Passive Open Space is created. Such Open Space shall not be included within an individual residential lot.

- C. Non-residential uses of a religious, cultural, educational or recreational nature or character to the extent that they are designed and intended to serve the residents of the PURD development. Said facilities may be designed to serve adjoining neighborhoods or residents if they are located in such proximity to major thoroughfares as to permit access without burdening residential streets.

- D. Schools with adequate area as approved per plan for indoor and outdoor recreation, parking and additional setbacks as may be necessary to avoid disruption to adjacent residences.
- E. Type B family day care as provided in Ohio Revised Code Section 5101.04.
- F. Other residentially-oriented uses which, in the opinion of the Zoning Commission and the Board of Trustees, meet the purpose and intent of the PURD District and are adequately designed, located and otherwise provided for by the Development Plan and other required documents.
- G. Accessory Uses as follows:
 - 1. Temporary structures such as mobile office and temporary buildings of a nonresidential character may be used incidental to construction work on the premises or on adjacent public projects or during a period while the permanent dwelling is being constructed. The user of said structure shall obtain a permit for such temporary use, which permit shall be valid for six (6) months and may be renewed for additional six (6) month periods. Renewal of the permit shall be at the discretion of the Zoning Inspector on finding of reasonable progress toward completion of the permanent structure or project. The Zoning Inspector may require provisions for sanitary waste disposal, solid waste disposal and water supply, as he/she deems necessary. The fees for such permit and renewals thereof shall be established by the Board of Township Trustees. Said temporary structure shall be removed no later than ten (10) days after expiration of said permit.
 - 2. Conducting of casual sale of goods in what are commonly referred to as garage sales or yard sales provided that such sales shall not be conducted on more than ten (10) days in any calendar year. The sale and parking area shall be out of the road right-of-way so as not to interfere with traffic on adjacent thoroughfares.
 - 3. Limited Home Occupation as provided in Section 29.02.
 - 4. Model Homes, defined as residential-type structures used as sales offices by builders/developers and to display the builder's/developer's product. The same may be furnished within, since its purpose is to display to prospective buyers the builder/developer features (such as exterior siding treatment, roofing materials, interior trim, moldings, floor coverings, etc.), in the environment of a completed home. Model homes may be staffed by the builder/developer sales force. Model homes shall be subject to the following restrictions:
 - a. Lighting. All exterior lighting, except for security lighting, must be down-lighting, so that no light shall be cast onto adjoining residential properties. All off-street parking areas must be illuminated. All exterior lighting, except for security lighting, shall be extinguished at the closing time of the model home.
 - b. Parking. All model homes shall provide off-street paved parking for the public. The number of required parking spaces shall be at least six (6) per model home. The driveway of the model home may be utilized for not more than two (2) parking spaces.

- c. Screening and Trash Receptacles. Landscape drawing shall be required and show adequate landscaping and screening from adjoining residential lots, together with the clear marking of the boundaries of the model home lot. Trash receptacles shall be provided around the model home.
- d. Termination of Use. The use of model homes within a residential subdivision shall terminate when building permits have been issued for ninety-five percent (95%) of the lots within such subdivision.

Section 21.042 Designation of Uses

The applicant shall list in the preliminary development plan and text all permitted and accessory uses of the PURD as applied to the specific tax parcels that are subject to the proposed rezoning. Uses not listed and approved as part of the preliminary development plan shall be prohibited. A Zoning Certificate will not be issued for uses not so listed.

Section 21.043 PURD Development Standards

In addition to any other provisions of this Resolution and unless the standards recited herein have been specifically modified in the development standards approved as part of the preliminary development plan, the following standards for arrangement and development of lands and buildings are required in the PURD District:

A. Minimum PURD Tract Size

The gross area of a tract of land proposed to be developed in a single PURD District shall be a minimum of twenty-five (25) acres exclusive of existing right-of-ways. This requirement may be reduced if all property abutting the subject tract is platted and/or developed.

B. Open Space

At least fifteen percent (15%) of the total gross acreage must be devoted to open space. Open space shall be designated upon the development plan as “Maintained Passive Open Space,” “Recreational Open Space” and “Unmaintained Passive Open Space” upon the basis of the definitions, purposes, requirements and conditions set forth in Section 21.041 of this Article. Public or private golf courses, with all buildings and club houses incident thereto, may not be designated as “recreational open space.”

Open space shall be designed to provide active recreation, passive recreation, the preservation of natural site amenities or any combination thereof for the use and benefit of the residents of the PURD District. Any buildings, structures and improvements to the

open space must be appropriate to the uses which are authorized for the open space, having regard to its topography and unimproved condition. The open space shall be of a size, shape and location which are conducive to use by residents of the property within the PURD District. Public utility and similar easements, rights-of-way for streets and roads, and rights-of-way for water courses and other similar channels are not acceptable for common open space dedication unless such land or right-of-way is usable as a trail or similar purpose and has been approved as part of the Final Development Plan.

Storm water retention or detention facilities are acceptable for dedication as Open Space, provided such facilities do not exceed thirty percent (30%) of the total open space required. At least sixty percent (60%) of the total open space shall be devoted to Recreational Open Space, provided that such percentage may be reduced by the Township if the Recreational Open Space Area is to be improved with an enclosed recreational center. The location, shape, size and character of the open space shall be suitable for the planned development in relation to the location, number and types of buildings it is intended to serve. In any case, it shall be highly accessible to all residents or users of the planned development. The open space shall be for the use and enjoyment of the owners and occupants of the individual building sites of the development and shall be accessible to all such owners and occupants. Any uses and/or buildings authorized for the open space must be appropriate to the scale and character of the planned development in relation to its size, density, expected population, topography, and the type of dwellings.

C. Utilities

All electrical, telephone, cable television, and similar utility transmission and distribution lines shall be located underground.

D. Arrangement of Non-Residential Uses and Parking

Off-street parking shall be paved and provided in accordance with the requirements for the individual uses that comprise the development and the standards of Article XXX of this Resolution. Parking areas shall be designed so as to utilize common ingress and egress points, reduce traffic congestion and mitigate potential conflict points. Parking areas shall be designed so as to discourage single, large, unbroken paved lots, and shall encourage smaller defined parking areas within the total parking system. Defined parking areas should be delineated and accented by landscaped areas. Projects developed in the PURD District shall provide for

the integrated and harmonious design of buildings and for adequate and properly arranged facilities for internal traffic circulation, landscaping, and such other features and facilities as may be necessary to make the project attractive and efficient from the standpoint of the adjoining and surrounding areas.

E. Residential Density (Revised effective 6/3/2018)

The maximum net density of the entire PURD development shall not exceed two (2) dwelling units per acre. The calculation of such density shall be based on the number of proposed dwelling units divided by the area of the site designated for residential use, excluding the following:

1. Existing street rights-of-way.
2. Existing bodies of water.
3. Floodplains within the FEMA 100-year floodplain.
4. Utility rights-of-way for above ground and currently existing utility structures such as above-ground pipelines and existing overhead electric transmission (not local service) wires.
5. Proposed rights-of-way for streets and utilities (15% of gross acreage when estimating density).
6. Slopes greater than twenty percent (20%).
7. Required open space.

F. Private Roads

Private roads or streets as a common easement may be used to provide internal circulation to clustered lots and/or individual residential structures in a PURD in accordance with the following requirements:

1. The easement shall not be counted as required open space.
2. The road or street is approved by the Pickaway County Engineer as the most appropriate form of access to lots and/or structures.

G. Setback Requirements (Revised effective 6/3/2018)

The physical relationship of the development, the dwelling units and their minimum yard space shall be determined in accordance with the following:

1. Perimeter PURD Setback. 100 feet from property lines.
2. Front. Single-family detached dwellings shall have a setback from the right-of-way line of adjacent roads of fifty (50) feet. All other structures within the PURD District shall have a setback from the right-of-way equal to the right-of-way of roads within the development or the right-of-way of existing roads.
3. Side. A single-family detached dwelling shall have a side yard of not less than twenty (20) feet on each side of the structure. For all other

principal structures within the PURD District the side yard shall be not less than thirty-five (35) feet. Porches cannot encroach upon said setbacks; however, eaves, awnings and chimneys will be allowed. The requirements for side yards herein shall apply to the principal structures but shall not be interpreted as prohibiting designs of single-family structures normally referred to as common wall, cluster, patio or other variations on the same theme.

4. Rear. Single-family detached dwellings shall have a rear yard of not less than thirty-five (35) feet. For all other principal structures within the PURD District the rear yard shall be not less than forty-five (45) feet.
5. Driveway Setbacks. Three feet from side lot line. Side-load garages shall provide at least 20 feet of paved apron, exclusive of the three feet setback.

H. Lot Dimensions (Revised effective 6/3/2018)

Lot dimensions shall be as follows:

1. Minimum Lot Area. The minimum lot area for single-family detached dwelling shall be 20,000 square feet. For multiple family dwellings, the minimum lot area shall be 15,000 square feet per dwelling unit. For all other principal structures, while no minimum lot area is required, the lot area shall be adequate to provide for the required parking and yard areas.
2. Minimum Lot Width. The minimum lot width shall be One-hundred (100) feet or more at the front building line and such lot shall have access to and abut on an adjoining approved street or road for a continuous distance of at least eighty (80) feet.

I. Floodplains

No residential dwelling structures shall be constructed within the 100-year floodplain of any stream or river.

J. Architecture

The project architect shall give due regard to the footprints, building orientation, massing, roof shape, pitch and exterior materials to blend with other traditional or historic architecture in the community or with the site.

K. Sidewalks (Revised effective 6/3/2018)

A network of sidewalks or walking paths shall be provided. Where located parallel to the roads, sidewalks shall be separated from street pavement by at least six (6) feet. Walking paths may be located per plan. The Board of Trustees may require paved/unpaved walkways to connect residential areas and open spaces. The homeowner shall be responsible for the maintenance and repair of sidewalks on their property.

L. Streets (Revised effective 6/3/2018)

All streets shall be (36) feet in width. Street parking is limited to one side of the street. Fire hydrants and mailboxes shall be located on the “No Parking” side of the street.

M. Building Dimensions. (Floor space requirements)

1. Single-family detached dwellings shall contain at least 1,400 square feet of floor area for one (1) story dwelling structures and 1,600 square feet of floor area for dwelling structures with one and one-half (1½) or more stories.
2. Multiple family dwelling structures shall contain at least 900 square feet of floor area per dwelling unit.

N. Building Height Limits

No building in this district shall exceed thirty-five (35) feet in height. All other freestanding residential structures including, but not limited to, flagpoles shall not exceed forty-eight (48) feet in height. All attached residential structures including, but not limited to, chimneys and church spires, shall not top at a height that is eight (8) feet greater than either the height of the building or structure to which it is attached.

O. Landscaping

All yards, front, side and rear, shall be landscaped, and all organized open spaces or non-residential use areas shall be landscaped. A landscape plan showing the caliper, height, numbers, name and placement of all material, prepared by a licensed landscape architect, shall be submitted as a part of the Final Development Plan.

P. Signage

Signage shall conform to the provisions of this Resolution.

Q. Trash and Garbage Control

All trash and garbage shall be stored in container systems which are located and enclosed so as to effectively screen them from view.

R. Parking

Off-street parking shall be paved and provided, at the time of construction of each main structure or building, with adequate provisions for ingress and egress according to the preliminary development plan and text. In preparing and approving the parking plan, the provisions of this Resolution shall be incorporated, or a divergence requested.

S. Exterior Lighting

All exterior street lighting shall be specifically approved as part of the preliminary development plan and text. Exterior lighting shall be arranged to not shine on adjacent properties.

T. Construction Traffic

The approved construction entrances shall be specified on the preliminary development plan and text. The developer shall be responsible for damage to any Township right-of-way arising out of the developer's construction activities.

U. Storm Water Runoff

Structures and physical changes to the site shall be designed and constructed so as not to cause a significant increase in storm water runoff onto adjacent properties.

V. Supplemental Conditions and Safeguards

The Zoning Commission and/or Board of Trustees may impose additional conditions relating to the development with regard to the type and extent of the public improvements to be installed; landscaping; improvements and maintenance of open space areas; and other development characteristics.

W. Divergences

Except for density and the total percentage required for open space, the Township, as a part of the preliminary development plan and text approval, may grant divergences from any standard or requirement in this Article or contained elsewhere in this Resolution that is noted "as approved per plan." An applicant requesting a divergence from any such standard or requirement shall specifically list each requested divergence on the

development standards text submittals. The applicant requesting a divergence shall demonstrate that the divergence will result in an increased benefit, improved arrangement and better design than would otherwise occur if no divergence were granted.

X. Other Requirements

Unless specifically supplemented by the standards contained in Article XXI, or those standards approved by divergence in the preliminary development plan and text, the development shall comply with all the Additional Zoning Requirements applicable to all zoning districts as set forth in this Resolution.

Section 21.05 Planned Business District Purpose (PB)

The purpose of the Planned Business District is to encourage the design and development of non-residential uses in a manner which enhances the Township's image through the application of design and architectural principles, high-quality construction techniques, preservation of existing natural resources, and the provision of aesthetic amenities. The Planned Business District also gives the Township the ability to permit a range of non-residential uses in a manner that ensures that such uses are compatible with the surrounding environment, specifically residential uses.

Section 21.051 Planned Business District Permitted Uses

- A. All permitted and conditional uses of the SO, NC and GC Districts, and other similar commercial and office uses if specifically identified and approved as part of the preliminary development plan.
- B. Community facilities such as libraries, offices or educational facilities operated by a public agency or government.
- C. Commercial establishments normally associated with and intended to service the traveling public with motels, service stations, restaurants and other related activities.
- D. Hospitals, medical facilities, nursing homes and convalescence homes.
- E. Medical, dental or optical laboratories.
- F. Nursery schools, day care facilities and adult care facilities.

Section 21.052 Designation of Uses

The applicant shall list in the preliminary development plan and text all permitted and accessory uses of the PB District as applied to the specific tax parcels that are subject to the proposed rezoning. Uses not listed and approved as part of the

preliminary development plan and text shall be prohibited. A Certificate of Zoning Compliance will not be issued for uses not so listed.

**Section 21.053 Planned Business District
General Development Standards**

In addition to any other provisions of this Resolution and unless the standards recited herein have been specifically modified in the development standards approved as part of the preliminary development plan, the following standards for arrangement and development of lands and buildings are required in the Planned Business District:

A. Screening

A use allowed in this district shall entirely enclose its operation within a structure or behind screening. Open storage, service areas and loading docks shall be screened from view by shrubbery, walls, fences or landscaped mounds at least six (6) feet, but not more than twelve (12) feet, in height. These walls, mounds, fences or shrubbery shall be of a design so as to effectively screen such storage, production or service areas and loading facilities from view of adjoining streets or other zoning districts. All such shrubbery shall be properly trimmed and all screening shall be maintained in a neat and tidy manner.

B. Lot Width and Size

There is no minimum lot size or width. However, all lands shall have continuous frontage on and be accessible by means of a duly dedicated and improved public roadway constructed in accordance with the specifications prescribed by the County Engineer or the subdivision Regulations of the county. All parcels shall be adequate in size to provide the yard space, landscaping and off-street parking as herein required.

C. Front Yard Building Setbacks

130 feet from centerline of any state or federal highway; 90 feet from the centerline of any county or township road; sixty-five (65) feet from the centerline of all other roads.

D. Side Yards

For principal and accessory structures, including open storage, processing, servicing or loading areas, the side yard shall be equal to one-third (1/3) of the sum of the height and width of the structure, but

in no case shall side yards adjacent to Residential Districts be less than one hundred (100) feet.

E. Rear Yards

For principal and accessory structures, including open storage, processing, servicing or loading areas, the rear yard shall be equal to one-third (1/3) of the sum of the height and width of the structure, but in no case shall rear yards adjacent to Residential Districts be less than one hundred (100) feet.

F. Perimeter Area

No building or parking shall be constructed within 100 feet of the perimeter property line of the overall tract, when abutting or adjacent to a residential use or a residential zoning district.

G. Building Height

No building shall exceed forty-five (45) feet in height.

H. Landscaping

All yards, front, rear and side, shall be landscaped. A landscape plan shall be submitted with the Final Development Plan and shall be subject to approval in the same manner required of the Final Development Plan. All landscaping used for screening purposes shall be non-deciduous. In addition, all undeveloped areas shall be adequately and regularly maintained by regular mowing, trimming and weed removal.

I. Signs

Signage shall conform to the provisions of this Resolution.

J. Parking

Off-street parking shall be paved and provided, at the time of construction of the main structure or building, with adequate provisions for ingress and egress according to the Final Development Plan. In preparing and approving the parking plan, the parking provisions of this Resolution shall be incorporated, or a divergence requested.

K. Exterior Lighting

All exterior lighting shall be specifically approved as part of the Final Development Plan. Exterior lighting shall be arranged so not to shine on adjacent properties/public streets.

L. Freight Loading Area

When any use within this district requires the pickup or delivery of merchandise or supplies, an adequate loading area for such activity shall be provided on the lot occupied by the use. No such loading area shall be located on any public street or alley. Such loading areas, as provided, shall be adequate in size to accommodate tractor-trailer (semi) units with adequate room to permit entry to such loading area without interfering with traffic on adjacent streets or highways.

M. Open Space

A minimum of 10% of the gross acreage shall be utilized as open space. Open space shall be distributed throughout the development as part of a unified open space system, which shall serve to unify the development visually and functionally, and buffer surrounding land uses. Open spaces may be used for the natural disposal of storm water drainage. No features should be designed which are likely to cause erosion or flooding.

N. Supplemental conditions and safeguards

The Zoning Commission and/or Board of Trustees may impose additional conditions relating to the development with regard to the type and extent of the public improvements to be installed; landscaping; improvements and maintenance of open space areas; and other development characteristics.

O. Divergence

The Township, as a part of the preliminary development plan and text approval, may grant divergences from any standard or requirement in this Article or contained elsewhere in this Resolution that is noted “as approved per plan.” An applicant requesting a divergence from any such standard or requirement shall specifically list each requested divergence on the development standards text submittals.

P. Other Requirements

Unless specifically supplemented by the standards contained in Article XXI, or those standards approved by divergence in the preliminary development plan and text, the development shall comply with all the Additional Zoning Requirements applicable to all zoning districts as set forth in this Resolution.

Section 21.054 Planned Business Performance Standards

No land or structure in the PB District shall be used or occupied in such a manner so as to create any dangerous, injurious, noxious or otherwise objectionable impact on

any land which is located in any other zoning district. Such impacts shall include those related to noise, vibration, odor, dust, glare, or storm runoff. Statements in writing that such uses comply or will comply with such uses may be required by Zoning Commission from the applicant. In addition to any other provisions of this Resolution, no use shall be conducted within this district which fails to maintain the following standards:

A. Noise

The sound pressure level of any operation on a lot within the PB District shall not exceed the average intensity of traffic noise in the nearest residential districts, and no sound shall be objectionable due to intermittence, beat frequency or shrillness.

B. Vibration

No vibrations which are perceptible without the aid of instruments shall be permitted, as measured on the boundary of the property in the PB District.

C. Odor

No emission of odorous matter in any quantities so as to produce a public nuisance shall be permitted, as measured on the boundary of the property in the PB District.

D. Dust and Smoke

The emission of smoke, soot, fly ash, fumes, dust or other types of pollutants borne by the wind shall be controlled so that the rate of emission and quantity deposited do not create a public nuisance, as measured on the boundary of the property in the PB District.

E. Glare

Exterior lighting shall be used in a manner that produces no glare on public highways or adjacent land.

F. Storm Runoff

Structures and physical changes to the site shall be designed and constructed so as to not cause a significant increase in storm water runoff onto adjacent properties.

Section 21.06 Planned Industrial District Purpose (PI)

The purpose of the Planned Industrial District is to encourage the design and development of areas where industrial, office, and limited commercial uses are located. Uses in the Planned Industrial District should not conflict with surrounding land uses and the overall site should be designed in a manner that protects existing natural resources, encourages sound traffic patterns, and incorporates high-quality construction techniques and the provision of aesthetic amenities.

Section 21.061 Planned Industrial District Permitted Uses

- A. Light manufacturing, compounding, processing, assembling, packaging, or treatment of goods, materials, and products, consistent with the purpose and development standards of the PI District.
- B. Warehousing, distribution and related uses, including truck and transfer terminals.
- C. Administrative, professional and business offices associated with and incidental to another permitted use.
- D. Motor vehicle storage and salvage yards, provided those uses meet applicable State requirements related to fencing and other standards.
- E. Contractor equipment and storage yards, provided adequate fencing and screening devices are installed.
- F. Quarrying or mining operations, provided that all county, state and federal regulations are met and licenses obtained.
- G. Structures and sites that drill for oil or natural gas.
- H. Sanitary landfills and similar facilities for the processing and/or disposal of waste materials provided that all required licenses and permits are obtained.
- I. Commercial establishments normally associated with and designed to serve the industrial establishments or their employees and approved as part of the development plan such as financial institutions, restaurants, gasoline service stations, automobile repair establishments, recreation or other personal enrichment facilities, provided such establishments or facilities are primarily for employees of industrial establishments developed as part of approved development plan for the Planned Industrial District.
- J. Storage of recreational vehicles, boats, trailers, construction equipment and similar vehicles.
- K. Other uses of an industrial nature not otherwise provided for in this Resolution.

- L. Municipal Waste Storage Facilities providing that all townships, county, state and federal requirements and regulations are met and licenses are obtained. A cleanup bond shall be required.

Section 21.062 Designation of Uses

The applicant shall list in the preliminary development plan and text all permitted and accessory uses of the PI District as applied to the specific tax parcels that are subject to the proposed rezoning. Uses not listed and approved as part of the preliminary development plan and text shall be prohibited. A certificate of zoning compliance will not be issued for uses not so listed.

**Section 21.063 Planned Industrial District
General Development Standards**

In addition to any other provisions of this Resolution and unless the standards recited herein have been specifically modified in the development standards approved as part of the preliminary development plan, the following standards for arrangement and development of lands and buildings are required in the Planned Industrial District:

- A. Lot Area

No minimum lot size is required; however, all principal and subordinate uses and structures, including parking and paved areas, shall be located not less than 500 feet from any district where residences are a permitted use, and not less than 50 feet from any other zoning district. No minimum lot width is required; however, all lots shall abut on a publicly dedicated and improved street and shall have adequate width to provide for yard space and parking areas.

- B. Side Yards

Minimum side yards shall be required so as to meet the requirements of Section 21.063 A, above.

- C. Front Yard Depth

Any structure or parking area must be located not less than 150 feet from the centerline of the road or highway on which the use has frontage.

- D. Minimum Rear Yard Depth

Minimum rear yard depth shall be required so as to meet the requirements of Section 21.063 A, above.

E. Screening

All industrial areas adjacent to residential areas shall provide a screening of shrubbery, landscaped mounds and/or fencing so as to hide trash collection areas, storage areas and service areas from the view of adjacent residential areas. All such shrubbery shall be properly trimmed and all screening shall be maintained in a neat and tidy manner.

F. Open Space

A minimum of 10% of the gross acreage shall be utilized as open space. Open Space shall be distributed throughout the development as part of a unified open space system, which shall serve to unify the development visually and functionally, and buffer surrounding land uses. Open spaces may be used for the natural disposal of storm water drainage. No features should be designed which are likely to cause erosion or flooding.

G. Building Heights

No building in this district shall exceed forty-five (45) feet.

H. Landscaping

All yards, front, rear and side, shall be landscaped. A landscape plan shall be submitted with the Final Development Plan and shall be subject to approval in the same manner required of the Final Development Plan. All landscaping used for screening purposes shall be non-deciduous. In addition, all undeveloped areas shall be regularly and adequately maintained by means of regular mowing, trimming and weed removal.

I. Signs

Signage shall conform to the provisions of this Resolution.

J. Trash and Garbage Control

All trash and garbage shall be stored in container systems which are located and enclosed so as to effectively screen them from view.

K. Freight Loading Area

When any use within this district requires the pickup or delivery of merchandise or supplies, an adequate loading area for such activity shall be provided on the lot occupied by the use. No such loading area shall be located on any public street or alley. Such loading areas, as provided, shall be adequate in size to accommodate tractor-trailer (semi) units with adequate room to permit entry to such loading area without interfering with traffic on adjacent streets or highways.

L. Parking

Off-street parking shall be paved and provided, at the time of construction of the main structure or building, with adequate provisions for ingress and egress according to the Final Development Plan. In preparing and approving the parking plan, the provisions of this Resolution shall be incorporated, or a divergence requested.

M. Exterior Lighting

All exterior lighting shall be as specifically approved as part of the Final Development Plan. Exterior lighting shall be arranged so as not to shine on adjacent properties and public streets.

N. Supplemental Conditions and Safeguards

The Zoning Commission and/or Board of Trustees may impose additional conditions relating to the development with regard to the type and extent of the public improvements to be installed; landscaping; improvements and maintenance of open space areas; and other development characteristics.

O. Divergences

The Township, as a part of the preliminary development plan and text approval, may grant divergences from any standard or requirement in this Article or contained elsewhere in this Resolution that is noted "as approved per plan." An applicant requesting a divergence from any such standard or requirement

shall specifically list each requested divergence on the development standards text submittals.

P. Other Requirements

Unless specifically supplemented by the standards contained in Article XXI, or those standards approved by divergence in the preliminary development plan and text, the development shall comply with all the Additional Zoning Requirements applicable to all zoning districts as set forth in this Resolution.

Section 21.064 Planned Industrial Performance Standards

No land or structure in the PI District shall be used or occupied in such a manner so as to create any dangerous, injurious, noxious or otherwise objectionable impact on any land which is located in any other zoning district. Such impacts shall include those related to noise, vibration, odor, dust, glare, or storm runoff. Statements in writing that such uses comply or will comply with such uses and mitigation criteria may be required by the Zoning Commission and/or Board of Trustees from the applicant. In addition to any other provisions of this Resolution, no use shall be conducted within this district which fails to maintain the following standards:

A. Fire and Explosion Hazards

All activities, including storage, involving flammable or explosive materials shall include the provision of adequate safety devices against the hazard of spill, fire and/or explosion. All standards enforced by the Occupational Safety and Health Administration shall be adhered to. Burning of waste materials in open fire is prohibited, as enforced by the Ohio Environmental Protection Agency.

B. Glare, Heat and Exterior Light

Any operation producing intense light or heat, such as high temperature processing, combustion, welding or other, shall be performed within an enclosed building and not be visible beyond any lot line bounding the property whereon the use is conducted.

C. Dust and Erosion

Dust or silt shall be minimized through landscaping or paving in such a manner as to prevent their transfer by wind or water to points off the lot in objectionable quantities.

D. Liquid or Solid Wastes

No discharge at any point into any public sewer, private sewage disposal system or stream, or into the ground, of any materials of such nature or temperature as can contaminate any water supply or interfere with bacterial processes in sewage treatment, shall be permitted. The standards of the Ohio Environmental Protection Agency shall apply.

E. Vibrations and Noise

No uses shall be located and no equipment shall be installed in such a way as to produce intense, earth-shaking vibrations which are discernible without instruments at or beyond the property line of the subject premises.

F. Odors

No use shall be operated so as to produce continuous, frequent or repetitive emission of odors or odor-causing substances in such concentrations perceptible at any point at or beyond the property on which the use is located. Standards of the Ohio Environmental Protection Agency shall be adhered to.

G. Storm water Runoff

Structures and physical changes to the site shall be designed and constructed so as to not cause an increase in storm water runoff onto adjacent properties.

H. Air Pollution

No emission of air pollutants shall be permitted which violate the Clean Air Act Amendments of 1977 or later amendments as enforced by the Ohio Environmental Protection Agency.

ARTICLE XXII

(O-R) ORIENT RESIDENTIAL DISTRICT

Section 22.01 Purpose

The O-R District is established to provide requirements of properties located in the former Village of Orient territory, which was dissolved in May 2013, and which properties are now located in the Township. It is the intent of this Article to adopt regulations so that the current uses as of the effective date of this Amendment are conforming uses. The application of this District is very limited; properties outside of the O-R District territory are not eligible to be rezoned to this District or to have any provisions of this Article applied to them. However, where applicable, properties within the O-R District may apply for rezoning to classifications relevant within the Scioto Township Zoning Code.

Section 22.02 Zoning of O-R District Territory

All territory formerly located in the Village of Orient and located in the Township at the effective date of this Amendment shall be referred to as the O-R District and immediately be subject to the O-R District zoning classification and the regulations and restrictions as set forth in this Article and this Resolution. The Official Zoning Map shall be amended to reflect the addition of the territory formerly located in the Village of Orient.

Section 22.03 Existing Structures, Uses, Outdoor Storage, and Other Conditions

A. Existing Structures and Other Existing Conditions

1. Where a lawful structure exists at the effective date of this Amendment that does not comply with the requirements of this Resolution because of restrictions such as minimum lot size, minimum lot frontage, front yard setback, side yard setbacks, rear yard setback, height, building design, screening (except for the screening requirements of subsection (C)(2) of this Section), buffering, landscaping, signage and lighting or other requirements related to the structure and other existing conditions, that structure and other existing conditions may be continued as a conforming existing structure as long as it meets the requirements of this Subsection (A).
2. Existing Structures may be extended, enlarged, altered, remodeled or modernized upon finding of the Township

Zoning Inspector that all of the following conditions are met:

- a. That the existing structure meets all height, area, and/or parking and loading provisions that were applicable immediately prior to the rezoning of the property on which it is located and that the new construction meet all the development standards for the O-R District.
 - b. That the enlargement or extension is limited to the same parcel on which the existing structure(s) is located and is owned by the same owner. The enlargement or extension may not exceed fifty percent (50%) of the ground floor area of the existing structure at the effective date of this Amendment unless a variance is granted by the Board of Zoning Appeals.
 - c. That the improvement does not interfere with the use of other properties in the vicinity.(i.e. Lighting, noise, noxious odors)
3. Any existing structure that does not have the minimum number of parking or loading areas required by this Resolution, and which thereafter provides additional parking and/or loading spaces in conjunction with an improvement as permitted under the Resolution, shall be required to meet the minimum number of parking spaces or loading areas as required by the O-R District.
4. Reconstruction
- a. Should less than sixty percent (60%) of an existing structure exclusive of foundation be destroyed by an act of God, or other action outside the control of the owner/lessee, that existing structure may be reconstructed as it existed prior to the action causing its destruction.
 - b. Any permitted reconstruction shall be started within twenty-four (24) months of destruction and be continued until completed or the applicant shall comply with the applicable use and development standards of this Resolution.(Article IV Section 4.06)
 - c. Should the property/building owner or lessee demolish more than fifty percent (50%) of the gross square footage of an existing structure, then all of the improvements on the property must be constructed and meet the requirements of the O-R District and this Resolution.

B. Existing Uses

The long-range implementation of this Resolution requires sensitive treatment of existing uses currently located in the O-R District and previously located in the Village of Orient. It is the intent of this article to permit existing uses to continue and to be considered conforming to this Resolution, even if the use is not otherwise permitted in this District unless the current use can

conform to current township zoning. The following provisions must also be met:

1. Subject to the provision of paragraph 3 below, a property that is in use at the effective date of this Amendment shall continue to be allowed as permitted on the property in addition to the permitted uses applicable in this O-R District, provided that at least one of the permitted uses under the prior zoning has been operated in an Existing Structure or on the lot of the property within twenty-four (24) months prior to the rezoning of the property into this district. Such a use shall be known as an “Existing Use.”
2. In addition to the provisions of paragraph 1, above, any Existing Use may be extended throughout any building or parts of a building or on the lot which were manifestly arranged or designed for that use at the time of adoption or amendment of this Resolution, but the use shall not be extended to occupy any land outside the building except as permitted under the Existing Structures Subsection (A) (2) above.
3. Any use which existed in the “O-R District” at the effective date of this Amendment shall be considered an Existing Use and shall be permitted under this District.
4. Abandonment of an Existing Use
 - a. If an Existing Use is abandoned for any reason for a period of more than twenty-four (24) months, any subsequent use shall conform to the requirements of this Resolution. With regard to a multi-tenant building, the term “Existing Use” shall mean all of the existing uses in that building.
 - b. An existing use shall be determined by the Zoning Inspector to be abandoned if one or more of the following conditions exist: utilities, such as water, gas and electricity to the property, have been disconnected; the property, buildings, and grounds, have fallen into disrepair; signs or other indications of the presence of the use have been removed; equipment of fixtures necessary for the operation of the use have been removed; other actions, which in the opinion of the Zoning Inspector constitute an intention on the part of the property owner or lessee to abandon the use.
5. Existing residential uses at the time of the adoption of this Article shall be permitted. However, expansions of single family dwellings to multi family are subject to rezoning procedure.

C. Existing Residential Outdoor Storage

The long range implementation of this Amendment requires sensitive treatment of existing residential outdoor storage facilities in the O-R District, and previously located in the Village of Orient. It is the intent of this section to permit existing residential outdoor storage to continue and to be considered conforming to this Resolution, provided that all of the following requirements are met:

1. Any property that is actively using existing residential outdoor storage at the effective date of this Amendment shall continue to be allowed as temporarily permitted so that the lessee/owner can comply with the requirements of Subsection (C)(2), below.
2. All outdoor storage areas shall comply with the Screening and Buffering requirements of Article XXIX within one (1) year of the effective date of this Amendment. Compliance shall be evidenced by the issuance of a Certificate of Zoning Compliance for residential outdoor storage.

Section 22.04 Permitted Uses

- A. One single-family detached dwellings.
- B. Limited home occupations, subject to the requirements of Section 29.02 of this Resolution.
- C. Child day care type B home.
- D.

Section 22.05 Accessory Uses

- A. Accessory buildings or structures customarily associated with residential use, including detached garages or carports, tool or garden sheds, playhouses, swimming pools, tennis courts and similar facilities for primary use by occupants of the principal use of the property on which the facility is located, subject to the requirements of Article XXIX of this Resolution.

Section 22.06 Conditional Uses

- A. Expanded home occupations as provided in Section 29.02 of the Resolution.
- B. Accessory Apartment (Granny Flat), subject to the requirements of Section 13.05 C of this Resolution.
- C.

Section 22.07 Applicability

Except for the O-R District territory as it existed on May 8, 2013, the O-R District shall not be extended to or apply to any other territory or area.

Section 22.08 Development Standards

A. Residential Lots

For lots existing at the time of the adoption of this Article, the following development standards apply:

1. Minimum Lot Width: For each principal use there shall be lot width of not less than fifty (50) feet with continuous frontage on a publically dedicated, improved street or highway. Minimum lot width on a curved street shall be fifty (50) feet. In addition, lot width shall be sufficient to maintain a lot depth-to-width ratio of not greater than 3.5:1.
2. Maximum Principal Building Height: Forty five (45) feet.
3. Minimum Front Yard Depth: Thirty (30) feet from the centerline of any county or township road. Sixty (60) feet from the centerline of any federal or state highway. If lot is adjacent to developed residential lots, front yard depth can be no closer to centerline of road than adjacent residence.
4. Minimum Side Yard Width: Eight (8) feet on each side.
5. Minimum Rear Yard Depth: Twenty five (25) feet.
6. Minimum Building Area: Twelve hundred (1200) square feet.
- 7.

B. Parking:

For permitted and conditional uses, outside of enclosed structures, parking spaces shall be provided for two (2) vehicles for each dwelling unit. Required parking spaces shall not be provided on public or private streets within and on the perimeter of the community. Parking spaces utilized at the adoption of this amendment may continue until change of use of the lot or structure then must adhere to the applicable zoning district in Article XXX. Parking shall be so arranged that there is no maneuvering incidental to parking in the travel lane of streets.

C. Trash and Garbage Control

All trash and garbage shall be stored in container systems which are located and/or enclosed so as to effectively screen them from view. The disposal of trash and maintenance of the area shall be the responsibility of the owner of the property.

D. Signs

Signs and signage shall comply with the provisions of Article XXXI of the Resolution.

E. General Development Requirements

Unless provided otherwise, all Permitted, Conditional, and Accessory Uses shall comply with the General Development Requirements provided in Article XXVIII of the Resolution.

ARTICLE XXIII

(SU) SPECIAL USE DISTRICT

Section 23.01 Purpose

The SU District is established to provide for suitable locations for particular uses which, by their nature, are likely to have significant and/or unique impacts on adjacent and nearby property. The procedures specified for the SU District are intended to promote the compatibility of the use with adjoining residential uses and to ensure that the location of such facilities will provide for adequate and efficient access and service provision. Once a Development Plan is approved pursuant to the procedures governing the submission of a Zoning Amendment request to the SU District, that Development Plan and all uses, buildings and structures approved in connection therewith may not be substantially changed, added to, or otherwise altered unless approved in accordance with Article VI of this Resolution.

Section 23.02 Permitted Uses

Buildings and land within the SU District shall be utilized only for uses set forth in the following schedule:

<u>PRIMARY BUILDINGS AND USES</u>	<u>ACCESSORY USES</u>
1. Community buildings, meeting halls, libraries, museums, and similar places for public assembly.	Signage, parking areas.
2. Primary or secondary public, private, private parochial schools.	Parking areas, signs, playfields/playgrounds, stadiums.
3. Churches and places of public worship.	Signage and parking areas.
4. Cemeteries, including mausoleums.	Signage.
5. Prisons and other correctional facilities.	Signage, parking areas.
6. Commercial facilities such as stadiums, amphitheaters, racetracks or similar facilities for conducting sporting events, concerts, and similar outdoor events.	Parking areas, administrative and maintenance structures.
7. Commercial recreational areas such as golf courses, gun clubs, sportsmen's clubs, summer camps and similar uses.	Parking areas, maintenance structures.

Section 23.03 Procedures

The procedures to be followed in placing land in the (SU) Special Use District shall comply with those specified in Article VI of this Resolution, with the following additions:

23.03.01 Application

The owner or owners of a tract of land may request that the Official Zoning Map be amended to include such lands as a Special Use District. The applicants are encouraged to meet with the Township Zoning Commission prior to submittal of the application to familiarize themselves with the requirements for this district.

23.03.02 Development Plan

In addition to the material required for the application for a zoning amendment, as specified in Article VI of this Resolution, fifteen (15) copies of a Development Plan shall be submitted for land proposed to be zoned into the SU District. Such development plan shall contain, in text and map form, the following information:

- A. A survey map of the boundaries of the area requested for zoning map amendment.
- B. A site plan drawn to scale showing the specific location of all existing and proposed buildings, setbacks and yards, topographic contours and surface drainage, existing and proposed vegetation and landscaping, and other prominent physical features.
- C. Specific uses to be permitted within the proposed development, specified according to area or specific building location. An explanation of how these uses shall be designed or activities carried out, so as to create desired compatibility with adjacent land uses.
- D. Existing roads and drives, anticipated traffic impacts and methods to be employed to address adverse impacts.
- E. A list of the specific restrictions proposed by the applicant for zoning map amendment which are designed to fulfill the concept proposed and ensure compatibility of the project with the surrounding area. Such restrictions shall become part of the conditions on which any approval is given.
- F. Architectural design and exterior construction material criteria for all structures.
- G. Building heights and dimensions.
- H. Signage
- I. The proposed provisions for water, sanitary sewer, waste disposal, surface drainage with engineering feasibility studies or other evidence of reasonableness.

- J. The proposed traffic patterns showing public and private streets and other transportation facilities, including their relationship to existing conditions, topographically and otherwise.
- K. The relationship of the proposed development to existing and probable uses of surrounding areas during and after the development timetable.
- L. Location of schools, parks and other facility sites, if any, on the tract.
- M. The proposed time schedule for development of the site including streets, buildings, utilities and other facilities.
- N. If the proposed timetable for development includes developing the land in phases, all phases to be developed after the first, which in no event shall be less than five (5) acres or the whole tract (whichever is smaller), shall be fully described in textual form in a manner calculated to give Township Officials definitive guidelines for approval of future phases.
- O. The ability of the applicant to carry forth its Plan by control of the land and the engineering feasibility of the Plan.
- P. Specific statements of divergence from the development standards established in this article or in other articles of this Resolution and the justification therefore. Unless a variation from those development standards is specifically requested and approved, the same shall be complied with.

23.03.03 Criteria for Approval

In acting on the proposed application pursuant to Sections 6.06 and 6.08 of this Resolution, the Zoning Commission and the Board of Township Trustees may approve an application requesting that property be included in the SU District, provided they determine:

- A. That the proposed development is consistent in all aspects with the purpose, criteria, intent, and standards of this Zoning Resolution.
- B. That the proposed development is in conformity with the comprehensive plan or portion thereof as it may apply.
- C. That the proposed development promotes the health, safety, and general welfare of the Township and immediate vicinity.
- D. That the proposed plan meets all of the design features required in this Resolution.
- E. That the proposed development is consistent with the existing land use character and development potential of the area.
- F. That the proposed development will be compatible in use and appearance with surrounding land uses.
- G. That the development promotes greater efficiency in providing public utility services and encouraging innovation in the planning and building of all types of development.
- H. That the benefits, improved arrangement and the design of the proposed development justify the deviation from any requirements of this Resolution.

23.03.04 Effect of Approval

- A. The Development Plan as approved by the Board of Trustees shall constitute an amendment to the Resolution as it applies to the specific land in question, thereby rezoning the subject tract to the SU District

and permitting development and use of said land and any structures thereon only in accordance with the Development Plan as approved.

- B. The approval of a Development Plan shall be effective for a period of two (2) years, or for such other period as approved per plan, in order to allow for the filing and recording of a subdivision plat, if required by applicable law, and the commencement of construction of improvements on the site.

No zoning amendment passed during the established approval period shall affect the terms under which approval of the Development Plan was granted. If the required subdivision plat has not been approved and recorded, and construction commenced within the established approval period, then the Development Plan shall expire unless the Board of Trustees has approved an extension of this time limit. Absent such an extension, no use shall be established or changed and no building, structure or improvement shall be constructed until a new final development has been filed with and approved by the Township, and such application for approval, shall be subject to the same procedures and conditions as an original application for Development Plan approval.

This new application shall comply with the terms of the Zoning Resolution then in effect at the time of filing, including, without limitation, any zoning amendments enacted from and after the date of the initial request to include the property within the SU District. In addition, the Township may initiate a zoning amendment to rezone the property to its former classification at expiration of the Development Plan.

- C. If a plat is required by applicable law, no use shall be established or changed, and no building, structure, or improvement shall be constructed or altered until the required subdivision plat has been prepared and recorded in accordance with the Subdivision Regulations for Pickaway County, Ohio, and this Resolution. The subdivision plat shall be in accordance with the approved Development Plan and shall be recorded within two (2) years after the approval of the Development Plan or within such other period as may be approved per plan.
- D. All plats, construction drawings, restrictive covenants and other necessary documents shall be submitted to the Zoning Inspector or the Inspector's designated technical advisors for administrative review to ensure compliance with the Development Plan as approved.

Section 23.04 Extension of Time/Modification of Development Plan

- A. An extension of the time limit for either recording the required subdivision plat, or enlarging the approval period for a Development Plan may be granted by the Board of Trustees, provided the Board of Trustees finds that such an extension is not in conflict with the public interest, that there is a legitimate purpose and necessity for such extension, and that the applicant shows evidence of a reasonable effort toward the accomplishment of the filing and/or recordation of the plat and the completion of the development of the project. A request for extension shall be filed prior to the expiration of the established approval period.

Prior to rendering a decision on the request, the Board of Trustees may refer the request to the Zoning Commission for its recommendation.

- B. In the case of a request for a modification or amendment to the Development Plan, said modification or amendment shall be subject to the same procedure and conditions of approval as the original application.

Section 23.05 Development Standards

A. Lot and Area Requirements

The area or parcel of land for a special use shall not be less than that required to provide space adequate for off-street parking areas, yards and open spaces sufficient to maintain the character of the neighborhood. The size of the parcel of land occupied by the proposed use, and all setbacks, shall be shown on the Development Plan required in Section 23.03.

B. Front Yard

The front yard setback shall be not less than the largest required front yard setback for any adjacent zoning district.

C. Side and Rear Yards

Where any special use abuts a district where residences are a permitted use, a side and a rear yard of not less than fifty (50) feet shall be maintained. In addition, a landscaped buffer shall be installed in such yard. The minimum dimension of yards abutting other districts shall be as set forth in the approved Development Plan.

D. Open Space

Open space shall be distributed throughout the development as part of a unified open space system, which shall serve to unify the development visually and functionally, and buffer surrounding land uses. Open spaces may be used for the natural disposal of storm water drainage. No features should be designed which may cause erosion or flooding.

E. Building Heights

No building within this district shall exceed forty (40) feet in height.

F. Landscaping

All yards, front, rear and side, shall be landscaped. A landscape plan shall be submitted with the Development Plan and shall be subject to approval in the same manner required of the Development Plan. All landscaping used for screening purposes shall be non-deciduous. In addition, all undeveloped areas shall be adequately and regularly maintained by means of regular mowing, trimming and weed removal.

G. Signs

Signage shall conform to the provisions of this Resolution.

H. Trash and Garbage Control

All trash and garbage shall be stored in container systems which are located and enclosed so as to effectively screen them from view.

I. Parking

Off-street parking shall be paved and provided, at the time of construction of the main structure or building, with adequate provisions for ingress and egress according to the Development Plan. In preparing and approving the parking plan, the provisions of this Resolution shall be incorporated, or a divergence requested.

J. Exterior Lighting

All exterior lighting shall be as specifically approved as part of the Development Plan. Exterior lighting shall be arranged so as not to shine on adjacent properties.

K. Supplemental Conditions and Safeguards

The Zoning Commission and/or Board of Trustees may impose additional conditions relating to the development with regard to the type and extent of the public improvements to be installed; landscaping; improvements and maintenance of open space areas; and other development characteristics.

L. Divergences

The Township, as a part of the Development Plan approval, may grant divergences from any standard or requirement in this Article or contained elsewhere in this Resolution that is noted "as approved per plan." An applicant requesting a divergence from any such standard or requirement shall specifically list each requested divergence on the Development Plan submittals.

Section 23.06 Performance Standards

No land or structure in the SU District shall be used or occupied in such a manner so as to create any dangerous, injurious, noxious or otherwise objectionable impact on any land which is located in any other zoning district. Such impacts shall include those related to noise, vibration, odor, dust, glare, or storm runoff. Statements in writing that such uses comply or will comply with such uses and mitigation criteria as may be required by the Zoning Commission from the applicant. In addition to any other provisions of this Resolution, no use shall be conducted within this district which fails to maintain the following standards:

A. Noise

The sound pressure level of any operation on a lot within the SU District shall not exceed the average intensity of traffic noise in the nearest residential districts, and no sound shall be objectionable due to intermittence, beat frequency or shrillness.

B. Vibration

No vibrations which are perceptible without the aid of instruments shall be permitted, as measured on the boundary of the property in the SU District.

C. Odor

No emission of odorous matter in any quantities so as to produce a public nuisance shall be permitted, as measured on the boundary of the property in the SU District.

D. Dust and Smoke

The emission of smoke, soot, fly ash, fumes, dust or other types of pollutants borne by the wind shall be controlled so that the rate of emission and quantity deposited do not create a public nuisance, as measured on the boundary of the property in the SU District.

E. Glare

Exterior lighting shall be used in a manner that produces no glare on public highways or adjacent land.

F. Storm Runoff

Structures and physical changes to the site shall be designed and constructed so as to not cause a significant increase in storm water runoff onto adjacent properties.

ARTICLE XXIV

(FP) FLOOD PLAIN OVERLAY DISTRICT

Section 24.01 Finding of Fact

Specific areas adjacent to streams and watercourses within Scioto Township are subject to periodic inundation which may result in loss of life and property, hazards to health and safety, disruption of commerce, and extraordinary public expenditures for flood protection and relief, all of which adversely affect the public health, safety, and general welfare. These flood losses are caused by the occupancy of flood hazard areas by unsuitable land uses, and the cumulative effect of obstructions in flood plains, causing increased flood heights and velocities.

Section 24.02 Purpose

It is the purpose of this Article to promote the public health, safety and general welfare and to minimize losses resulting from periodic inundation of flood waters in Scioto Township by:

- A. Restricting or prohibiting uses and activities that are dangerous to health, safety or property in times of flooding, or cause excessive increases in flood heights or velocities;
- B. Controlling the filling, grading, dredging and other development which may increase flood damage; and
- C. Controlling the alteration of natural flood plains, stream channels, and natural protective barriers which are involved in the accommodation of flood waters.

Section 24.03 Scope and Application

24.03.01 Applicable Lands

This Article shall apply to all lands within Scioto Township shown as within the 100 year flood boundary as identified by the Federal Emergency Management Agency on the Flood Insurance Rate Map Numbers and dates as follows:

39129C0155H	(September 30, 1999)
39129C0050H	(September 30, 1999)
39129C0025H	(September 30, 1999)
39129C0150H	(September 30, 1999)
39129C0175H	(September 30, 1999)

The Flood Insurance Rate Maps with accompanying Flood Insurance Study and any subsequent revisions to the above maps are hereby adopted by reference and declared to be a part of this Article.

24.03.02 Overlay District Designation

The areas of special flood hazard identified on the Official Zoning District Map shall be considered as an overlay district. This overlay district shall be designated as the Flood Plain Overlay (FP) District.

The Flood Plain Overlay (FP) District shall be superimposed over the Official Zoning District Map. The underlying zoning district, as shown on the Official Zoning District Map, shall hereafter be called the base district. Uses and minimum requirements shall be determined by the base district; however, when the requirements governing the Flood Plain Overlay District are more restrictive than those of the base district, the provisions of this Article shall supersede those of the base district.

24.03.03 Interpretation of Boundaries

When disagreement exists as to the boundaries of the Flood Plain Overlay District, those boundaries shall be interpreted to be the boundaries as shown on the Flood Insurance Rate Maps referenced in Section 24.03.01.

Actual boundaries may also be determined by use of the flood elevation profile information provided in the referenced Flood Insurance Study or Studies and topographic survey of the site in question.

24.03.04 Warning and Disclaimer of Responsibility

The degree of flood protection required by this Article is considered reasonable for regulatory purposes. Larger floods may occur or flood heights may be increased by man-made or natural causes, such as ice jams and bridge openings restricted by debris. This Article does not imply that areas outside the Flood Plain Overlay District boundaries or land uses permitted within such district will be free from flooding or flood damage. This Article shall not create liability on the part of Scioto Township or any officer or employee thereof for any flood damages that result from reliance on this Article or any administrative decision lawfully made thereunder.

Section 24.04 Development Standards

- A. Open space uses shall be permitted within the FP District to the extent that they are allowed as permitted, accessory or conditional uses in the base zoning district and provided those uses do not require structures, fill or the storage of material or equipment.

- B. No structure shall be permitted within the flood plain and no use shall be established which would unduly restrict the capacity of the channel or floodway of the main stream, its tributaries or drainage facilities.

- C. No grading or filling within the FP District shall be permitted unless it is demonstrated to the Board of Zoning Appeals, by hydrologic and hydraulic analysis prepared by a Professional Engineer registered in the State of Ohio, that the cumulative effect of the proposed activities shall not increase the water surface elevation of the base flood more than one (1) foot at any point. In acting on such a proposal, the Board shall seek the input of the Pickaway Soil and Water Conservation District.

ARTICLE XXV

(RESERVED FOR FUTURE USE)

ARTICLE XXVI

(DCC) DARBY CREEK CONSERVATION DISTRICT

Section 26.01 Findings of Fact

Big Darby Creek forms the western boundary of Scioto Township. Portions of this stream were designated a component of the National Wild and Scenic Rivers system on March 10, 1994, by the U.S. Secretary of the Interior and were also designated as an Ohio Scenic River. The stream and its watershed contain an extraordinary array of wildlife, including 86 species of fish, 40 species of mussels, 176 species of birds, 34 species of mammals as well as more than one dozen rare plant species. It is considered by the Ohio Environmental Protection Agency (OEPA) as an exceptional warm water habitat, due in part to the stability of the water temperature afforded by the dense tree canopy along its banks and its clear and unpolluted waters. In recognition of these facts, the Board of Scioto Township Trustees declares the preservation and conservation of this unique environment to be within the public interest.

Section 26.02 Purpose

It is the purpose of this district to limit inappropriate land uses adjacent to the Big Darby Creek, preserve the high water quality and free flowing conditions of the streams, maintain natural water temperatures, preserve plant and animal habitat, and prevent stream bank erosion and siltation.

Section 26.03 Boundaries

The Darby Creek Conservation (DCC) District shall consist of an area two-hundred (200) feet from and parallel to the ordinary high water mark along the eastern bank of the Big Darby Creek away from the creek landward to a line parallel to the ordinary high water mark in Scioto Township, Pickaway County, Ohio.

The "*ordinary high water mark*" is defined as the line between upland and bottomland which persists through successive changes in water level, below which the presence and action of the water is so common or recurrent that the character of the land is marked distinctly from the upland, and is apparent in the soil itself and/or the configuration of the surface of the soil and vegetation.

Section 26.04 Permitted Uses

- A. Passive private or public recreational uses such as fishing, walking, bird watching, etc. (No public easement over such property is hereby created).

- B. Selective harvesting of timber, provided not more than twenty-five percent (25%) of the tree crown cover within the portion of the particular land owner's parcel within the DCC District is removed and trees on the immediate stream bank are not harvested, unless a specific silviculture plan for the property is submitted to and approved by the Pickaway County Soil and Water Conservation District. Damaged or diseased trees may be removed. The stump and roots of trees on the stream bank shall be left in place to prevent erosion.
- C. Agriculture on lots greater than five (5) acres, pursuant to Ohio Revised Code Section 519.21.

Section 26.05 Development Standards

- A. No new structural or surficial (pavement) construction of any kind shall be permitted, with the exception of fences running perpendicular to the stream bank, when used for the containment of livestock.
- B. No discharge is permitted into any public or private sewer, drain, tile or stream, or onto the ground of any liquids or materials which, because of their toxic properties or temperatures when discharged, would contaminate the Big Darby watershed, groundwater or stream. The Ohio Environmental Protection Agency (OEPA) standards shall apply and be met in making a determination as to the propriety of the discharge. Discharges expressly permitted by the Pickaway County Board of Health and/or OEPA are not restricted by this Section.
- C. No drilling, dredging or dumping of soil, spoil, liquid or solid material shall be permitted.
- D. The natural vegetation within the Darby Creek Conservation District shall remain undisturbed except for the removal of noxious weeds as otherwise permitted under the Ohio Revised Code Chapters 5579 and 5589, subject to the activities referenced above in Section 26.04(B).
- E. In addition to the standards above, the requirements of the Flood Plain Overlay (FP) District shall apply.

ARTICLE XXVII

(ANO) AIRPORT NOISE OVERLAY DISTRICT

Section 27.01 Finding of Fact

As part of the Federal Aviation Administration plan to reduce incompatible land uses around airports, a Part 150 Airport Noise Study has been completed for Rickenbacker International Airport to determine those adversely affected by airport noise. Portions of the geographic area so identified are located within Scioto Township.

Section 27.02 Purpose

It is the purpose of the ANO District to inform property owners of the existence of the potential noise impacts in particular areas within Scioto Township, and to promote land use patterns and development practices that are appropriate for such areas.

Section 27.03 Overlay District Designation

The ANO District is an overlay district. When land is proposed to be developed within the boundaries of the Airport Noise Overlay District, such development shall meet the requirements of the underlying district as well as the requirements of this Article.

Section 27.04 Definitions

For the purposes of this Article, the following terms, phrases and/or words shall have the following meanings:

- A. "Day-Night Sound Level (Ldn)" means a cumulative aircraft noise index which estimates the exposure of an area to aircraft noise and relates the estimated exposure to an expected community response. The Day-night sound level noise metric assesses a ten decibel (10 dB) penalty to all noise events occurring between 10:00 pm and 7:00 am.
- B. "Ldn Contour" means a line linking together points of equal cumulative noise exposure based on the Ldn metric. Such contours are developed by a computer model based on aircraft flight patterns, number of daily aircraft operations by type of aircraft and time of day, noise characteristics of each aircraft and typical runway usage patterns.

Section 27.05 Boundaries

The Airport Noise Overlay District shall consist of those areas identified as within the 65 Ldn and greater Ldn contours as recommended for protection in the Part 150 Noise Study for Rickenbacker Airport, as may be subsequently amended.

Section 27.06 Development Standards

A. Permitted Uses

Uses permitted in the underlying base district shall be permitted in the ANO District.

B. Notification of Noise Impacts

Applications for zoning certificates for development of land in the ANO District shall contain a statement by the applicant that he/she is aware that the property may be subject to aircraft over flight and elevated noise impacts.

C. Noise Mitigation

The owners and/or developers of property within the ANO District are encouraged to implement methods in the construction of buildings or structures to reduce interior noise levels.

PART FOUR

ADDITIONAL ZONING REQUIREMENTS

ARTICLE XXVIII

GENERAL DEVELOPMENT REQUIREMENTS

Section 28.01 Lot Width

A. Frontage Required

No building, structure, or improvement shall be constructed or altered, nor any new lot be established, unless such lot fronts on a publicly dedicated and improved road within the Township.

B. Lot Width

Lot width shall be measured along the front lot line that abuts such road as designated in Section 28.01A above.

Section 28.02 Front Yards

A. Front Yard Requirements

All front yard space shall be maintained in a neat and orderly state and be kept free of any trash, junk or debris.

B. Front Yard Measurements

Front yard depth shall be measured from the centerline of the adjacent highway or road to the building line, unless otherwise indicated in this Resolution.

C. Corner Lots

In the event any principal or accessory building or structure is to be constructed on a corner lot, the front yard setback shall be required from both roads.

In the event any such building or structure is to be located near a curve or bend in any road, said building or structure may not be closer to the road at any point than the setback requirement for that road.

Section 28.03 Side Yards

- A. Measurement
Side yard width shall be measured from the nearest side lot line to the building line.
- B. Open Porches and Architectural Features
In a residential district, all portions of the structure, including open, uncovered porches, terraces or cornices, canopies, eaves, pilasters, sills or other similar architectural features shall be located behind the line as established by the front, rear and side yard setback in that district.

Section 28.04 Rear Yards

- A. Measurement
Rear yard depth shall be measured from the rear lot line to the building line. Where a lot abuts a service street or alley, the rear yard shall be measured from the right-of-way line of the existing street or alley.
- B. Accessory Uses or Structures
Accessory uses or structures may be allowed in a rear yard, subject to requirements of Article XXIX of this Resolution.

Section 28.05 Height

Unless otherwise provided elsewhere in this Resolution, height regulations specified in the various zoning districts shall not apply to chimneys, tanks, cupolas, domes, spires, private radio or television antennae or similar structures attached to a primary structure.

Section 28.06 Trash, Refuse and Debris

The storage or accumulation of trash, garbage, refuse and other debris (including, without limitation, discarded household goods, discarded commercial products, discarded building materials, discarded industrial by-products, discarded brush and other vegetation and other similar materials) shall be a nuisance per se and shall be prohibited in all zoning districts, excepting trash, garbage, refuse and debris that is completely enclosed within an appropriate container and placed at an assigned location for regularly scheduled pick-up. In all cases, there shall be full compliance with all applicable zoning district standards.

Section 28.07 Municipal Waste Storage

No impoundment area or storage vessel (tank) shall be constructed or used to store municipal waste of any kind including, but not limited to: sewage, industrial waste, human waste, chemical waste, hospital waste or other hazardous waste treated or untreated in a residential, business or agricultural district.

This prohibition shall not apply to sanitary units approved by the Pickaway Board of Health nor shall it apply to animal waste generated by agricultural production.

ARTICLE XXIX

ACCESSORY USES AND STRUCTURES

Section 29.01 Regulation of Agriculture on Specific Lots

Subject to the provisions of Section 29.01 A, below, with respect to lots greater than five (5) acres of land, nothing contained in this Resolution shall prohibit the use of any such land for agriculture purposes, or the construction or use of buildings or structures incident to the use for agricultural purposes of the land on which such buildings or structures are located, and no zoning certificate shall be required for any such use, building or structure.

- A. In any platted subdivision approved under Ohio Revised Code Sections 711.05, 711.09, or 711.10, or in any area consisting of fifteen (15) or more lots approved under Section 711.131 of the Ohio Revised Code that are contiguous to one another, or some of which are contiguous to one another and adjacent to one side of a dedicated public road, and the balance of which are contiguous to one another and adjacent to the opposite side of the same dedicated public road, agriculture shall be regulated as follows:
1. Agriculture is prohibited on lots of one acre or less.
 2. Buildings or structures incident to the use of land for agriculture purposes on lots greater than one (1) acre but not greater than five (5) acres must conform to the setbacks, size and height requirements for the underlying zoning district. Subject to subsection 3 c) below, agriculture is permitted on lots greater than one (1) acre but not greater than five (5) acres.
 3. Dairying and animal and poultry husbandry are permitted on lots greater than one acre but not greater than five acres until thirty-five percent of the lots in the subdivision are developed with at least one building, structure, or improvement that is subject to real property taxation or that is subject to the tax on manufactured and mobile homes under Section 4503.06 of the Ohio Revised Code. All dairying and animal and poultry husbandry uses shall be setback from all adjoining property lines at least 20 feet. All buildings or structures intended to house livestock shall be located at least 50 feet from any side lot line and 25 feet from any rear lot line. After thirty-five percent of the lots in the subdivision are so developed, ongoing dairying, animal and poultry husbandry shall be considered a nonconforming use pursuant to Section 519.19 of the Ohio Revised Code and Article 4 of this Resolution. Dairying, poultry, and animal husbandry shall be prohibited on such lots after thirty-five percent of the lots are so developed.
- B. Farm markets that derive at least fifty percent of their gross income from produce raised on farms owned or operated by the market owner in a normal crop year are permitted in any zoning district, subject to the following regulations:

1. Buildings less than 144 square feet shall be placed at least 15 feet outside the road right of way so as to safely allow for adequate customer off street parking. Seasonal farm markets may use grassed areas for parking. Permanent farm markets shall be paved or graveled parking.
2. For buildings larger than 144 square feet, off street parking shall be provided at the ratio of one space for each 150 square feet of farm market. Seasonal parking may be grassed areas, but permanent parking shall be graveled or paved and provided egress in accordance with the recommendation of the Scioto Township Zoning Inspector and shall obtain a driveway permit from the Scioto Township Road Department. Setbacks are the same as for any principal structure in the underlying zoning district.

Section 29.02 Home Occupations

"Home occupation" means an activity, profession, occupation, service, craft, or revenue-producing hobby which is clearly incidental and subordinate to and customarily associated with the use of the premises as a dwelling, and is conducted by the residents thereof entirely within the dwelling unit, or elsewhere on the premises without any significant adverse impact upon surrounding properties. Home occupations shall be regulated as accessory or conditional uses in the various residential districts. A home occupation is classified as follows:

- A. **Limited Home Occupation:** a limited home occupation may, upon the issuance of a zoning certificate, be permitted to be conducted as an accessory use within a dwelling unit in designated residential zoning districts, provided that the following requirements are met:
 1. The use shall be clearly incidental and secondary to the use of the dwelling for residential occupancy.
 2. The use shall be conducted entirely within the dwelling and shall not occupy more than twenty percent (20%) of the floor area of the dwelling unit or two hundred (200) square feet, whichever is larger.
 3. The appearance of the dwelling shall not be altered and the limited home occupation within the dwelling shall not be conducted in a manner that would cause the premises to differ from its residential character either by the use of colors, materials, construction, lighting, or unauthorized signs. Other than a permitted sign, there shall be no outward appearance of any business use.
 4. No person, other than those residing on the premises, shall be engaged in such occupation.
 5. No equipment or process shall be used in such occupation which creates noise, vibration, glare, fumes, odors, or electrical interference detectable to the normal senses off the lot. In the case of electrical interference, no equipment or process shall be used which creates visual or audible interference in any radio or television receivers, computers, wireless phones or hand held wireless transmitting devices off premises, or causes fluctuations in line voltage off premises.
 6. One (1) sign not more than three (3) square feet on (1) side shall be permitted. The sign may be flatly affixed against the surface of the

- dwelling, or erected on a pole no more than five (5) feet tall in front yard. No sign illumination is permitted.
7. There shall be no outside storage of any kind. No limited home occupation shall be conducted in any accessory building or structure.
 8. Specialized instruction or tutoring shall be limited to one (1) individual at a time.
 9. No traffic shall be generated in substantially greater volumes than would be generated by a single family home.

B. Expanded Home Occupation: An expanded home occupation is provided in recognition that there may be home occupations which do not qualify as a limited home occupation but which may be appropriate within residential zoning district provided that additional standards are addressed through the conditional use permit procedure. An expanded home occupation may, if approved as a conditional use in residential zoning districts, be allowed, provided it complies with all conditional use procedures and criteria and meets the following requirements:

1. The home occupation shall be carried on solely within the confines of the dwelling unit and/or architecturally compatible accessory buildings which are customarily associated with the residential use and character of the neighborhood.
2. The home occupation shall be carried on by the individual(s) residing within the dwelling unit and there shall be no more than a total of one (1) non-resident employee.
3. Sales of commodities or services produced on the premises may be permitted, provided such commodities or services are specified and approved as a part of the application. Examples of possible expanded home occupation conditional use services or commodity sales:
 - a. Insurance or real estate sales, word processing, Internet web hosting.
 - b. Arts, crafts or other artistic instruction with united sales of associated materials used in the instruction and preparation of artistic works.
 - c. Small machinery and equipment repair such as computers, cameras, clocks or other similar small items including the limited sales of repaired or associated parts and equipment.
 - d. Limited, seasonal sales of specialized items such as holiday ornaments, handicrafts, or sporting supplies.
4. Organized instruction may be permitted provided the class size does not exceed six (6) pupils at any given time. Prior to any approval for organized instruction associated with an expanded home occupation conditional use permit, the Board of Zoning Appeals shall determine that because of the location and orientation of the residence and lot in question, the regularly organized instruction of up to six (6) pupils at any given time will not become a detriment to the existing residential character of the lot or the general area through an increase in traffic, street parking, or other factors resulting in an adverse impact as determined by the Board of Zoning Appeals.

5. No outside storage of any kind associated with an expanded home occupation shall be permitted unless it is totally screened from the adjacent residential lots and the abutting street.
6. One (1) sign not more than three (3) square feet on one (1) side and not more than five (5) feet in height above grade of the surrounding yard, may be erected advertising the expanded home occupation. The sign may be mounted flat against a building or on a five-foot pole in the front yard. The sign shall be of a design compatible with the residential character and shall not be animated or lighted.
7. All parking demands created by the conduct of an expanded home occupation shall be met off the street and other than in a front yard. Off-street parking may be permitted in a side yard or rear yard, but shall not be located any closer to the street than the required setback line. The required number of off-street parking spaces shall be equal to the spaces required for the residential use plus those required for the most similar commercial use which constitutes the home occupation.
8. No equipment, process, or storage associated with the expanded home occupation shall create odors, noise, vibration, glare, electrical interference or other nuisance detectable to normal senses off the lot. All activities, materials and equipment associated with the business shall be totally maintained within a building. In the case of electrical interference, no equipment or process shall create visual or audible interference in any radio or television receivers, computers, hand held wireless devices or other audio appliances used off the premises, or cause fluctuation in line voltage off the premises. No equipment, process, or storage associated with an expanded home occupation shall create any fire or explosion hazard, or involve the storage or use of hazardous materials in any concentration greater than that which would normally be found in a dwelling containing no home occupation.
9. Waste materials, solid or liquid, shall not be created on the premises at a level greater than normal to the residential use, unless provisions for the disposition of said wastes are acceptable to the Pickaway County Department of Health and do not create a burden on adjoining property.
10. No activity shall be conducted or permitted which creates a nuisance to neighboring properties.
11. The use of the dwelling unit for the home occupation shall be clearly incidental and subordinate to its use for residential purposes by its occupants and not more than twenty percent (20%) of the floor area of the dwelling unit or 200 feet, whichever is larger, shall be used in the conduct of the expanded home occupation. If conducted within an accessory building, no more than fifty percent (50%) of the floor space or 400 square feet, whichever is smaller, may be utilized for the expanded home occupation.
12. Unless otherwise provided by the Board of Zoning Appeals, the expanded home occupation conditional use permit shall cease to be valid and terminates once the dwelling unit used for the expanded home occupation is no longer occupied by the applicant.

Section 29.03 Accessory Structures

A. Location (Revised effective 6/3/2018)

A detached accessory structure shall be located to the rear of the principal dwelling structure but no closer to any side or rear lot line than the following:

1. Twenty-five (25) feet in the AG and ten (10) feet R-1 Districts.
2. Ten (10) feet in the R-2 and R-3 and PURD Districts and for manufactured home subdivisions in the MHR District. Six (6) feet in the OR District.

B. Permitted Area and Height

The total area of all accessory uses or structures shall not exceed two percent (2%) of the area of the lot on which the structure or use is located except in the R-1 District in which the total area of all accessory uses or structures shall not exceed four (4%) of the area of the lot on which the structure or use is located. These area requirements shall not apply to lakes, ponds, swimming pools and tennis courts. An accessory structure shall not exceed twenty-five (25) feet in height. The provisions of this subsection 29.03 B shall not apply to property in the AG and PB Districts.

In the OR District, no more than two (2) accessory structures shall be permitted on a residential lot, not more than one of which may be a storage building. Total square footage on accessory structures shall not exceed 1200 sq. ft. and no structure shall exceed eighteen (18) feet in height.

Section 29.04 Private Swimming Pools

A "private swimming pool" as regulated herein, means any pool or open tank (not including lakes or ponds) not located within a completely enclosed building and containing water to depth, at any point greater than two (2) feet. No such swimming pool, exclusive of portable swimming pools with an area of less than 300 square feet, shall be allowed in any residential district unless the following conditions and requirements are complied with:

- A. The pool is intended to be used solely for the occupants of the principal use of the property on which it is located.
- B. All lights used for the illumination of the swimming pool and adjacent areas shall be designed, located and installed so as to confine the direct beams thereof to the lot or parcel on which the pool is located.
- C. The swimming pool shall meet the setback requirements for accessory structures.

A zoning certificate shall be required for the construction or installation of any private swimming pool. The owner of the property, or his agent, shall certify that the

pool will be constructed, installed and maintained in conformance with the above requirements.

Section 29.05 Fences and/or Hedges in Particular Districts

"Fence" or "wall" means any structure composed of wood, metal, stone, brick or other material (including hedges or other plants) erected in such a manner and location so as to enclose, partially enclose or divide any premises or part of premises for the purpose of confinement, screening, partitioning, or decoration. Trellises or other structures for the purpose of supporting vines, flowers or other vegetation, when erected in such a position so as to enclose, partially enclose or divide any premises or any part of premises shall also be considered a fence. Notwithstanding the foregoing, a "fence" or "wall" does not include landscaping trees, planted along an adjacent property line, provided that the planting shall not obscure the vision of motorists.

No fence, hedge, or wall shall be erected on any lot in such a manner so as to obscure the vision of motorists approaching a street intersection. All fences and walls shall comply with section 29.05. However, only those fences or walls located within 20 feet of a property line shall obtain a zoning certificate prior to the installation or construction of such fence or wall. Applications for a zoning certificate for a fence or wall shall include a detailed drawing or photograph of the proposed fence and a site plan indicating its location.

The fence or wall shall not encroach on the right-of-way of any adjacent street, road or highway. Fences or walls shall be structurally sound, safe, and be properly maintained in good condition.

Fences or walls shall be designed, constructed, and finished so the supporting members thereof shall face the property owner of the fence. Ground areas between the fence and the property line and between fences shall be kept properly maintained at all times.

- A. The following additional provisions shall apply only to fences and walls in the O-R, R-1, R-2, R-3, PCRD, PURD and MHR Districts:
 - i. Fences located in a front or corner lot front yard shall not exceed four (4) feet in height. The fence shall be located at least forty feet (40') from the centerline of any such adjacent right-of-way;
 - ii. The height of a fence located in a side or rear yard is restricted to 7 feet;
 - iii. No person shall erect or maintain any fence or wall charged with electrical current, nor shall any person erect or maintain any fence or wall having wire or metal prongs or spikes, or other cutting points or edges. This provision shall not prohibit ornamental wrought iron and similar decorative type fencing. This shall also not prohibit underground invisible fences installed for the purpose of confining pets to property.

- B. The following additional provisions shall apply only to fences and walls in the GC, NC, SO, and SU Districts:
 - i. Fences located in a front or corner lot front yard shall not exceed four (4) feet in height. The fence shall be located at least forty feet (40') from the centerline of any such adjacent right-of-way and adequate sight distance is maintained; and
 - ii. The height of fences located in a side or rear yard is restricted to 12 feet.

Section 29.06 Lakes and Ponds

Lakes and ponds shall be considered as an accessory use where so indicated in the district regulations. Such lakes and/or ponds shall meet the following requirements:

- A. A zoning certificate shall be required prior to the commencement of any construction. The applicant shall provide a site plan for the property, indicating the location of the lake and/or pond, as well as the location of inlets, outlets, subsurface drainage, septic lines, and/or primary or secondary leach field site(s).
- B. The lake and/or pond shall be located not less than sixty (60) feet from any property line, leach field, and/or subsurface tile drainage passing through the property.
- C. The applicant shall demonstrate that the lake or pond meets the standards and specifications of the Natural Resources Conservation Service (NCRS) of the U.S. Department of Agriculture (USDA). These standards and specifications are available through the Pickaway County Soil and Water Conservation District (PSWCD).
- D. All ponds shall be properly maintained and shall function as originally designed and shall be free from objectionable conditions (i.e. odors, improper drainage, etc.) so as not to be a public nuisance. No pond shall be constructed within the boundaries of the 100-year flood plain of any waterway.
- E. No lake or pond shall be located within the required front yard setback for principal buildings in the zoning district which the land and/or pond is proposed to be constructed.
- F. The application for a zoning certificate shall be accompanied by a letter or other documentation showing approval of the proposed lake and/or pond by the Pickaway County Soil and Water Conservation District.
- G. Retention and detention ponds delineated on a plat and constructed as part of a subdivision and regulated by applicable subdivision regulations shall be exempt from the requirements of this Section.

Section 29.07 Telecommunications Towers

Telecommunications towers, as defined herein, may be allowed as a conditional use in the (R-1) Rural Residential District. The process to be used in processing an application for such a tower shall be as specified in Section 519.211 of the Ohio Revised Code and Article IX of this Resolution. Telecommunications towers shall be subject to the following conditions:

- A. No telecommunications tower shall be permitted to be located in any platted subdivision approved under Sections 711.05, 711.09 or 711.10 of the Ohio Revised Code, or in any area consisting of fifteen (15) or more lots approved under Section 711.131 of the Ohio Revised Code that are contiguous to one another or some of which are contiguous to one another and adjacent to one side of a dedicated public road, and the balance of which are contiguous to one another and adjacent to the opposite side of the same dedicated public road, when at least thirty-five percent (35%) of the lots within such subdivision or area are developed with at least one (1) dwelling unit.
- B. Maximum height of the tower shall not exceed 150 feet.
- C. The tower shall be located not less than 350 feet from any existing residential dwelling or any public roadway.
- D. A tower shall be located no closer to any lot line than the distance equal to the height of the proposed tower. Any stabilization structures or guide wires shall be located no closer to any lot line than 50 feet.
- E. Security fencing shall be provided to prevent uncontrolled access to the tower site. The fencing shall be maintained in good condition. The fence shall contain no advertising, but may contain one small identification sign not to exceed one square foot in size. The applicant is responsible for ensuring that the area on which the tower is to be located is kept free of weeds and trash. The storage of vehicles is prohibited and any equipment must be contained inside the fenced area.
- F. The minimum lot size for the site of the tower shall be two (2) acres. The lot on which the tower is to be located shall meet the minimum lot frontage requirements of the district in which it is located.
- G. The tower shall not contain, or be illuminated by, artificial lights, beacons or strobes, unless otherwise required by the Federal Aviation Administrations (FAA) or the Federal Communications Commission (FCC). Any illumination required or believed to be required by applicable governmental authority shall be fully disclosed on the site plan. All surfaces shall be maintained in good condition, absent of flaking or peeling paint, and rust. Unless

otherwise approved by the Board of Zoning Appeals, the tower shall be of a non-corrosive monopole design.

- H. No advertising is permitted anywhere on the telecommunications tower with the exception of one identification sign not to exceed one square foot in size.
- I. The tower shall be fully automated and shall be visited only for periodic and necessary maintenance.
- J. Where the tower is located on a property which is not owned by the tower operator, the applicant shall present documentation that the owner of the property has approved the application.
- K. The applicant or tower provider shall demonstrate that the telecommunication tower must be located where it is proposed in order to service the applicant's service area that other sites have been considered, and that location at the proposed site is technically necessary.
- L. The applicant shall provide a signed statement indicating that he/she agrees to allow for the potential co-location of other similar facilities on the tower, the removal of the tower within 180 days after the site's use is discontinued, and proof of notice has been provided as required in Section 519.211 of the Ohio Revised Code, as may be subsequently amended.
- M. If a public telecommunications service provider desires to co-locate its antenna on an existing tower which will not substantially increase the tower's height, the location of such facility shall be addressed as a permitted use.
- N. For purposes of this Resolution, a telecommunications tower is defined as any free-standing structure, or any structure to be attached to a building or other structure, that meets all of the following criteria:
 - 1. The free-standing or attached structure is proposed to be constructed on or after the effective date of the Ohio Revised Code amendment to Section 519.211 (i.e. 10/31/96).
 - 2. The free-standing or attached structure is proposed to be owned or principally used by a public utility (or a functionally equivalent provider) engaged in the provision of telecommunications services.
 - 3. The free-standing or attached structure is proposed to be located in an unincorporated area of the Township, in an area zoned for residential use. Areas zoned for residential use shall include all land located within the following Zoning Districts: (R-1) Rural Residential District; (R-2) Suburban Residential District; (R-3) Urban Density Residential District; (MH-R) Manufactured Home Residential District; Planned Conservation Residential Zoning District (PCRD); and (PURD) Planned Unit Residential Development District.

4. The free-standing structure is proposed to top at a height that is greater than 48 feet. In the case of an attached structure, such structure is proposed to top at a height that is eight (8) feet greater than the height of the building or other structure to which it is to be attached.
 5. The free-standing or attached structure is proposed to have attached to it radio frequency transmission or reception equipment.
- O. Telecommunications towers shall be prohibited in the O-R, R-2, R-3, MH-R, PCRD and PURD Zoning Districts.

ARTICLE XXX

OFF-STREET PARKING REQUIREMENTS

Section 30.01 Purpose

The purpose of these requirements is to encourage the orderly development of parking and loading areas within Scioto Township and to promote the safety of residents and visitors by insuring the efficient handling of vehicular traffic. These off-street parking and loading standards apply throughout the Township. If a conflict exists between these standards and more specific standards prescribed in any individual zoning district, the specific provisions of the zoning district in question shall prevail. The standards set forth herein are to be considered minimum standards to be augmented by standards set forth elsewhere in this Resolution or prescribed or agreed to by the land owner in any rezoning or variance.

Section 30.02 Provision for Parking Required

In all zoning districts, at the time any building, structure or use is changed, established, erected, developed, or is enlarged or increased in capacity, there shall be provided off-street parking spaces in accordance with the provisions of this Article.

Section 30.03 General Requirements

A. Surfacing

All off-street parking areas and adjacent aisles and driveways within the SO, NC, PB, GC, PI, PURD and/or SU Districts shall be paved with concrete, asphaltic concrete, premixed asphalt pavement, blacktop or brick so as to provide a durable and dustless surface. All off-street parking areas and driveways for single-family dwellings in the Agricultural, MH-R, PCRD and Residential zoning districts shall be hard surfaced, which surface may consist of an aggregate base, and shall be maintained in such manner that no dust will be produced by continuous use.

B. Drainage

All parking spaces, together with driveways, aisles, and other circulation areas shall be graded and drained so as to dispose of surface water which might accumulate within or upon such area, and shall be designed to prevent the excess drainage of surface water onto adjacent properties, walkways, or onto public streets. Adequate arrangements shall be made to insure acceptable diversion to an adequate storm water drainage system.

C. Lighting

Any lighting used to illuminate any off-street parking area shall be so arranged as to reflect light away from any adjoining premises in any zoning district where residences are a permitted use. In addition, such lighting shall be so arranged as

not to interfere with traffic on any adjoining street or to be confused with any traffic control lighting.

D. Location of Parking Spaces

A twenty (20) foot clear zone shall be maintained between the edge of the road pavement and any parking space, except a ten (10) foot clear zone in the O-R District. Parking areas shall be so designed and arranged so as not to allow the protruding of any vehicle (or portion thereof) over the clear zone. Required off-street parking facilities shall be located on the same lot as the structure or use served, except that a parking facility for nonresidential uses providing the sum of parking space required of several uses may be provided contiguous and in common to the several structures and uses served. All parking spaces shall be marked with paint lines, curb stones, or in a similar manner and maintained in clearly visible condition. All parking areas shall be maintained in good condition without holes and free of all dust, trash, or other debris.

Section 30.04 Parking Limitations in Residential Districts

A. Recreational Vehicles

The parking or storage of recreational vehicles (other than inoperable vehicles) in the O-R, R-1, R-2, R-3, MH-R, PCRD and PURD zoning districts shall be subject to the following requirements:

1. No recreational vehicle shall be parked or stored on a lot which is not improved with an occupied single-family detached dwelling.
2. If the lot is one (1) acre or less, exclusive of public right-of-ways, not more than one (1) recreational vehicle may be parked or stored outside of any enclosed structure. If the lot area is more than one (1) acre, exclusive of public right-of-ways, not more than two (2) recreational vehicles may be parked or stored outside of an enclosed structure.
3. When parked or stored outside of an enclosed structure, the recreational vehicle shall be placed in accordance with the location and setback requirements for accessory structures under Section 29.03. Also, the recreational vehicle shall be parked or stored on a hard surface consisting either of aggregate or pavement which shall be maintained in such a manner that no dust is produced.
4. A recreational vehicle shall not be occupied as a dwelling unit or used for living, sleeping and/or housekeeping purposes for any period of time exceeding fourteen (14) calendar days in any consecutive six (6) calendar months.
5. The wheels or any similar transporting devices of any recreational vehicle shall not be removed except for repairs which are promptly commenced and completed within twenty-four (24) hours nor shall any recreational vehicle be permanently attached to the ground.
6. The term "recreational vehicle" shall mean any vehicle manufactured or modified to contain living quarters for travel, recreation, or vacation purposes including, but not necessarily limited to, a camper, travel trailer, truck camper, and motor home. The term "recreational vehicle" shall also include boats, boat trailers, personal water craft, and trailers

therefore, golf carts and trailers therefore, all terrain vehicles and trailers therefore, off road utility vehicles and trailers therefore, motorcycles not licensed for use on public highways and trailers therefore, car hauling trailers, unlicensed racecars, go carts, snowmobiles, and trailers therefore, horse trailers and other similar recreational trailers and equipment.

For the purpose of this definition, a watercraft or other recreational vehicle stored on a trailer designed and used for that watercraft or other recreational vehicle shall be considered a single recreational vehicle. A recreational vehicle shall not include an “inoperable vehicle”.

B. Inoperable Vehicles

The parking or storage of inoperable vehicles in the O-R, R-1, R-2, R-3, MH-3, PCRD and PURD zoning districts shall be subject to the following requirements:

1. No inoperable vehicle shall be parked or stored on a lot which is not improved with an occupied single-family detached dwelling.
2. If the lot is one (1) acre or less, exclusive of public right-of-ways, not more than one (1) inoperable vehicle may be parked or stored outside of any enclosed structure. If the lot area is more than one (1) acre, exclusive of public right-of-ways, not more than two (2) inoperable vehicles may be parked or stored outside of an enclosed structure.
3. When parked or stored outside of an enclosed structure, the inoperable vehicle shall be placed in accordance with the location and setback requirements for accessory structures under section 29.03. Also, the inoperable vehicle shall be parked or stored on a hard surface consisting either of aggregate or pavement which shall be maintained in such a manner that no dust is produced. In addition, the inoperable vehicle shall be completely enclosed within a fence at least six (6) feet in height so as not to be visible from any adjacent lot or street. The fence shall consist of a barrier of material, such as wood, stone, vinyl, masonry or a combination of materials which are commonly and utilized for attractively and effectively enclosing and screening areas of land.

Manufactured material that is not originally manufactured for purposes of fencing and/or screening shall not be utilized as fence material.

4. An automobile or other motor vehicle shall be deemed to be an “inoperable vehicle” if it meets any one of the following criteria:
 - a. The vehicle is without a valid, current registration decal and/or license plate or it does not meet Ohio Revised Code requirements for operation on a public street.
 - b. The vehicle is apparently inoperable due to missing or inoperable mechanical or electrical parts.
 - c. The vehicle is without fully inflated tires and/or has any type of support under it.

- d. The vehicle has a missing or shattered window or windshield.
- e. The vehicle has an extensively damaged or missing door, hood, trunk lid, fender, motor, transmission, wheel, tire, or other similar major part.

C. Construction Vehicles and Equipment

The outdoor storage or parking of backhoes, bulldozers, well rigs and other similar construction vehicles or equipment, other than vehicles or equipment temporarily used for on-going construction upon the site, shall be prohibited outside of the PI District.

Section 30.05 Required Parking and Loading Plan

A parking and loading plan shall not be required for single-family or two-family residential uses. All other land uses shall submit a parking and loading plan to the Zoning Inspector as a part of the application for a Zoning Permit. The parking and loading plans shall show boundaries of the property, parking spaces, loading areas, circulation patterns, drainage plans, construction plans for any boundary walls or fences, a screening plan, and the location of adjacent houses or buildings. Required off street parking and loading facilities shall be located on the same lot as the structure or use served, except that a parking facility providing the sum of parking space required of several nonresidential uses may be provided contiguous and in common to the structures and uses served.

Section 30.06 Required Dimensions

- A. All parking spaces shall be not less than nine (9) feet wide and twenty (20) feet long. Such spaces shall be measured as a rectangle and shall be served by aisle ways of sufficient width to permit easy and smooth access to all parking spaces.
- B. All driveways and aisles serving parking lots for five (5) or more vehicles shall be served by a driveway not less than twenty (20) feet in width but adequate in width to permit easy access to parking spaces. No driveway shall be located so that it enters a public road within one hundred (100) feet of the intersection of any two (2) public roads unless there are two (2) driveways serving the lot, one of which is more than one hundred (100) feet and the other not less than forty (40) feet from said intersection. All driveways shall be located and the adjoining lots graded so that vehicular traffic entering a public road has an unobstructed sight distance of at least three hundred (300) feet.

Section 30.07 Required Numbers of Off-Street Parking Spaces

Parking spaces shall be provided according to the following Schedule which is hereby made a part of this Resolution.

USE	NUMBER OF PARKING SPACES
A. RESIDENTIAL	
1. Single or multiple-family residences.	Two (2) per dwelling unit.
2. Institutional housing.	One (1) per three (3) occupants plus one (1) for each main work shift.
B. RECREATIONAL	
1. Softball, baseball, football, soccer or similar organized sport playfield.	20 for each playfield, plus one (1) for each six (6) seats in stands.
2. Tennis, handball, or racquetball courts.	Three (3) for each court.
3. Bowling alleys.	Five (5) per lane plus necessary spaces as required for affiliated uses, such as restaurants.
4. Theatres, stadium or sports arenas, auditoriums or other assembly halls other than schools.	One (1) for each four (4) seats.
C. INSTITUTIONAL	
1. Churches and other places of public worship.	One (1) for each five (5) seats in main auditorium.
2. Public or private school.	Three (3) for each classroom or one (1) for each five (5) seats in main auditorium whichever is greater.
3. Nursery School/Day Care (other than Type B).	One (1) for each fifteen students of proposed capacity.
4. Libraries, museums, community centers.	One (1) for each 400 square feet of gross floor area.
5. Civic, social, fraternal organizations.	One (1) for each three (3) persons allowed under maximum occupancy of main meeting room.
6. Hospitals, nursing facilities.	One (1) for each four (4) beds plus one (1) per employee on main shift.
7. Other public or institutional uses.	One (1) for each 400 square feet of gross floor area.
D. COMMERCIAL	
1. Food, department or general merchandise, hardware, drugs, and other retail sales.	One (1) for each 200 square feet of gross floor area.
2. Eating and drinking establishments without drive-through facilities	One (1) for each 100 square feet of gross floor area.
3. Restaurants with drive-through facilities.	One (1) for each 75 square feet of gross floor area, plus additional spaces in the drive-through lanes equal to 25 percent (25%) of the required number of parking spaces.
4. Personal services, including banks, savings and loans, repair services without drive-through facilities.	One (1) for each 200 square feet of gross floor area.
5. Banks, savings and loans and similar uses with drive-through facilities.	One (1) for each 200 square feet of gross floor area, plus additional spaces in all drive-through lanes equal to 80 percent (80%) of the required number of parking spaces.
6. Barber and beauty shops.	Two (2) for each work station.
7. Gasoline and service stations, automobile service.	Two (2) for each service bay plus one (1) for each two (2) gasoline dispensing units, plus one (1) for each employee during main shift.

USE	NUMBER OF PARKING SPACES
8. Self-service laundries.	One (1) for each three (3) washers.
9. Hotels, bed and breakfast establishments.	One (1) for each sleeping room or suite, plus one (1) for each employee during main shift.
10. Funeral Home.	One (1) for each 50 square feet of gross floor area.
11. Medical or dental offices; animal hospitals/clinics.	Five (5) for each doctor or dentist.
12. Professional, administrative and business offices and all other types of business or commercial uses.	One (1) for each 400 square feet of gross floor area.
E. INDUSTRIAL	
1. Marketing, compounding, processing, assembling, packaging or treating of goods; warehousing, distribution and service industries.	Two (2) for each three (3) employees during work shift having greatest number of employees, plus one (1) for each vehicle maintained on the premises.

ARTICLE XXXI

SIGNS

Section 31.01 Purpose

The purpose of these regulations is to encourage the proper development of signs and signage systems within Scioto Township. It is further the intent of these regulations to prevent signs from becoming a distraction to the safe flow of traffic, to prevent signs from becoming a nuisance to adjacent properties or uses, to protect and encourage a healthful economic business environment in the community and, thereby, protect the public health, safety, and welfare of the community.

Section 31.02 Definitions

As used in this Article, the following words or phrases shall have the meanings herein:

- A. "Sign" means any device for visual communication which is designed or used to convey a message, advertise, inform or otherwise direct attention to a person, institution, organization, activity, business, place, object or product. Signs erected by the local, State or federal government for the purposes of discharging in any normal governmental function, such as traffic control or safety, are likewise excluded from these regulations of this Article.
- B. "Billboard" or "Off-Premise sign" means any sign identifying, promoting or advertising a product or service not located on the same property as the sign.
- C. "Freestanding sign" means a sign erected on a pole, poles, pillars, or posts embedded in the ground and which is wholly independent of any building for support.
- D. "Permanent sign" means a sign intended to be erected, displayed or used, or in fact which is used for time period in excess of six (6) months.
- E. "Portable sign" means a sign designed or constructed in such a manner that it can be moved or relocated without involving any structural or support changes and shall include signs that are constructed on a chassis or trailer.
- F. "Temporary sign" means a sign intended to be displayed for a time period of less than six (6) months.
- G. "On premise sign" means a sign related to a business or profession conducted, or a commodity or service sold or offered, upon the premises where such sign is located.
- H. "Wall sign" means a sign attached to a building face, with the exposed face in a plane parallel to the plane of the wall. Wall signs include painted murals, messages, graphics and other designs

along with any letters or numerals mounted on buildings and any extensions thereon.

- I. “Window sign” means a sign, graphic, poster, symbol or other identification or information about the use or premises which is physically affixed to or painted on the glass or other structural component of the window or a sign, graphic, poster, symbols, or other identification or information about the use or premises erected on the inside of the building within two feet of the window and intended to be viewed through the window from the exterior of the premises.
- J. “Informational Window sign” means a window sign with a total sign area of two square feet or less and bearing only information about entry and exit, business hours, authorized service representative information and/or discount and credit systems accepted in that establishment.
- K. “Menu Board sign” means a permanent sign displaying the bill of fare for a restaurant, drive-in or drive-through restaurant or instructions or services for other drive-through establishments.
- L. “Banner or pennant” means a non-rigid cloth, plastic or canvas sign typically related to a special event or promotion. National or state flags and flags of political subdivisions shall not be considered banners. The official flag of any institution or business shall be considered a banner.

Section 31.03 Sign Permits

A. Permit Required

No permanent or temporary sign, except as exempted in Section 31.04 of this Resolution, shall hereafter be erected, constructed or maintained within Scioto Township unless a permit for the same has been issued by the Zoning Inspector. A sign for which a permit has been issued shall not be modified, changed or amended so as to differ from that approved in the permit unless a new or amended permit is issued.

B. Contents of Application

Application for a permit to construct or erect a sign shall be made by the owner of the property upon which the sign is proposed, or his/her agent. The fee shall be established by separate resolution. The application for a sign permit shall be made on forms as provided by the Zoning Inspector, and shall include the following information:

1. Name, address, and telephone number of the applicant.
2. Drawing or drawings showing, at a minimum:
 - a. The design and layout of the proposed sign, including the total area of the sign and the size, height, character, materials and color of letters, lines, and symbols.
 - b. The method of illumination, if proposed.

- c. The exact location of the sign in relation to the building and property.
3. Such other information as may be required in order to determine compliance with this Resolution.

Section 31.04 Signs Which Do Not Require a Permit

The following signs may be erected without a permit, subject to the regulations set forth herein.

- A. Address and name of occupant of premises for a residential structure, to be limited in size to two (2) square feet.
- B. Signs which are in the nature of cornerstones, commemorative tables and historical plaques, provided that such signs are less than nine (9) square feet in size and not illuminated.
- C. Signs clearly in the nature of decorations customarily associated with national, local or religious holiday. Such signs may be of any illumination or animation provided that safety and visibility hazards are not clearly created.
- D. Political signs or posters concerning candidates for elective office, public issues and similar matters to be decided by public election, to be displayed beginning no more than forty-five (45) days prior to election and to be removed no later than fifteen (15) days after such election. Such signs shall not be illuminated, nor be located within a public right-of-way.
- E. On-premise signs that indicate the sale, rental or lease of a particular structure or land area, to be limited to one sign allowed per road front. Such signs shall not be located in a public right-of-way. These signs shall not be illuminated and shall not exceed six (6) square feet of sign area per side with not more than two (2) sides.
- F. Temporary window signs which promote special business sales, promotion or occasions.
- G. Signs which are less than four (4) square feet in sign area and mounted or attached flat or parallel onto a building face of an administrative, business or professional office building, which denote the name and address of an occupant in a building where more than one tenant is located.
- H. Signs which advertise the sale of personal property, such as a garage, yard, porch or moving sales, provided such signs are displayed for a time period not greater than three (3) consecutive days are removed within two (2) days after the sale and are not located within a public right-of-way. These signs shall not exceed six (6) square feet of sign area per side.
- I. On-premise farm signs denoting the name and address of the occupant, produce or products for sale, and/or membership in

organizations. Such signs shall be located outside the road right-of-way. Advertising sale signs may not exceed thirty-two (32) square feet of sign area and all other signs shall be limited to six (6) square feet of sign area per side.

- J. On-premise temporary construction signs which display the identification of the construction project, including identification of the contractors, architects and other construction principals provided that such construction sign is removed upon the completion of construction or the commencement of occupancy, whichever event occurs first. The maximum sign area shall not exceed twenty (20) square feet. There shall only be one (1) such sign permitted per road front.
- K. Signs promoting community events and programs which are sponsored by nonprofit, public, educational, religious and charitable organizations. Such signs shall not be displayed for more than twenty-one (21) consecutive days and such signs shall be removed not later than three (3) days after the scheduled activity.
- L. The flag, pennants or insignia of any nation, state, city or other political unit.
- M. Informational window signs provided such sign area does not exceed ten (10) square feet per business establishment.
- N. On-premise traffic directional signs indicating points of entry or exit to a facility or off-street parking area, provided such signs are limited to four (4) square feet in sign area and two (2) feet in height as measured from the natural grade of the site location. No more than two (2) such signs are allowed per vehicular access point and no advertising material shall be permitted on these signs. Such signs shall be located outside the right-of-way.
- O. Banners, temporary wall signs and pennants less than 16 square feet are permitted as temporary on-premise signs provided that they are attached at each corner, point and/or end so as to prevent movement. Banners may be attached to ground signs within the frame provided that they are attached at each corner, point and/or end so as to prevent movement. Only one banner is permitted per establishment. No business shall display such signs for more than ninety (90) days per calendar year or for more than thirty (30) continuous days. The date each sign is first displayed and the time period for which the sign will be displayed shall be legibly marked on the sign. The area of each banner shall not count toward the minimum sign area specified herein.

Section 31.05 Sign Standards

Temporary and/or permanent signs designated below which are erected after the date of this Resolution shall comply with the following standards:

A. Off-Premise Signs

Billboards are permitted in the SO, NC, GC, PI, and PB Districts, and lands used for agricultural purposes, subject to compliance with the development standards of the zoning district in which the billboard location is sought and the following criteria:

1. Billboards shall be located in accordance with the following provisions.
 - a. Billboards shall be located behind the principal building setback line for the district in which it is located and shall not be erected within any required yard areas.
 - b. Billboards shall be located not less than two hundred (200) feet from any adjacent residential dwelling unit.
2. Billboards shall be located at least seven hundred fifty (750) feet in any direction from other billboards. This required separation between billboards shall be determined as follows:
 - a. Spacing requirements shall be measured along the curb line of the street that the billboard is oriented to and the measurement shall apply to both sides of the street.
 - b. Spacing requirements shall be measured from existing billboards regardless of the political jurisdiction within which any other billboard may be located.
 - c. Measurement of the spacing between billboard locations shall begin at a point nearest to the proposed billboard site location from an existing billboard site location and extending to a point nearest to the existing billboard site location from the proposed billboard site location.
3. No billboard shall exceed three hundred (300) square feet in sign area per side and shall not have more than two (2) sides.
4. All billboards shall be located in compliance with all local, state, and federal regulations controlling the same. Billboards shall be licensed or permitted as may be required by local, state, or federal agencies.
5. The height of a billboard shall not exceed twenty-five (25) feet above the natural grade of the site location.
6. No off-premise signage shall be erected or maintained in trees, or constructed, drawn or painted directly onto rocks or other natural features.

B. Off-Premise Directional Signs

Off-premise directional signs which direct persons to a business located within two (2) miles from such sign, or to a place of assembly (such as places of worship, libraries, schools and similar uses), or for emergency care (such as hospitals, fire departments, police departments and similar uses) are permitted under the following conditions:

1. The sign owner must have the written permission of the property owner for the location of such sign.
2. The sign shall be set back not less than ten (10) feet from the road right-of-way line and shall not obstruct traffic visibility.

3. The sign shall convey only directional information, and shall not exceed four (4) square feet of sign area per side and six (6) feet in height as measured from the natural grade of the sign location.
4. No organization shall have more than two (2) off-premise directional signs within the Township.
5. No more than two (2) off-premise directional signs may be permitted on any single lot.

C. On-Premise Signs

Free-standing, wall-mounted, window or projecting on-premise signs identifying and/or promoting uses or activities on the premises are permitted as part of the principal use in the SO, NC, GC, PI, PB and SU Districts. In the PB, PI and SU Districts, the location of such sign must be in strict compliance with the development plan submitted as part of the approval process. All on-premise signs shall meet the following criteria:

1. No single sign shall have a sign area of more than forty (40) square feet per side and shall not have more than two (2) sides.
2. No single use or property shall maintain a total sign area for all on-premise signs of more than 100 square feet.
3. No on-premise sign shall be erected closer than twenty-five (25) feet to the road right-of-way and shall not be located in any required rear or side yard area.
4. No on premise sign shall exceed twenty-five (25) feet in height, as measured from ground level.
5. There shall be only one (1) free-standing on-premise sign allowed to be erected to serve any one (1) business establishment. Where more than one (1) business establishment is located on a single tract of land, having an entrance or entrances or parking area or areas used in common by the customers of such establishments, only one (1) free-standing on-premise sign is permitted for the entire tract.

D. Permanent Subdivision or Multi-family Development Signs

A subdivision or multi-family development sign is defined as an on-premise ground-mounted sign that graphically identifies a subdivision and/or multi-family development. Not more than two (2) subdivision and multi-family development signs are permitted at each entrance to such a development. Such signs shall meet the following criteria.

1. The total sign area of all signs at an entrance shall not exceed twenty (20) square feet. A subdivision or multi-family development sign shall be mounted on brick, masonry, concrete or other suitable base.
2. The maximum height of a subdivision or multi-family development sign shall not exceed six (6) feet.
3. No part of any such sign shall be closer to any public right-of-way than ten (10) feet and no closer to any other property line than the applicable building setback line. Ground-mounted signs shall not act as an obstruction or visual impairment to vehicular traffic and shall not inhibit or obstruct ingress-egress on the subject parcel and adjacent lots.

E. Menu Board Signs

A drive-through or drive-up menu board sign is permitted as part of the principal use in the SO, NC, GC, PB, PI and SU Districts. In the PB, PI and SU Districts, the location of such sign shall be in compliance with the development plan submitted as part of the approval process. All such signs shall meet the following criteria:

1. The sign shall be located on the property on which the principal use is located.
2. The sign shall be oriented solely for the use of patrons utilizing the drive-through.
3. The sign shall not exceed (32) square feet in total sign area and shall not be located in any required yard area.

F. Subdivision Sale Signs

Signs providing information on the sale of lots within an approved and recorded subdivision may be placed upon the property until such time as ninety (90%) percent of the lots within the subdivision are sold. Subdivision sale signs shall contain only the name of the subdivision, the name of the owner, the name of the developer, and information regarding the price, terms and the location and phone number of the sales office. All such signs shall meet the principal building set back requirements of the applicable district. The maximum sign area shall be twenty (20) square feet per side and shall have not more than two (2) sides. There shall be no more than two (2) such signs for a subdivision. The height of such signs shall not exceed six (6) feet.

G. Bulletin Boards

On-premise bulletin board signs with changeable copy customarily incidental to places of worship, recreational areas, governmental facilities and schools shall be permitted for the uses hereinafter listed, subject to the following criteria:

1. One (1) such sign shall be allowed for the following uses:
 - a. Churches.
 - b. Public parks, playgrounds and community centers.
 - c. Publicly owned and operated buildings and facilities.
 - d. Schools and colleges for academic instruction.
2. The sign shall be located on the property on which the principal use is located and there shall be no more than one (1) such sign on the property.
3. The sign shall be setback from the street right-of-way a minimum of fifty percent (50%) of the front principal building setback for the applicable zoning district. The sign shall not be located in any required side or rear yard.
4. The sign shall not exceed six (6) feet in height above the grade of the property.
5. The sign shall not exceed thirty-two (32) square feet in sign area per side and not have more than two (2) sides.

Section 31.06 General Requirements for all Signs

All signs shall comply with the following regulations:

- A. When a sign is proposed to be illuminated, such illumination shall be from a concealed or indirect light source and shall not flash, blink, fluctuate in intensity, travel, and move or in any manner fail to provide constant illumination, and shall not create a hazard or visibility problem or interfere with or impair vehicular traffic. The level of illumination emitted from a sign shall not be of an intensity to constitute a demonstrable safety hazard to vehicular movement on any street. Illuminated signs shall be constructed and maintained so that the source of illumination is shielded or otherwise prevented from beaming directly onto adjacent properties or streets.
- B. Moving signs and the animation of signs are prohibited.
- C. All signs and parts thereof, including any electrical wiring, shall be erected, constructed, and maintained so as not to constitute a safety hazard and shall be kept in a proper state of maintenance and repair.
- D. No sign or part of any sign shall be placed in, over, or extend onto any public right-of-way, nor shall any part of a sign be placed over, or extend above the roof of any structure.
- E. No sign shall be located so as to hinder clear sight within fifty (50) feet in both directions at the intersection of any roadway.
- F. All wiring, fittings, and materials used in the construction, connection, and operation of electrically illuminated signs shall be in accordance with the provisions of the local electric code in effect.
- G. Portable signs shall not be placed on any building, land, lot, parcel, premises, or in or on any road right-of-way.
- H. No sign or part thereof shall contain or consist of ribbons, streamers, spinners, or other similar moving devices. Such devices, as well as strings of lights, shall not be used for the purpose of advertising or attracting attention.
- I. The bottom of all freestanding signs shall maintain a minimum clearance of eight (8) feet above any pedestrian area and fourteen (14) feet above any parking or loading area.

Section 31.07 Measurement of Sign

For the purposes of this Resolution, the measurement of sign area shall comply with the following standards:

- A. Sign area shall include the face of all the display area of the sign not including bracing, framing and structural supports of the sign, unless such support members are made part of the message or face of the design. Where a sign has two or more display faces, the area of all faces of the sign shall be included in determining the total area of the sign.
- B. The area of the letters, numbers or emblems mounted on a building wall or wall extension shall be computed by enclosing such sign with the smallest single continuous perimeter consisting of rectangular or series of rectangles around letters, number or emblems and determining the area.

Section 31.08 Nonconforming Signs

A. Abandonment

The continuance of an existing sign which does not meet the regulations and requirements of this Article shall be deemed a nonconforming sign which shall terminate by abandonment when any of the following conditions exist:

- 1. When the sign is associated with an abandoned use.
- 2. When the sign remains after the termination of a business. A business has ceased operations if it is closed to the public for at least two (2) years.
- 3. When the sign is not maintained or does not conform to the following:
 - a. All signs, together with all supports, braces, guys and anchors shall be kept in a proper state of repair.
 - b. Every sign and the immediately surrounding premises shall be maintained by the owner, or his agent, in a clean sanitary and inoffensive condition, free from all obnoxious substances, rubbish and weeds.

Upon finding that the sign is abandoned, the right to maintain and use such sign shall terminate immediately.

B. Relocation or Replacement

A nonconforming sign shall not be structurally relocated or replaced unless it is brought into compliance with the provisions of this Resolution.

C. Maintenance

A nonconforming sign shall be maintained or repaired in accordance with the following provisions:

1. The size and structural shape of the sign shall not be changed or altered. The copy may be changed provided that the copy area shall not be enlarged.
2. In case damage occurs to the sign to the extent of sixty percent (60%) or more of either the structure or the replacement value of the sign, the sign shall be brought into compliance or removed within sixty (60) days following the occurrence. Where damage to the sign is less than sixty percent (60%) of the structure or its replacement value, the sign shall be repaired within sixty (60) days of the occurrence.

ARTICLE XXXII

ADULT ENTERTAINMENT BUSINESSES

Section 32.01 Purpose

The purpose of this Article is to promote the public health, safety and welfare through the regulation of adult entertainment businesses. It is the intent of this Article to regulate businesses, as defined herein, in such a manner as to prevent the erosion of the character of the surrounding neighborhoods and to prohibit the establishment of such businesses within close proximity to schools, churches, residential areas, parks and playgrounds within the Township.

Section 32.02 Definitions

- A. “Adult Entertainment Facility” means any establishment which is involved in one or more of the following listed categories.
 - 1. “Adult Book Store” means an establishment which utilizes fifteen percent (15%) or more of its retail selling area for the purpose of retail sale or rental, or for the purpose of display by coin or slug-operated, or motion picture machines, projectors, or other image-producing devices, or both, books, magazines, other periodicals, films, tapes and cassettes which are distinguished by their emphasis on “specified sexual activities” or “specified anatomical areas” as defined below.
 - 2. “Adult Motion Picture” means a facility for the display of motion pictures which is regularly used or utilizes fifteen percent (15%) or more its total viewing time for presenting material distinguished or characterized by an emphasis to “specified sexual activities” or “specified anatomical areas,” for observation by patrons therein.
 - 3. “Adult Entertainment Business” means any establishment involved in the sale or services of products characterized by the exposure or presentation of “specified anatomical areas” or physical contact of live male or females, and which is characterized by salacious conduct appealing to prurient interest for the observation or participation in by patrons.

Services or products included within the scope of adult entertainment business are photography, dancing, reading, massage, and similar functions which utilize activities as specified above.

- B. “Specified Sexual Activities” means any of the following:
 1. Human genitals in a state of sexual stimulation or arousal.
 2. Acts, real or simulated, or human masturbation, sexual intercourse, sodomy, cunnilingus, fellatio, or sadomasochistic sexual abuse.
 3. Fondling or other erotic touching of human genitals, pubic regions, buttocks, or female breasts.

- C. “Specified Anatomical Areas” mean any of the following:
 1. Less than completely covered human genitals, pubic region, buttocks, and female breasts below a point immediately above the top of the areola.
 2. Human male genitals in a discernible turgid state.

- D. “Fine Art Gallery” means any display of art work which is individually crafted and signed by the artist or which is limited in addition to 1,000 or less.

- E. “Sexually explicit nudity” means the sexually oriented and explicit showing of nudity, including, but not limited to, close-up views, poses, or depiction in such position or manner which present or expose such nudity to prominent, focal, or obvious viewing attention.

- F. “Visibly displayed” means the material is visible on any sign, viewing screen, marquee, newsstand, display rack, window, show case, display case, or other similar display area that is visible from any part of the general public or otherwise, or that is visible from any part of the premises where a juvenile is or may be allowed, permitted, or invited, as part of the general public or otherwise, or that is visible from a public street, sidewalk, park, alley, residence, playground, school, or other place to which juveniles, as part of the general public or otherwise, has unrestrained and reasonable anticipated access and presence.

Section 32.03 Exceptions

Nothing in this Article shall be construed to pertain to:

- A. The purchase, distribution, exhibition and/or loan of any work of art, book, magazine or other printed material or manuscript by an accredited museum, library, fine art gallery, school or museum of higher learning.

- B. The exhibition and/or performance of any play, drama tableau, or motion picture by any theater, museum, library, fine art gallery, school, or institution of higher learning either supported by public appropriation or which is an accredited institution supported by private funds.

Section 32.04 Location

Adult Entertainment Facilities shall be considered a conditional use in the GC District, and shall be subject to the following conditions:

- A. No adult entertainment facility shall be established within 1,500 feet of any residence or district where residences are a permitted use.
- B. No adult entertainment facility shall be established within a radius of 1,500 feet of any school, library, or teaching facility, whether public or private, when such school, library, or teaching facility is attended by persons less than 18 years of age.
- C. No adult entertainment facility shall be established within a radius of 1,500 feet of any park or recreational facility attended by persons less than 18 years of age.
- D. No adult entertainment facility shall be established within a radius of 1,500 feet of any church, synagogue, or permanently established place of religious services attended by persons less than 18 years of age.
- E. No adult entertainment facility shall be established within a radius of 1,500 feet of any other adult entertainment facility.
- F. No advertisements, displays or other promotional materials displaying specified sexual activities or specified anatomical areas shall be shown or exhibited so as to be visible to the public from pedestrian sidewalks or walkways, or from other public or semi-public areas.
- G. All building openings, entries, windows, etc. for adult entertainment uses shall be located, covered, or serviced in such a manner as to prevent a view into the interior from any public or semi-public area, sidewalk or street.
- H. No screens, loudspeakers or sound equipment shall be used for adult motion picture theaters (enclosed or drive-in) that can be seen or discerned from public or semi-public area.

ARTICLE XXXIII

TEMPORARY USES

Section 33.01 Purpose

Because of the special characteristics and needs of temporary uses, special standards to properly locate and control the activities of temporary uses are necessary in order to secure the health, safety and general welfare of the community. The following uses are deemed to be temporary uses and are subject to the following development standards in addition to the development standards of the district in which the use is located.

Section 33.02 Garage Sales

Garage sales and other temporary sales in association with an existing residential dwelling unit shall be permitted in any district in which dwellings are permitted, provided the sales are conducted during daytime hours only and all signs are removed immediately upon cessation of the sale. Such sales activities on any single premises shall not be conducted for a total of more than ten (10) days in any calendar year. No Zoning Certificate shall be required for garage sales meeting these requirements.

Section 33.03 Christmas tree Sales

Christmas tree sales may be permitted in any noncommercial parcel or on church, school or other similar sites for a period not exceeding thirty-five (35) days, provided no activities are conducted within the public right-of-way and off-street parking is provided in accordance with the minimum parking setback. Approval of a Temporary Zoning Certificate must be obtained from the Zoning Inspector prior to conducting such temporary sales.

Section 33.04 Model Homes

A model home may be used as a temporary real estate sales office within any zoning district for the sale of residential dwelling units to be erected within the subdivision in which the model home is located, subject to the following requirements:

- A. A Temporary Zoning Certificate shall be obtained prior to establishing the temporary sales office. Sales offices shall not be established in a temporary structure or vehicle.
- B. Sales activities shall be limited to the sale of new residential dwelling units to be erected within the subdivision in which the model home is located. Rentals or

resale of lots and/or units within the subdivision shall not be permitted.

- C. All exterior lighting, except for security lighting, must be down-lighting, so that no light shall be cast onto adjoining residential properties. All off-street parking areas must be illuminated. All exterior lighting, except for security lighting, shall be extinguished at the closing time of the model home.
- D. All model homes shall provide off-street paved parking for the public. The number of required parking spaces shall be at least six (6) per model home. The driveway of the model home may be utilized for not more than two (2) parking spaces.
- E. Landscape drawing shall be required and show adequate landscaping and screening from adjoining residential lots, together with the clear marking of the boundaries of the model home lot. Trash receptacles shall be provided around the model home.
- F. The use of model homes within a residential subdivision shall terminate when building permits have been issued for ninety-five percent (95%) of the lots within such subdivision.

Section 33.05 Contractor's Offices

Temporary structures (other than portable storage units) such as a mobile office and temporary buildings of a nonresidential character may be used incidental to construction work on the premises or on adjacent public projects or during a period while the permanent dwelling is being constructed. The user of said structure shall obtain a Temporary Zoning Certificate for such temporary use, which permit shall be valid for six (6) months and may be renewed for additional six (6) month periods. Renewal of the permit shall be at the discretion of the Zoning Inspector on finding of reasonable progress toward completion of the permanent structure or project. The Zoning Inspector may require provisions for sanitary waste disposal, solid waste disposal and water supply, as he/she deems necessary. Said temporary structure shall be removed no later than ten (10) days after expiration of said permit.

Section 33.06 Portable Storage Units

- A. Portable Storage Units may be permitted as a temporary use in any zoning district only in conjunction with and not to exceed the times listed for the following activities:

1. Temporary use for construction sites as accessory to and in association with an ongoing construction project at such site for a period of up to one hundred twenty (120) total days in any three hundred sixty-five (365) consecutive day period or upon the completion of the project, whichever occurs sooner.
2. Temporary use when the occupant of the property on which the portable storage unit is located is relocating for a period not to exceed seven (7) consecutive days or for a period of fourteen (14) total days in any one hundred eighty (180) consecutive day period.
3. Temporary use to facilitate temporary activities not described in Section 430.08 1 or 2, above, for a period not to exceed seven (7) consecutive days or for a period of fourteen (14) total days in any one hundred eighty (180) consecutive day period.

B. Portable Storage Unit Criteria. Portable storage units shall be subject to the following requirements:

1. A portable storage unit shall not exceed one hundred sixty-nine (169) square feet in size and eight (8) feet in height.
2. Not more than one (1) portable storage unit shall be permitted on any property at any time.
3. No portable storage unit shall be located in a public right-of-way.
4. Portable storage units shall be located no closer to an adjacent property than the greatest of ten (10) feet or the required minimum side or rear yard setback for accessory buildings in the district in which the unit is located.
5. Portable storage units shall only be used for the storage of personal property and for no other purpose whatsoever, including, without limitation, sales of personal property.
6. The placement of portable storage units shall be in such manner as not to create a public nuisance.
7. A portable storage unit is not permitted as a permanent accessory storage structure regardless of the proposed location on a property.
8. A Temporary Zoning Certificate shall be obtained prior to the placement of a portable storage unit on a property. For the activities listed in Section 33.06 A 1 and 2, no more than two (2) Temporary

Certificates of Zoning Compliance may be issued for the same property during any three hundred sixty-five (365) consecutive day period.

Section 33.07 Definition

For purposes of this Resolution, a portable storage unit is defined as a non-permanent, non-habitable, self-contained unit designed for placement on and subsequent removal from a property which can be transported by vehicle and left on-site for the purpose of facilitating the storage of personal property.

Section 33.08 Additional Information

The Zoning Inspector shall have the authority to require any information deemed necessary or pertinent to the control of temporary uses in order to safeguard the public interest, and shall approve or disapprove the application based on the information submitted and the standards of this Zoning Resolution.

Scioto Township Zoning Resolution (Jan. 14, 2011) Text Amendments

Adopted by the Board of Township Trustees on June 15, 2011(Effective July 15, 2011):

Section 6.08

Within twenty (20) days after the public hearing required in Section 6.07 above, the Board of Township Trustees shall either adopt or deny the recommendation of the Zoning Commission, or may adopt some modification thereof. In the event the Board of Township Trustees denies or modifies the recommendation of the Zoning Commission, a majority vote of the Board of Township Trustees is required.

If a proposed amendment initiated by application is denied by the Board of Township Trustees, it may be resubmitted following the procedures as specified in Sections 6.02 through 6.07 above, at any time after one (1) year from the date action to deny was taken by the Board of Township Trustees.

Adopted by the Board of Township Trustees on November 16, 2011(Effective December 16, 2011):

29.05 Fences and/or Hedges in Particular Districts

"Fence" or "wall" means any structure composed of wood, metal, stone, brick or other material (including hedges or other plants) erected in such a manner and location so as to enclose, partially enclose or divide any premises or part of premises for the purpose of confinement, screening, partitioning, or decoration. Trellises or other structures for the purpose of supporting vines, flowers or other vegetation, when erected in such a position so as to enclose, partially enclose or divide any premises or any part of premises shall also be considered a fence. Notwithstanding the foregoing, a "fence" or "wall" does not include landscaping trees, planted along an adjacent property line, provided that the planting shall not obscure the vision of motorists.

No fence, hedge, or wall shall be erected on any lot in such a manner so as to obscure the vision of motorists approaching a street intersection. All fences and walls shall comply with section 29.05. However, only those fences or walls located within 20 feet of a property line shall obtain a zoning certificate prior to the installation or construction of such fence or wall. Applications for a zoning certificate for a fence or wall shall include a detailed drawing or photograph of the proposed fence and a site plan indicating its location.

The fence or wall shall not encroach on the right-of-way of any adjacent street, road or highway. Fences or walls shall be structurally sound, safe, and be properly maintained in good condition. Fences or walls shall be designed, constructed, and finished so the supporting members thereof shall face the property owner of the fence. Ground areas between the fence and the property line and between fences shall be kept properly maintained at all times.

A. The following additional provisions shall apply only to fences and walls in the R-1, R-2, R-3, PCRD, PURD and MHR Districts:

1. Fences located in a front or corner lot front yard shall not exceed four (4) feet in height. The fence shall be located at least forty feet (40') from the centerline of any such adjacent right-of-way;
2. The height of a fence located in a side or rear yard is restricted to 7 feet; and
3. No person shall erect or maintain any fence or wall charged with electrical current, nor shall any person erect or maintain any fence or wall having wire or metal prongs or spikes, or other cutting points or edges. This provision shall not prohibit ornamental wrought iron and similar decorative type fencing. This shall also not prohibit underground invisible fences installed for the purpose of confining pets to property.

B. The following additional provisions shall apply only to fences and walls in the GC, NC, SO, and SU Districts:

1. Fences located in a front or corner lot front yard shall not exceed four (4) feet in height. The fence shall be located at least forty feet (40') from the centerline of any such adjacent right-of-way and adequate sight distance is maintained;
and
2. The height of fences located in a side or rear yard is restricted to 12 feet.

Scioto Township Zoning Resolution (January 14, 2011)

Text Amendments

Section 14.05.04 Minimum Side Yard Width 6/3/2018

Section 21.017E PUD General 10/19/2019

Section 21.043.E. Residential Density 6/3/2018

Section 21.043.G Setback Requirements 6/3/2018

Section 21.043.H Lot Dimensions 6/3/2018

Section 21.043.K Sidewalks 6/3/2018

Section 21.043.L Streets 6/3/2018

Section 29.03.A Detached Accessory Structures 6/3/2018